

TROUBLESHOOTER



JOLLYFILL INLET VALVE INSTRUCTIONS

Telescopic Bottom / Fixed Bottom / Side inlet

240308_02
11/2020

PROBLEM	CAUSE	SOLUTIONS
THE CISTERN IS NOT FILLING	<ul style="list-style-type: none"> Turn on water supply The inlet valve is shut off and does not open 	<ul style="list-style-type: none"> Turn on water supply Check all moving components move up and down freely. If not unclip the rod from the float (photos 1 and 2). Reclip it in correct way (photos 3 and 4).
LEAK FROM THE FLUSHING INTERNAL VALVE OVERFLOW	<ul style="list-style-type: none"> The high level of the float basin is higher than the top level of the overflow 	<ul style="list-style-type: none"> Flush the cistern. Turn the water supply off. Unclip the adjustment rod from the float (photos 1 and 2). Push on the float in order to make it go down. Clip the adjustment rod on the float in the correct way (photos 3 and 4). Check that the water level is right (scheme 5).
THE FULL FLUSH OR THE HALF FLUSH IS NOT SUFFICIENT	<ul style="list-style-type: none"> The water height is too low in the tank 	<ul style="list-style-type: none"> Flush the cistern. Turn off water supply. Unclip the adjustment rod from the float (photos 1 and 2) Raise the level of the float basin on the body Re clip the adjustment rod on the float in the correct way (photos 3 and 4). Check the flush is sufficient. Unclip the red adjustment rod from the float (photos 1 and 2). Reclip it in correct way (photos 3 and 4). Put the filter restrictor in accordance with the instructions (Scheme 6). Wash the diaphragm in conformity with the instructions described on the back. Before turning water on, ensure that one cold water tap is open so that dirt and loose particles in the pipe work are flushed through the tap (Scheme 7). Wash the filter restrictor (photo 10) in conformity with the instructions described on the back. Wash the diaphragm (Scheme 7) in conformity with the instructions described on the back. Call after self service number (Helpline Number). Put the filter restrictor in accordance with the instructions (Scheme 6). Put the filter restrictor in accordance with the instructions (Scheme 6). Wash the diaphragm in conformity with the instructions described on the back (Scheme 7). Before turning water on, ensure that one cold water tap is open so that dirt and loose particles in the pipe work are flushed through the tap.
THE INLET VALVE DOES NOT SHUT OFF OR SHUTS OFF VERY SLOWLY (At the installation)	<ul style="list-style-type: none"> The float is completely outside the float basin. 	<ul style="list-style-type: none"> Unclip the red adjustment rod from the float (photos 1 and 2). Reclip it in correct way (photos 3 and 4). Put the filter restrictor in accordance with the instructions (Scheme 6). Wash the diaphragm in conformity with the instructions described on the back. Before turning water on, ensure that one cold water tap is open so that dirt and loose particles in the pipe work are flushed through the tap (Scheme 7). Wash the filter restrictor (photo 10) in conformity with the instructions described on the back. Wash the diaphragm (Scheme 7) in conformity with the instructions described on the back. Call after self service number (Helpline Number). Put the filter restrictor in accordance with the instructions (Scheme 6). Put the filter restrictor in accordance with the instructions (Scheme 6). Wash the diaphragm in conformity with the instructions described on the back (Scheme 7). Before turning water on, ensure that one cold water tap is open so that dirt and loose particles in the pipe work are flushed through the tap.
THE INLET VALVE DOES NOT SHUT OFF OR SHUTS OFF VERY SLOWLY (after a few months of using)	<ul style="list-style-type: none"> The diaphragm has some debris because the filter is missing. The diaphragm has some debris because the dirt and loose particles in the pipe work have not been flushed through the tap before having turned the water on (the filter has well been assembled on the valve). The filter restrictor has some debris. The diaphragm has some debris. The diaphragm is damaged. The flow restrictor has not been fitted in accordance with the instructions. The diaphragm has some debris because the filter restrictor is missing. The diaphragm has some debris because the dirt and loose particles in the pipe work have not been flushed through the tap before having turned water on (the filter has been assembled on the valve). 	<ul style="list-style-type: none"> Put the filter restrictor in accordance with the instructions (Scheme 6). Wash the diaphragm in conformity with the instructions described on the back (Scheme 7). Before turning water on, ensure that one cold water tap is open so that dirt and loose particles in the pipe work are flushed through the tap.
THE CISTERN IF FILLING VERY SLOWLY (at the installation)	<ul style="list-style-type: none"> The diaphragm has some debris The diaphragm is damaged 	<ul style="list-style-type: none"> Wash the diaphragm (Scheme 7) in conformity with the instructions described on the back. Call after self service number (Helpline number).
THE CISTERN IS NOT FILLING OR IS FILLING VERY SLOWLY (After a few months of using)	<ul style="list-style-type: none"> The diaphragm has some debris The diaphragm is damaged 	<ul style="list-style-type: none"> Wash the diaphragm (Scheme 7) in conformity with the instructions described on the back. Call after self service number (Helpline number).
THE CISTERN IS FILLING TOO QUICKLY	<ul style="list-style-type: none"> The filter restrictor has not been fitted in accordance the instructions 	<ul style="list-style-type: none"> Put the filter restrictor in accordance with the instructions (Scheme 6).
LEAK FROM THE BACK NUT	<ul style="list-style-type: none"> The back nut is not tight enough The rubber washer is missing on the inlet valve The rubber washer is damaged 	<ul style="list-style-type: none"> Re tighten the back nut (photo 8). Assemble the rubber washer on the valve (Scheme 9). Call after service number (Helpline number).

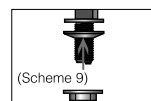
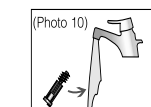
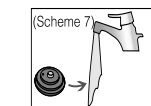
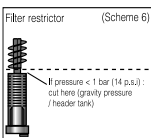
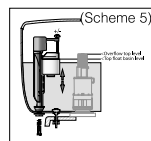
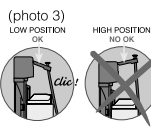



JOLLYFILL TELESCOPIC BOTTOM ENTRY INLET VALVE

A : PRE-INSTALLATION

- Turn off water supply to cistern and remove cistern lid.
- Flush the cistern and remove any loose dirt from inside the tank.
- Disconnect and remove the existing inlet valve.

B : INSTALLATION

- Insert correct filter restrictor into threaded tail.

- Fit the filling valve. Ensure that the valve does not obstruct the flush mechanism. Do not overtighten the back nut. 
- Important for new installations : before turning water on, ensure that one cold water tap is open so that dirt and loose particles in the pipe work are flushed through the tap (we also recommend to flush through the water supply pipe to the cistern before connection is made). 
- Connect water supply.
- Turn on water supply. Allow the cistern to fill,
- Adjust the water level.

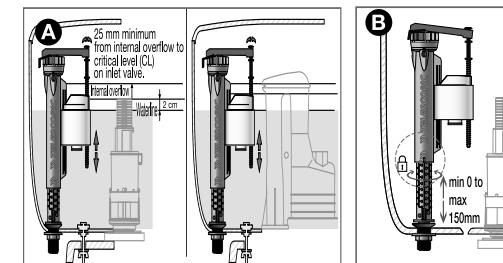

B

If the water level is not correct, turn off water supply. Adjust the water level by : Turning slowly right or left to open. Pulling up the body of the telescopic part, (see pic B). Turning slowly right or left to lock. Turn on water supply.

C

You can precisely adjust the float basin with the red rod. Unclip the red rod Adjust the float basin Clip the red rod.

TROUBLE SHOOTING MAINTENANCE FOR JOLLYFILL SIDE AND BOTTOM ENTRY VALVES

Turn off water supply before any maintenance is carried out. 

- BOTTOM ENTRY**
 - Remove and wash the diaphragm and reassemble in reverse order.
 - Remove and wash the filter restrictor and reassemble in reverse order.
- SIDE ENTRY**
 - Remove and wash the diaphragm and reassemble in reverse order.
 - Remove and wash the filter restrictor and reassemble in reverse order.



www.wirquin.co.uk

Wirquin Ltd - Unit 3, Alpha Court, Capitol Park,
Thorne, DN8 5TZ - UK
T: +44(0) 333 222 4488 | Email: sales@wirquin.co.uk

wirquin

JOLLYFILL SIDE ENTRY INLET VALVE



A : PRE-INSTALLATION

- 1 Turn off water supply to cistern and remove cistern lid.
- 2 Flush the cistern and remove any loose dirt from inside the tank.
- 3 Disconnect and remove the existing inlet valve.

B : INSTALLATION

- 1 Insert correct filter restrictor into threaded tail.

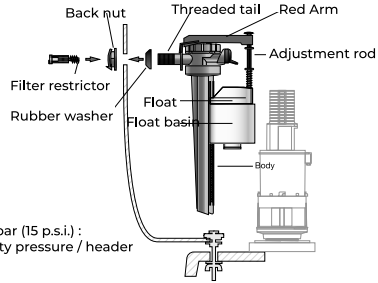

If pressure < 1 bar (15 p.s.i.) : cut here (gravity pressure / header tank)

- 2 Fit the filling valve. Ensure that the valve does not obstruct the flush mechanism. Do not overtighten the back nut.

If the filling valve touches the flush mechanism go to C: Rotation of Filling Valve.

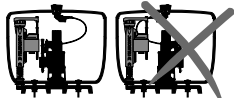

- 3 Important for new buildings/installations : before turning water on, ensure that one cold water tap is open so that dirt and loose particles in the pipe work are flushed through the tap (we also recommend to flush through the water supply pipe to the cistern).

- 4 To adjust the water level, unclip the adjustment rod from the float.

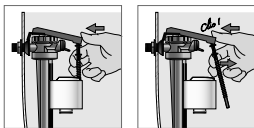

- 5 Adjust the float basin. Check that the top of the float basin is set to waterline (Y) and internal overflow is 20mm above the water line.

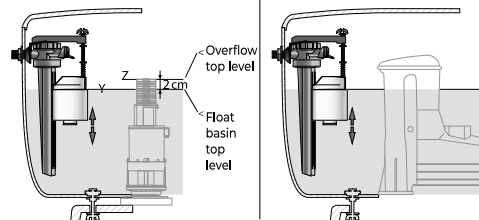

- 6 Clip the adjustment rod on the float: check that the red arm is in low position before clipping the rod.

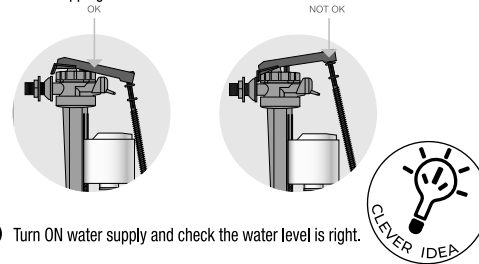

- 7 Turn ON water supply and check the water level is right.

C : ROTATION OF FILLING VALVE

This allows the Jollyfill to be fitted inside the most compact cisterns.

- 1 Unscrew the grey nut below the red lever by 1 turn.

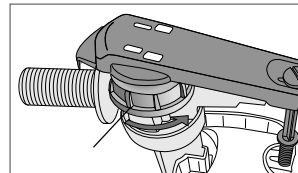

- 2 While holding the red lever, rotate the filling valve into the appropriate position.

The float basin can touch the cistern walls.

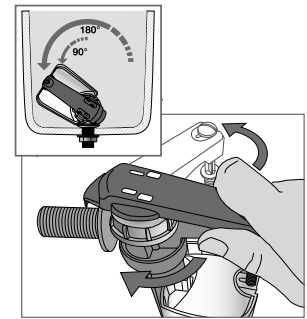

Make sure the float moves freely after this adjustment has been carried out, or the inlet valve will not shut off or will be in shut off position.

JOLLYFILL 9.5" FIXED BOTTOM ENTRY INLET VALVE



A : PRE-INSTALLATION

- 1 Turn off water supply to cistern and remove cistern lid.
- 2 Flush the cistern and remove any loose dirt from inside the tank.
- 3 Disconnect and remove the existing inlet valve.

B : INSTALLATION

- 1 Insert correct filter restrictor into threaded tail.

If pressure < 1 bar (14 p.s.i.) : cut here (gravity pressure/header tank)

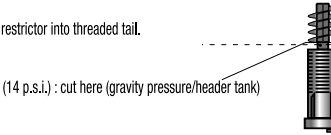

- 2 Fit the filling valve. Ensure that the valve does not obstruct the flush mechanism. Do not overtighten the back nut.

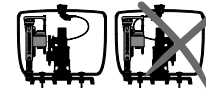

- 3 Important for new build / installations : before turning water on, ensure that one cold water tap is open so that dirt and loose particles in the pipe work are flushed through the tap (we also recommend to flush through the water supply pipe to the cistern before connection is made).

- 4 Connect water supply.

- 5 Turn on water supply. Allow the cistern to fill.

Adjust the water level :

A - Turn off the water supply and flush the cistern

B - Unclip the adjustment rod from the float 5B

C - Adjust the height of the float basin on the body 5C

D - Clip the adjustment rod on the float 5D : check that the red arm is in low position before clipping the rod and the float is positioned inside the float basin.

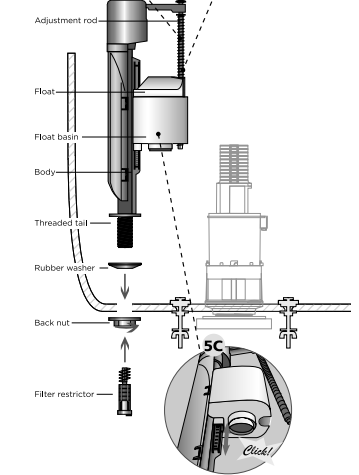
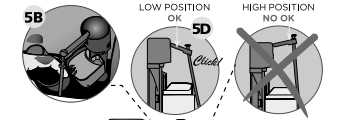

E - Check the water level is right

F - Check that the high level of the float basin is lower than the top level of the flushing valve overflow.

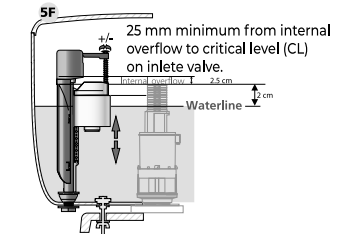

TROUBLESHOOTER

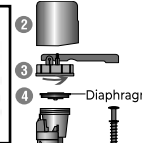

- 1 Turn off water
- 2 Remove cover
- 3 Unscrew retaining nut
- 4 Remove diaphragm
- 5 Wash diaphragm and assemble in reverse order
- 6 Screw retaining nut and tighten. Ensure it is correctly positioned.
- 7 Assemble cover on nut and ensure it is clipped fully on nut
- 8 Turn on water supply and ensure the valve operates correctly

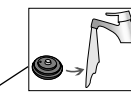

- 9 Turn off water
- 10 Disconnect the water supply
- 11 Remove filter restrictor see image 'A'
- 12 Wash filter restrictor
- 13 Assemble filter restrictor into threaded tail
- 14 Connect water supply
- 15 Turn on water supply

