

ATTENTION!
REMOVE FILM PRIOR TO FITTING

- Please note prior to fitting your bath carefully remove all the packaging and film from the bath and examine the bath for damage and suitability of colour match.
- Check the panel fit and match prior to installation.

No Claims for the above will be accepted once the bath is fitted.

List of Parts Supplied for:

Curve bath	1698 x 800	p.2
Curve panel	1704 x 535	p.3

Item No.	Quantity	Description	Checked
1	2	500mm Channels	
2	2	350mm Jack Legs	
3	4	120mm Allthreads	
4	2	Wall Fixing Brackets	
5	4	M12 x 65mm Plastic Foot	
6	2	M10 x 200 Metal Feet	
7	1	M10 x 90mm Centre Foot	
8	1	Centre Foot Bracket	
9	4	M10 Nuts	
10	12	M12 Nuts	
11	36	9mm (5/8) Self Tapping Screws	
12	10	Panel Clips	
13	1	Fitting Instructions	

Please Note:

- Baths should be set at supplied panel height (535mm).
- The 18mm baseboard is encapsulated on all baths listed above (i.e. under the GRP reinforcement).
- Half of the panel clips supplied should be secured (if possible) to the floor.

Curve Bath
1698 x 800mm

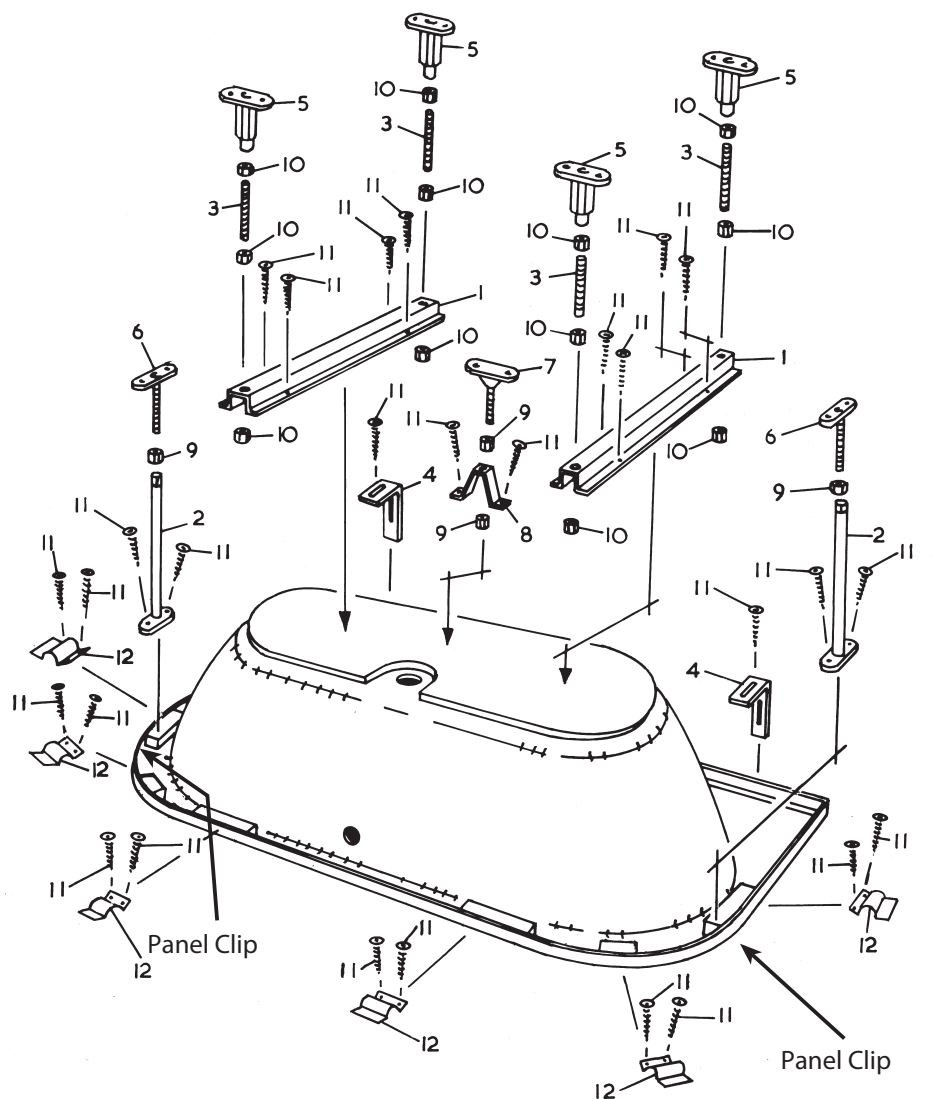

Curve Panel Prior to Fitting

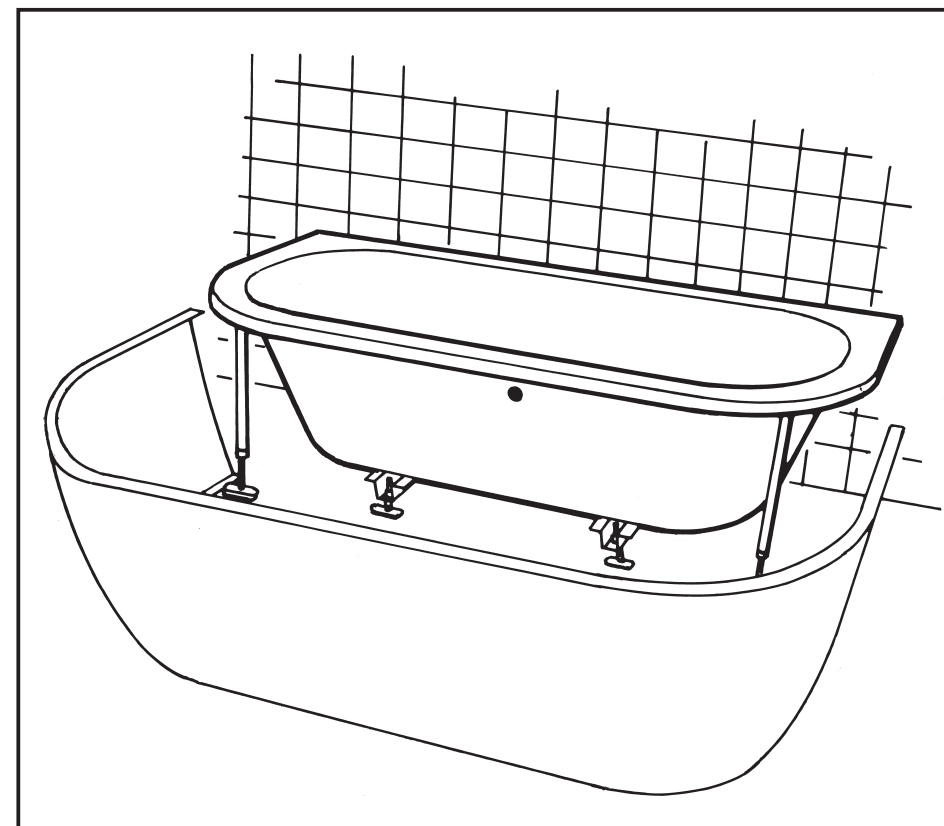

Present front panel to the bath as shown in drawing. Position the panel and locate the returned edge into the panel clips that have been fixed prior to installation. Scribe a line on the wall and floor following the contour of the panel, remove the panel from the bath and scribe a line 3mm in front from the first scribed line. On the second scribed line fasten a batten on the wall, allowing room for the returned edge of the panel top and bottom. Secure four panel clips to the floor, positioned at equal distances from the centre of the curve. Present the panel to the bath engaging the top and bottom return of the panel between the roll of the bath and the panel clips. Secure the panel to the wall battens using the appropriate fixings (not supplied).