

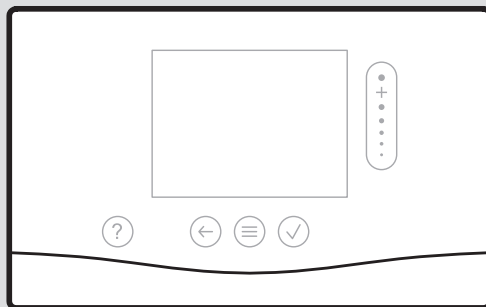

# sensoHOME

VRT 380f/2





Operating and installation  
instructions



en	<b>Operating and installation instructions .....</b>	<b>3</b>
----	--	----------

# Operating and installation instructions

## Contents

<b>1</b>	<b>Safety</b> .....	<b>4</b>	<b>5</b>	<b>Fault and maintenance messages</b> .....	<b>19</b>
1.1	Intended use .....	4	5.1	Fault message .....	19
1.2	General safety information.....	4	5.2	Maintenance message.....	19
1.3	 -- Safety/regulations .....	5	5.3	Changing the batteries.....	19
<b>2</b>	<b>Product description</b> .....	<b>6</b>	<b>6</b>	<b>Information about the product</b> .....	<b>21</b>
2.1	Which nomenclature is used?.....	6	6.1	Observing and storing other applicable documents .....	21
2.2	What is the effect of the frost protection function? .....	6	6.2	Validity of the instructions .....	21
2.3	What do the following temperatures mean?.....	6	6.3	Data plate .....	21
2.4	What is a zone? .....	6	6.4	Serial number .....	21
2.5	What is the circulation?.....	6	6.5	CE marking .....	21
2.6	What is meant by "time period"? ....	6	6.6	Guarantee and customer service .....	21
2.7	Preventing malfunctions .....	7	6.7	Recycling and disposal .....	21
2.8	Setting the heat curve.....	7	6.8	Product data in accordance with EU Ordinance no. 811/2013, 812/2013.....	22
2.9	Display, control elements and symbols.....	7	6.9	Technical data .....	22
2.10	 -- Using the control .....	9	<b>Appendix</b> .....	<b>23</b>	
2.11	Operating and display functions ....	9	<b>A</b>	<b>Troubleshooting, maintenance message</b> .....	<b>23</b>
<b>3</b>	 -- <b>Electrical installation, set-up</b> .....	<b>16</b>	A.1	Troubleshooting .....	23
3.1	Checking the scope of delivery ....	16	A.2	Maintenance messages.....	23
3.2	Selecting the lines.....	16	<b>B</b>	 -- <b>Troubleshooting, maintenance message</b> .....	<b>24</b>
3.3	Polarity.....	16	B.1	Troubleshooting .....	24
3.4	Installing the radio receiver unit .....	16	B.2	Troubleshooting .....	24
3.5	Installing the control.....	17	B.3	Maintenance messages.....	24
<b>4</b>	 -- <b>Start-up</b> .....	<b>19</b>	<b>Index</b> .....	<b>25</b>	
4.1	Prerequisites for starting up.....	19			
4.2	Running the installation assistants.....	19			
4.3	Changing the settings later .....	19			

# 1 Safety

## 1.1 Intended use

In the event of inappropriate or improper use, damage to the product and other property may arise.

The product is intended for using an eBUS interface to control a heating installation with heat generators from the same manufacturer.

The control controls based on the installed system:

- Heating
- Domestic hot water generation
- Circulation

Intended use includes the following:

- observance of accompanying operating, installation and maintenance instructions for the product and any other system components
- installing and setting up the product in accordance with the product and system approval
- compliance with all inspection and maintenance conditions listed in the instructions.

Intended use also covers installation in accordance with the IP code.

This product can be used by children aged from 8 years

and above and persons with reduced physical, sensory or mental capabilities or lack of experience and knowledge if they have been given supervision or instruction concerning use of the product in a safe way and understand the hazards involved. Children must not play with the product. Cleaning and user maintenance work must not be carried out by children unless they are supervised.

Any other use that is not specified in these instructions, or use beyond that specified in this document, shall be considered improper use. Any direct commercial or industrial use is also deemed to be improper.

### **Caution.**

Improper use of any kind is prohibited.

## 1.2 General safety information

### 1.2.1 Risk caused by inadequate qualifications

The following work must only be carried out by competent persons who are sufficiently qualified to do so:

- Set-up
- Dismantling
- Installation
- Start-up

- Decommissioning
- Troubleshooting and fault elimination
- ▶ Proceed in accordance with current technology.

Work and functions that must only be carried out or set by the competent person are marked by the  symbol.

### **1.2.2 Danger caused by improper operation**

Improper operation may present a danger to you and others, and cause material damage.

- ▶ Carefully read the enclosed instructions and all other applicable documents, particularly the "Safety" section and the warnings.
- ▶ As the end user, you should only carry out those activities for which these instructions provide instructions and that are not marked with the  symbol.

### **1.2.3 Batteries**

- ▶ Note the battery type, as described in these instructions; see section "Data plate".
- ▶ Remove and insert batteries as described in these instructions; see section "Changing the batteries".
- ▶ Do not recharge non-rechargeable batteries.

- ▶ Remove rechargeable batteries from the product before charging them.
- ▶ Do not combine batteries with other battery types.
- ▶ Do not combine new and used batteries.
- ▶ Insert the batteries, making sure that the poles are the right way round.
- ▶ Remove the dead batteries from the product and dispose of them correctly.
- ▶ Remove the batteries if you intend to store the product and not use it for an extended period and/or to scrap it.
- ▶ Do not short-circuit the connection contacts in the product's battery compartment.

## **1.3 -- Safety/regulations**

### **1.3.1 Risk of material damage caused by frost**

- ▶ Do not install the product in rooms prone to frost.

### **1.3.2 Risk of material damage caused by using an unsuitable tool**

- ▶ Use the correct tool.

### **1.3.3 Regulations (directives, laws, standards)**

- ▶ Observe the national regulations, standards, directives, ordinances and laws.

## 2 Product description

### 2.1 Which nomenclature is used?

- Control: Instead of **VRT 380f/2**

### 2.2 What is the effect of the frost protection function?

The frost protection function protects the heating installation and flat from frost damage.

At outdoor temperatures

- Below 4 °C for longer than four hours, the control switches the heat generator on and regulates the target room temperature to at least 5 °C.
- Above 4 °C, the control does not switch the heat generator on, but it monitors the outdoor temperature.

### 2.3 What do the following temperatures mean?

**Desired temp.** is the temperature to which you want to heat the living rooms.

**Set-back temp.** is the level below which the temperature in the living rooms does not fall when outside of the time periods.

**Flow temp.** is the temperature at which the heating water leaves the heat generator.

**Domestic hot water temperature** is the temperature to which the domestic hot water cylinder is to be heated.

### 2.4 What is a zone?

A building can be divided into multiple areas, which are known as zones. A different requirement can be placed on the heating installation in each zone.

Examples for dividing into zones:

- Underfloor heating (zone 1) and a radiator system (zone 2) are available in one building.
- A building is made up of several self-contained residential units. Each residential unit has its own zone.

### 2.5 What is the circulation?

An additional water pipe is connected to the domestic hot water pipe and forms a circuit with the domestic hot water cylinder. A circulation pump facilitates the continuous circulation of domestic hot water through the pipework system which means that hot water is immediately available, even at more distant draw-off points.

### 2.6 What is meant by "time period"?

Example of heating mode in the mode: Time-controlled

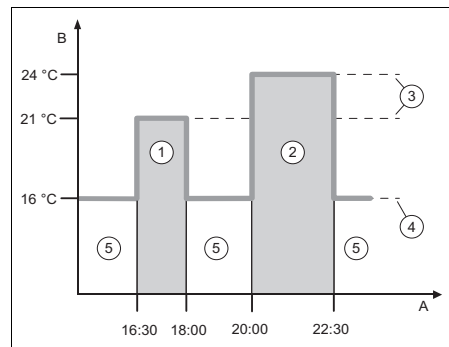

A	Time	3	Desired temperature
B	Temperature	4	Set-back temperature
1	Time period 1	5	Outside of the time periods
2	Time period 2		

You can divide a day up into several time periods (1) and (2). Each time period can comprise an individual start time and end time. The time periods must not overlap. You can assign a different desired temperature (3) to each time period.

Example:

16:30 to 18:00; 21 °C

20:00 to 22:30; 24 °C

The control regulates the living rooms to the desired temperature within the time periods. In the times outside of the time periods (5), the control regulates the living rooms to the lower set-back temperature (4) that is set.

## 2.7 Preventing malfunctions

- ▶ Do not cover the control with furniture, curtains or other objects.
- ▶ If the control is installed in the living room, open all of the thermostatic radiator valves in this room fully.

## 2.8 Setting the heat curve

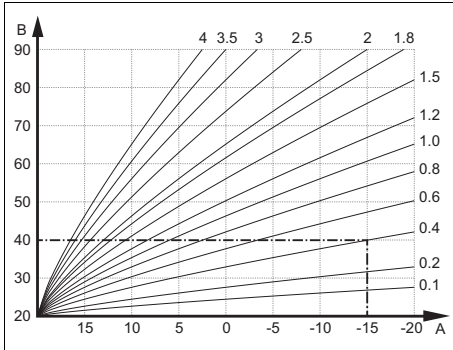

A Outside temperature °C      B Target flow temperature °C

The figure shows the possible heat curves of 0.1 to 4.0 for a target room temperature of 20 °C. If, for example, heat curve 0.4 is selected, a flow temperature of 40 °C is maintained at an outdoor temperature of -15 °C.

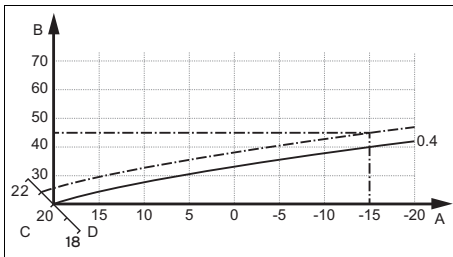

A Outdoor temperature °C      C Target room temperature °C  
 B Target flow temperature °C      D Axis a

If the heat curve 0.4 is selected and 21 °C is specified for the target room temperature, the heat curve is then translated, as shown in the figure. The heat curve is displaced according to the value of the target room temperature along axis a which

is angled at 45°. At an outdoor temperature of -15 °C, the control system provides a flow temperature of 45 °C.

## 2.9 Display, control elements and symbols

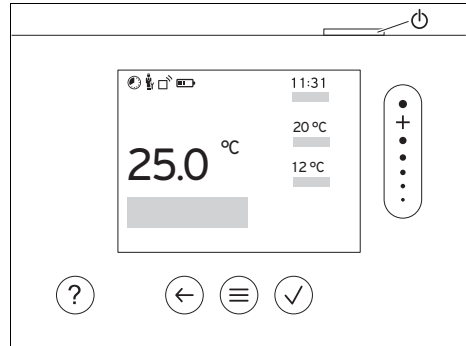

### 2.9.1 Control elements

- Calling up the menu
- Back to the main menu
- Confirming a selection/change
- Saving set values
- One level back
- Cancelling input
- Navigating through the menu structure
- Reducing or increasing the set value
- Navigating to individual numbers/letters
- Calling up help
- Calling up the time programme assistant
- Switching on the display
- Switching off the display

The control element is located on the upper side of the control.

Active control elements light up green.

Press once: You access the basic display.

Press twice: You access the menu.

## 2.9.2 Symbols



Battery state of charge

---



Signal strength

---



Time-controlled heating active

---



Maintenance required

---



Fault in the heating installation

---



Contact the competent person

---

## 2.10 -- Using the control

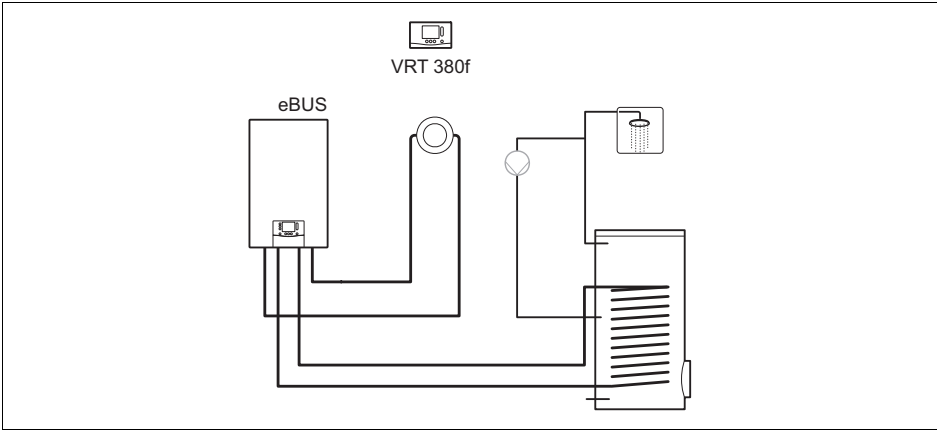

The control is installed in simple systems with direct heating circuits.



### Note

After connecting an outdoor sensor, the control operates based on the weather.

## 2.11 Operating and display functions



### Note

The functions described in this section are not available for all system configurations.

The product has two adjustment and display levels.

The end user level contains information and setting options that you require as the end user.



-- The installer level is reserved for the competent person. It is protected by a code. Only competent persons may change any settings in the installer level.

To call up the menu, press  twice.

### 2.11.1 CONTROL menu item

MENU → CONTROL		
→ Zone		
→ Mode:	→ Manual	→ Desired temperature: °C
	Uninterrupted retention of the desired temperature	
	→ Time-contr.	→ Weekly planner
	→ Set-back temperature: °C	

MENU → CONTROL																
→ <b>Mode:</b>	<p><b>Weekly planner:</b> Up to 12 time periods and desired temperatures can be set per day The competent person sets how the heating installation behaves outside of the time period in the <b>Set-back mode:</b> function. In <b>Set-back mode:</b> means:</p> <ul style="list-style-type: none"> <li>– <b>Eco:</b> The heating is switched off outside of the time periods. Frost protection is activated.</li> <li>– <b>Normal:</b> The set-back temperature applies outside of the time periods.</li> </ul> <p><b>Desired temperature: °C:</b> Applies within the time periods Factory setting: <b>Set-back temperature: °C 15 °C</b></p> <p>→ <b>Off</b></p> <p>Heating is switched off, domestic hot water continues to be available, frost protection is activated</p>															
→ <b>Name of zone</b>	Changing the name <b>Zone 1</b> , which was set at the factory															
→ <b>Absence</b>	<p>→ <b>All:</b> Applies only to any zones within the specified time period</p> <p>→ <b>Zone:</b> Applies for the selected zone in the specified time period</p> <p>During this time, heating mode runs at the defined set-back temperature. Domestic hot water mode and circulation are switched off. Factory setting: <b>Set-back temperature: °C 15 °C</b></p>															
→ <b>DHW</b>																
→ <b>Mode:</b>	<table border="1" style="width: 100%; border-collapse: collapse;"> <tr> <td style="width: 33%; text-align: center;">→ <b>Manual</b></td> <td style="width: 33%; text-align: center;">→ <b>DHW temperature: °C</b></td> <td style="width: 34%;"></td> </tr> <tr> <td colspan="3">Uninterrupted retention of the domestic hot water temperature</td> </tr> <tr> <td style="text-align: center;">→ <b>Time-contr.</b></td> <td style="text-align: center;">→ <b>Domestic hot water weekly planner</b></td> <td></td> </tr> <tr> <td></td> <td style="text-align: center;">→ <b>DHW temperature: °C</b></td> <td></td> </tr> <tr> <td></td> <td style="text-align: center;">→ <b>Circulation weekly planner</b></td> <td></td> </tr> </table> <p><b>Domestic hot water weekly planner:</b> Up to three time periods can be set per day <b>DHW temperature: °C:</b> Applies within the time periods Domestic hot water mode is switched off outside of the time periods <b>Circulation weekly planner:</b> Up to three time periods can be set per day The circulation pump pumps hot water to the draw-off points within the time periods Outside of the time periods, the circulation pump is switched off</p> <p>→ <b>Off</b></p> <p>Domestic hot water mode is switched off</p>	→ <b>Manual</b>	→ <b>DHW temperature: °C</b>		Uninterrupted retention of the domestic hot water temperature			→ <b>Time-contr.</b>	→ <b>Domestic hot water weekly planner</b>			→ <b>DHW temperature: °C</b>			→ <b>Circulation weekly planner</b>	
→ <b>Manual</b>	→ <b>DHW temperature: °C</b>															
Uninterrupted retention of the domestic hot water temperature																
→ <b>Time-contr.</b>	→ <b>Domestic hot water weekly planner</b>															
	→ <b>DHW temperature: °C</b>															
	→ <b>Circulation weekly planner</b>															
→ <b>Hot water boost</b>	Heating up the water in the cylinder once															
→ <b>Ventilation boost</b>	Heating mode is switched off for 30 minutes.															
→ <b>Time programme assistant</b>	<p>Programming of the desired temperature for Monday–Friday and Saturday–Sunday; the programming applies for the time-controlled <b>Heating, DHW and Circulation</b> functions. Overwrites the weekly planner for the <b>Heating, DHW and Circulation</b> functions.</p>															
→ <b>Installation off</b>	Installation is switched off. Frost protection remains active.															

## 2.11.2 INFORMATION menu item

MENU → INFORMATION	
→ <b>Current temperatures</b>	
→ <b>Zone</b>	
→ <b>DHW temperature</b>	
→ <b>Water pressure: bar</b>	
→ <b>Energy data</b>	
→ <b>Power consumption</b>	→ <b>Heating</b>
	→ <b>DHW</b>
	→ <b>Installation</b>
→ <b>Fuel consumption</b>	→ <b>Heating</b>
	→ <b>DHW</b>
	→ <b>Installation</b>
<p>Energy consumption display</p> <p>In the display and in the app that can also be used, the control displays values for the energy consumption.</p> <p>The control displays an estimation of the values for the installation. Among other things, the values are influenced by the following:</p> <ul style="list-style-type: none"> <li>– The installation/design of the heating installation</li> <li>– User behaviour</li> <li>– Seasonal environmental conditions</li> <li>– Tolerances and components</li> </ul> <p>External components, such as external heating pumps or valves, and other consumers and appliances in the household are still not taken into consideration.</p> <p>The deviations between the energy consumption that is displayed and the actual energy consumption may be significant.</p> <p>The specifications for the energy consumption are not suitable to be used to create or compare energy billing.</p> <p>The following can be read: <b>Current month, Last month, Current year, Last year, Total</b></p>	
→ <b>Burner status:</b>	
→ <b>Control elements</b>	Explanation of the control elements
→ <b>Menu introduction</b>	Explanation of the menu structure
→ <b>Competent person contact info</b>	
→ <b>Serial number</b>	

## 2.11.3 -- SETTINGS menu item

MENU → SETTINGS	
 → <b>Installer level</b>	
→ <b>Enter access code</b>	Access to the installer level, factory setting: 00
→ <b>Competent person contact info</b>	Entering contact details
→ <b>Service date:</b>	Enter the next service date for a connected component, e.g. heat generator
→ <b>Fault history</b>	Faults are listed in chronological order

MENU → SETTINGS	
→ <b>Installation configuration</b>	Functions (→ <b>Installation configuration</b> menu item)
→ <b>Screed drying</b>	Activate the <b>Screed drying profile</b> function for freshly laid screed in accordance with the construction regulations. The control regulates the flow temperature independently of the outdoor temperature. Setting screed drying (→ <b>Installation configuration</b> menu item)
→ <b>Change code</b>	
→ <b>Language, time, display</b>	
→ <b>Language:</b>	
→ <b>Date:</b>	After the power is switched off, the date is retained for approx. 30 minutes.
→ <b>Time:</b>	After the power is switched off, the time is retained for approx. 30 minutes.
→ <b>Display brightness:</b>	
→ <b>Daylight saving time:</b>	→ <b>Automatic</b>
	→ <b>Manual</b>
For outdoor temperature sensors with DCF77 receivers, the <b>Daylight saving time:</b> function is not used. The conversion to summer/winter time takes place via the DCF77 signal. The change takes place:	
<ul style="list-style-type: none"> <li>– On the last weekend in March at 02:00 (daylight saving time)</li> <li>– On the last weekend in October at 03:00 (standard time)</li> </ul>	
→ <b>Offset</b>	
→ <b>Room temperature: K</b>	Comparison of the temperature difference between the measured value in the control and the value for a reference thermometer in the living room.
→ <b>Outdoor temperature: K</b>	Comparison of the temperature difference between the measured value in the outdoor temperature sensor and the value for a reference thermometer in the living room.
→ <b>Factory settings</b>	The control resets all of the settings to the factory settings and calls up the installation assistant. Only the competent person can call up the installation assistant.

## 2.11.4 -- Installation configuration menu item

MENU → SETTINGS → Installer level → Installation configuration	
→ <b>Installation</b>	
→ <b>Water pressure: bar</b>	
→ <b>eBUS components</b>	List of eBUS components and their software versions
→ <b>Adaptive heat curve:</b>	Automatic fine adjustment of the heat curve. Prerequisite: <ul style="list-style-type: none"> <li>– The suitable heat curve for the building is set in the <b>Heat curve:</b> function.</li> <li>– The correct zone is assigned to the control in the <b>Zone assignment:</b> function.</li> <li>– <b>Expanded</b> is selected in the <b>Room temp. mod.:</b> function.</li> </ul>

**MENU → SETTINGS → Installer level → Installation configuration**

→ <b>Control:</b>	<b>R.temp. contr</b>	It is controlled via the room temperature.
	<b>Weath.-comp.</b>	It is controlled via the outdoor temperature as soon as an outdoor temperature sensor is connected.
→ <b>OT constant heating: °C</b>	<p>If the outdoor temperature falls below the set temperature value, the <b>Heat curve</b>: is used to regulate to a room temperature of 20 °C outside of the time periods.</p> <p>OT ≤ set temperature value: No night set-back or total shut-down</p> <p>Factory setting: <b>Off</b></p>	
→ <b>Desired preheating temp.:</b>	<p>This is where you can select the desired pre-heating time temperature in order to activate the heating before the heating programme first starts. The aim is to reach the room temperature at the desired time. The system automatically calculates the required prerun time (max. 4 hrs) based on prior experience, the current room temperature and the time remaining until the programme changes.</p> <p>Factory setting: <b>Off</b></p>	
→ <b>Heat generator 1</b>		
→ <b>Status:</b>		
→ <b>Current flow temperature: °C</b>		
→ <b>Circuit 1</b>		
→ <b>Status:</b>		
→ <b>Target flow temperature: °C</b>		
→ <b>OT switch-off threshold: °C</b>	Enter the upper limit for the outdoor temperature. If the outdoor temperature rises above the set value, the control deactivates heating mode.	
→ <b>Heat curve:</b>	The heat curve (→ section "Product description") is the dependence of the flow temperature on the outdoor temperature for the desired temperature (target room temperature).	
→ <b>Min. target flow temperature: °C</b>	Enter the lower limit for the target flow temperature. The control compares the set value with the calculated target flow temperature, and regulates to the larger of these values.	
→ <b>Max. target flow temperature: °C</b>	Enter the upper limit for the target flow temperature. The control compares the set value with the calculated target flow temperature, and regulates to the smaller of these values.	
→ <b>Set-back mode:</b>		

**MENU → SETTINGS → Installer level → Installation configuration**

	<p>→ <b>Eco</b></p>	<p>The heating function is switched off and the frost protection function is activated.          At outdoor temperatures that are below 4 °C for longer than four hours, the control switches the heat generator on and regulates to the <b>Set-back temperature: °C</b>. At an outdoor temperature above 4 °C, the control switches the heat generator off. The monitoring of the outdoor temperature remains active.          Heating circuit behaviour outside of the time periods. Prerequisite:</p> <ul style="list-style-type: none"> <li>– <b>Time-contr.</b> is activated in the <b>Heating → Mode:</b> function.</li> <li>– <b>Active</b> or <b>Inactive</b> is activated in the <b>Room temp. mod.:</b> function.</li> </ul> <p>If <b>Expanded</b> is activated in the <b>Room temp. mod.:</b>, the control regulates to the target room temperature 5 °C independently of the outdoor temperature.</p>
	<p>→ <b>Normal</b></p>	<p>The heating function is switched on. The control regulates to the <b>Set-back temperature: °C</b>.          Prerequisite:</p> <ul style="list-style-type: none"> <li>– <b>Time-contr.</b> is activated in the <b>Heating → Mode:</b> function.</li> </ul>
<p>The behaviour can be adjusted separately for each heating circuit.</p>		
<p>→ <b>Room temp. mod.:</b></p>		
	<p>→ <b>Inactive</b></p>	
	<p>→ <b>Active</b></p>	<p>Adjusting the flow temperature based on the current room temperature.</p>
	<p>→ <b>Expanded</b></p>	<p>Adjusting the flow temperature based on the current room temperature. The control also activates/deactivates the zone.</p> <ul style="list-style-type: none"> <li>– The zone is deactivated: Current room temperature + 2/16 K &gt; set room temperature</li> <li>– Zone is activated: Current room temperature &lt; set room temperature - 3/16 K</li> </ul>
<p>The installed temperature sensor measures the current room temperature. The control calculates a new target room temperature that is used to adjust the flow temperature.</p> <ul style="list-style-type: none"> <li>– Difference = Set target room temperature - current room temperature</li> <li>– New target room temperature = Set target room temperature + difference</li> </ul> <p>Prerequisite: The control is assigned to the zone in which the control is installed in the <b>Zone assignment:</b> function.</p> <p>The <b>Room temp. mod.:</b> function is ineffective if <b>No assignmt</b> is activated in the <b>Zone assignment:</b> function.</p>		
<p>→ <b>Zone</b></p>		

**MENU → SETTINGS → Installer level → Installation configuration**

→ <b>Zone activated:</b>	Deactivate zones that are not required. All existing zones appear in the display.
→ <b>Zone assignment:</b>	Assign the control to the selected zone. The control must be installed in the selected zone. The control system also uses the room temperature sensor for the assigned unit. If no zone has been assigned to the control, the <b>Room temp. mod.:</b> function is ineffective.
→ <b>Zone valve status:</b>	
→ <b>DHW</b>	
→ <b>Cylinder:</b>	If there is an existing domestic hot water cylinder, the <b>Active</b> setting must be selected.
→ <b>Target flow temperature: °C</b>	
→ <b>Circulation pump:</b>	
→ <b>Anti-legio. day:</b>	Define the days on which you want the anti-legionella function to run. On these days, the water temperature is increased to above 60 °C. The circulation pump is activated. The function ends after 120 minutes at the latest. If the <b>Absence</b> function is activated, the anti-legionella function is not carried out. As soon as the <b>Absence</b> function ends, the anti-legionella function is carried out.
→ <b>Anti-legio. time:</b>	Define the time at which you want the anti-legionella function to run.
→ <b>Radio link</b>	
→ <b>Sys. control reception strength:</b>	Read the reception strength between the radio receiver unit and outdoor temperature sensor. <ul style="list-style-type: none"><li>– 4: The radio link is within the acceptable range. If the reception strength is &lt; 4, the radio link is not stable.</li><li>– 10: The radio link is highly stable.</li></ul>
→ <b>OT sensor reception strength:</b>	Read the reception strength between the radio receiver unit and outdoor temperature sensor. <ul style="list-style-type: none"><li>– 4: The radio link is within the acceptable range. If the reception strength is &lt; 4, the radio link is not stable.</li><li>– 10: The radio link is highly stable.</li></ul>
→ <b>Screed drying profile</b>	Setting target flow temperature per day in accordance with the construction regulations

### 3 -- Electrical installation, set-up

Obstacles weaken the reception strength between the radio receiver unit and the control or outdoor temperature sensor.

Only qualified electricians may carry out the electrical installation.

The heating installation must be decommissioned before work is carried out on it.

#### 3.1 Checking the scope of delivery

Quantity	Contents
1	Control
1	Radio receiver unit
1	Fixing material (2 screws and 2 wall plugs)
4	Batteries, LR06
1	Documentation

- ▶ Check that the scope of delivery is complete and intact.

#### 3.2 Selecting the lines

##### Line cross-section

eBUS line (fine-wire, flexible, made of copper)	0.75 ... 1.5 mm <sup>2</sup>
eBUS line (single-wire, made of copper)	1.0 ... 1.5 mm <sup>2</sup>
Sensor cable (fine-wire, flexible, made of copper)	0.75 ... 1.5 mm <sup>2</sup>
Sensor cable (single-wire, made of copper)	1.0 ... 1.5 mm <sup>2</sup>

##### Cable length

Bus lines	≤ 125 m
Sensor cable	≤ 50 m

#### 3.3 Polarity

When connecting the eBUS line, there is no need to pay attention to the polarity. If the connection cables are switched over, communication will not be adversely affected.

#### 3.4 Installing the radio receiver unit

The radio receiver unit can be installed on a heat generator.

When installing the radio receiver unit on a heat generator, the radio receiver unit can also be wall-mounted outside of wet environments in order to improve the reception strength and it can be connected using an extension cable.

##### 3.4.1 Installing the radio receiver unit and connecting to the heat generator

**Condition:** The heat generator has an option to connect it directly and is not installed in the wet environment.

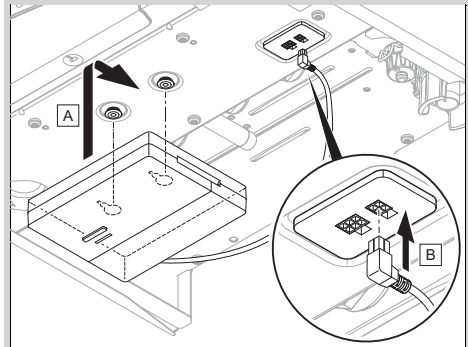

- ▶ Install the radio receiver unit below the heat generator.
- ▶ Connect the radio receiver unit to the direct connection below the heat generator. The LED lights up green after 20 seconds at the latest.

**Condition:** The heat generator does not have an option to connect it directly and/or is installed in the wet environment.

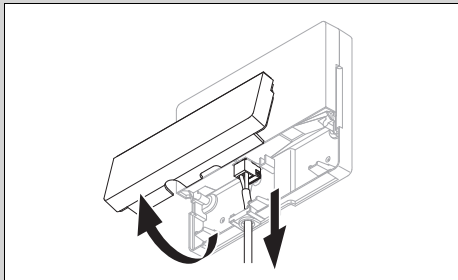

- ▶ Remove the flap on the radio receiver unit in accordance with the figure.
- ▶ Remove the existing cable for the direct connection.

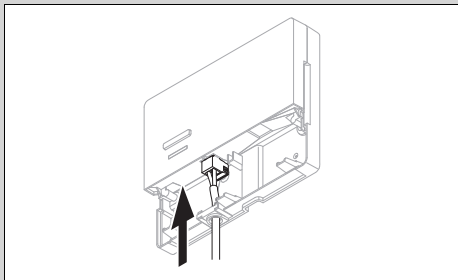

- ▶ Connect the eBUS cable, which is to be provided on-site, in accordance with the figure.
- ▶ Seal the flap on the radio receiver unit.

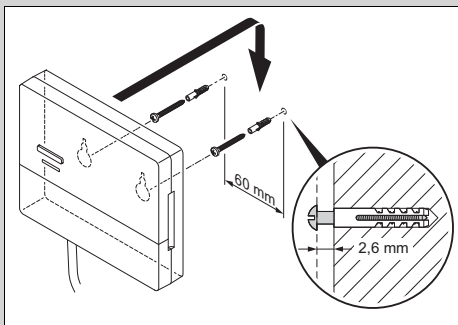

- ▶ Install the wall-mounting screws outside of the wet environment in accordance with the figure.
- ▶ Fit the radio receiver unit onto the wall-mounting screws.

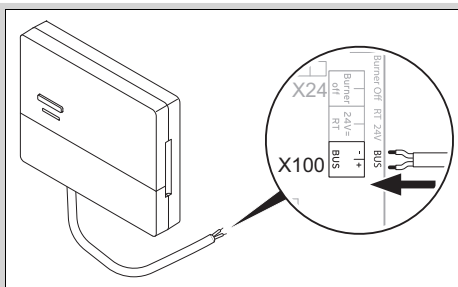

- ▶ When opening the electronics box in the heat generator, proceed as described in the installation instructions for the heat generator.
- ▶ Use an extension cable to connect the radio receiver unit to the eBUS interface in the heat generator's electronics box in accordance with the figure. The LED lights up green after 20 seconds at the latest.

### 3.5 Installing the control

1. Read the operating concept and the operating example described in the operating instructions for the control.
2. Stand next to the radio receiver unit.

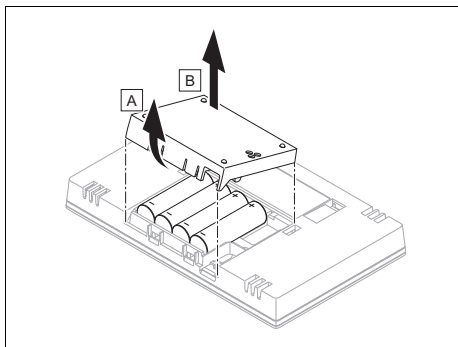

3. Open the control's battery compartment as shown in the figure.
4. Insert the batteries, making sure that the poles are the right way round.
  - ◁ The installation assistant starts.
5. Close the battery compartment.
6. Select the language.
7. Set the date.
8. Set the time.

- ◀ The installation assistant switches to the **System control reception strength** function.

**Condition:** Wireless outdoor temperature sensor available

- ▶ If a wireless outdoor temperature sensor is available, this must be paired. To do this, follow all of the installation instructions in its instructions.
- ▶ To pair the wireless outdoor temperature sensor, press the button on the radio receiver unit. The LED flashes green.
- ▶ Activate the outdoor temperature sensor as described in its instructions. The LED on the radio receiver unit flashes briefly. Once the pairing process is complete, the LED no longer lights up.
- ▶ Go to the chosen installation site for the wireless outdoor temperature sensor.
- ▶ If the reception strength at the chosen installation site is  $< 4$ , find a new installation site for the outdoor temperature sensor – one that has a reception strength of  $\geq 4$ .
- ▶ Install the outdoor temperature sensor at the installation site.

### Determining the control's installation site in the building

- Choose an installation site that meets the following requirements.
  - Internal wall of the main living room
  - Installation height: 1.3 ... 1.5 m
  - Not in direct sunlight
  - Not affected by heat sources

### Determining the reception strength of the control at the chosen installation site

- Go to the chosen installation site for the control.
- Close all doors behind you on the way to the installation site.
- Press the wake-up/sleep button on the upper side of the unit if the display is off.

**Condition:** The display is on, The display shows **Radio communication interrupted**

- ▶ Make sure that the power supply is switched on.

**Condition:** The display is on, **System control reception strength**  $< 4$

- ▶ Find an installation site for the control that is within the reception range.

**Condition:** The display is on, **System control reception strength**  $\geq 4$

- ▶ Mark the position on the wall where the reception strength is sufficiently high.

### Attaching the unit mounting bracket to the wall

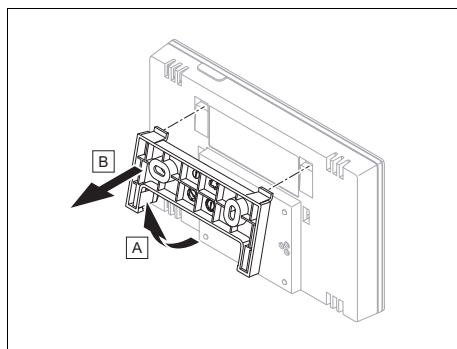

- Remove the unit mounting bracket from the control as shown in the figure.

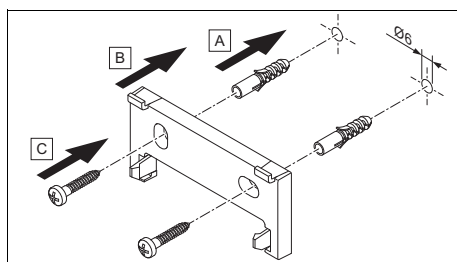

- Secure the unit mounting bracket in accordance with the figure.

## Fitting the control

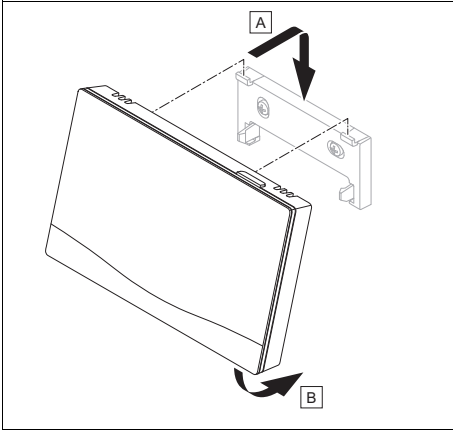

15. Fit the control to the unit mounting bracket as shown in the figure, making sure that it clicks into place.

## 4 -- Start-up

### 4.1 Prerequisites for starting up

- The control and, if required, the outdoor temperature sensor have been installed and wired.
- Start-up of all system components (except for the control) is complete.

### 4.2 Running the installation assistants

The installation assistant is at the **Language**: query.

The control's installation assistant takes you through a list of functions. For each function, you should choose the set value that is best suited to the heating installation being installed.

#### 4.2.1 Completing the installation assistant

Once you have gone through the installation assistant, **Select the next step**. appears on the display

**Installation configuration**: The installation assistant switches to the system con-

figuration for the installer level, in which you can further optimise the heating installation.

**Installation start**: The installation assistant switches to the basic display and the heating installation works with the values you have set.

### 4.3 Changing the settings later

All settings that you have made via the installation assistant can be changed again at a later date via the end user or installer level.

## 5 Fault and maintenance messages

### 5.1 Fault message

 with the text of the fault message appears in the display.

You can find fault messages under: **MENU** → **SETTINGS** → **Installer level** → **Fault history**

Troubleshooting (→ Appendix)

### 5.2 Maintenance message

 with the text of the maintenance message appears in the display.

Maintenance message (→ Appendix)

### 5.3 Changing the batteries



#### **Danger!**

#### **Risk of death caused by unsuitable batteries!**

If batteries – whether rechargeable or non-rechargeable – are replaced with the wrong type of battery, there is a risk of explosion.

- ▶ Ensure that you use the correct battery type when replacing batteries.

- ▶ Dispose of used batteries in accordance with the instructions in this manual.



**Warning.**

**Risk of chemical burns caused by leaking batteries!**

Corrosive battery fluid may leak out of used batteries.

- ▶ Remove any used batteries from the product as soon as possible.
- ▶ Before extended periods away from home, also remove batteries that are still charged from the product.
- ▶ Avoid skin or eye contact with leaking battery fluid.

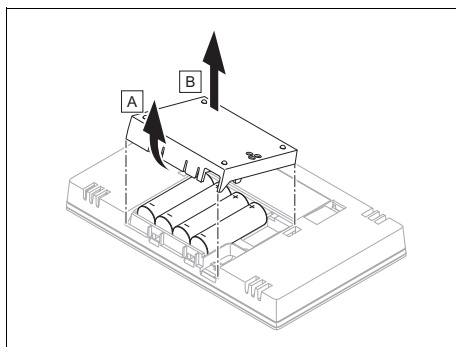

2. Open the battery compartment as shown in the figure.
3. Always change all the batteries at the same time.
  - Only use LR06 batteries
  - Do not use rechargeable batteries
  - Do not combine the batteries with other battery types
  - Do not combine new and used batteries
4. Insert the batteries, making sure that the poles are the right way round.
5. Do not short-circuit the connection contacts.
6. Close the battery compartment.

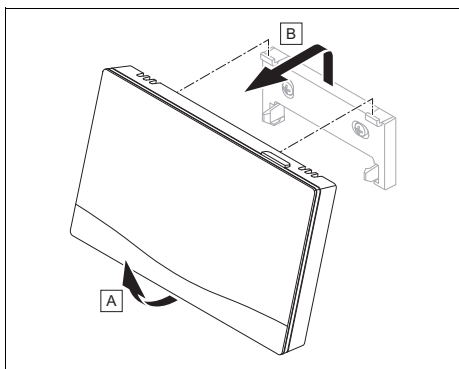

1. Remove the control from the unit mounting bracket as shown in the figure.

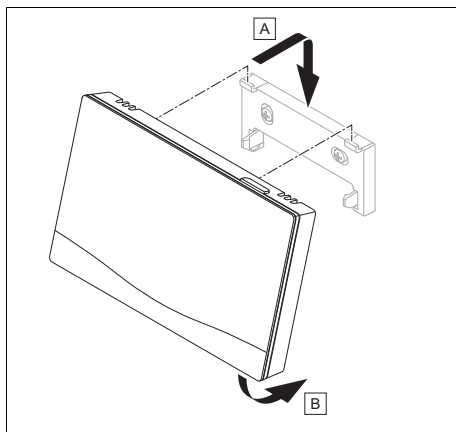

7. Clip the control into the unit mounting bracket as shown in the figure, making sure that it clicks into place.

## 6 Information about the product

### 6.1 Observing and storing other applicable documents

- ▶ Observe all of the instructions that are intended for you and are enclosed with the components of the installation.
- ▶ As the end user, keep these instructions and all other applicable documents safe for future use.

### 6.2 Validity of the instructions

These instructions apply only to:

- 0020260961

### 6.3 Data plate

The data plate is located on the rear of the product.

Information on the data plate	Meaning
Serial number	for identification; 7th to 16th digits = product article number
<b>sensHOME</b>	Product designation
V	Rated voltage
mA	Rated current
	Read the instructions

### 6.4 Serial number

You can call up the serial numbers under **MENU** → **INFORMATION** → **Serial number**. The 10-digit article number is located in the second line.

### 6.5 CE marking



The CE marking shows that the products comply with the basic requirements of the applicable directives as stated on the declaration of conformity.

The manufacturer hereby declares that the type of radio equipment that is described in these instructions complies with Directive 2014/53/EU.

The complete text for the EU Declaration of Conformity is available at:

<https://www.vaillant-group.com/doc/doc-radio-equipment-directive>

### 6.6 Guarantee and customer service

#### 6.6.1 Guarantee

You can find information about the manufacturer's guarantee in the Country specifics.

#### 6.6.2 Customer service

The contact details for our customer service are provided on the back page or on our website.

### 6.7 Recycling and disposal

- ▶ As the end user, observe the instructions in the "♻️ Recycling and disposal" section (see below).

#### ♻️ -- Recycling and disposal

This product is an electrical or electronic unit within the context of EU Directive 2012/19/EU. The unit was developed and manufactured using high-quality materials and components. These can be recycled and reused.

Find out about the regulations that apply in your country regarding the separate collection of waste electrical or electronic equipment. Correctly disposing of old units protects the environment and people against potential negative effects.

- ▶ Dispose of the packaging correctly.
- ▶ Observe all relevant regulations.

#### Disposing of the product



■ If the product is labelled with this symbol:

- ▶ In this case, do not dispose of the product with the household waste.
- ▶ Instead, hand in the product to a collection centre for waste electrical or electronic equipment.

## Disposing of batteries



■ If the product contains batteries that are labelled with this symbol:

- ▶ In this case, dispose of the batteries at a collection point for batteries.
  - ◁ **Prerequisite:** The batteries can be removed from the product without causing any destruction. Otherwise, the batteries are disposed of together with the product.
- ▶ In accordance with the legal regulations, the end user is obligated to return used batteries.

## Deleting personal data

Personal data may be misused by unauthorised third parties.

If the product contains personal data:

- ▶ Ensure that there is no personal data on or in the product (e.g. online login details or similar) before you dispose of the product.

## 6.8 Product data in accordance with EU Ordinance no. 811/2013, 812/2013

On units with integrated weather-compensated controls, including a room thermostat function that can be activated, the seasonal room-heating efficiency always includes the correction factor for control technology class VI. The seasonal room-heating efficiency may deviate if this function is deactivated.

Temperature control class	V
Contribution to the seasonal room-heating energy efficiency $\eta_s$	3.0 %

## 6.9 Technical data

### 6.9.1 Control

Battery type	LR06
Rated surge voltage	330 V
Frequency band	868.0 ... 868.6 MHz
Max. transmission power	25 mW
Range outdoors	≤ 100 m
Range indoors	≤ 25 m
Pollution degree	2
IP rating	IP 20
Protection class	III
Temperature for the ball pressure test	75 °C
Maximum permitted environmental temperature	0 ... 60 °C
Current room air hum.	35 ... 95 %
Mode of operation	Type 1
Height	109 mm
Width	175 mm
Depth	27 mm







### 6.9.2 Radio receiver unit

Rated voltage	9 to 24 V $\overline{---}$
Rated current	< 50 mA
Rated surge voltage	330 V
Frequency band	868.0 ... 868.6 MHz
Max. transmission power	25 mW
Range outdoors	≤ 100 m
Range indoors	≤ 25 m
Pollution degree	2
IP rating	IP 21
Protection class	III
Temperature for the ball pressure test	75 °C
Maximum permitted environmental temperature	0 ... 60 °C
Rel. room humidity	35 ... 90 %
Supply line cross-section	0.75 ... 1.5 mm <sup>2</sup>
Height	115.0 mm
Width	142.5 mm
Depth	26.0 mm

# Appendix

## A Troubleshooting, maintenance message

### A.1 Troubleshooting

Symptom	Possible cause	Measure
Display remains dark	The batteries are flat	<ol style="list-style-type: none"> <li>1. Change all the batteries. (→ Page 19)</li> <li>2. If the fault persists, inform the competent person.</li> </ol>
	Software error	<ol style="list-style-type: none"> <li>1. Press and hold the button on the top right of the control for longer than five seconds in order to force a restart.</li> <li>2. Switch the mains switch on the heat generator that feeds the control off and back on again.</li> <li>3. If the fault persists, inform the competent person.</li> </ol>
No changes in the display can be made via the control elements	Software error	<ol style="list-style-type: none"> <li>1. Press and hold the button on the top right of the control for longer than five seconds in order to force a restart.</li> <li>2. Switch off the mains switch on all heat generators for approx. 1 minute and then switch them on again.</li> <li>3. If the fault message persists, inform the competent person.</li> </ol>
Display: <b>F. Boiler fault</b> , the specific fault code (e.g. F.33) with the specific boiler is shown in the display	Boiler fault	<ol style="list-style-type: none"> <li>1. Reset the boiler by first selecting <b>Reset</b> and then <b>Yes</b>.</li> <li>2. If the fault message persists, inform the competent person.</li> </ol>
Display: You do not understand the set language	Incorrect language set	<ol style="list-style-type: none"> <li>1. Press  twice.</li> <li>2. Select the last menu item ( <b>SET-TINGS</b>) and confirm by pressing .</li> <li>3. Under  <b>SETTINGS</b>, select the second menu item and confirm by pressing .</li> <li>4. Select the language that you understand and confirm by pressing .</li> </ol>

### A.2 Maintenance messages

#	Code/meaning	Description	Maintenance work	Interval	
1	<b>Water deficiency: Follow the instructions in the heat gen.</b>	The water pressure is too low in the heating installation.	Refer to the operating instructions for the relevant heat generator for information on filling with water	See the operating instructions for the heat generator	

## B -- Troubleshooting, maintenance message

### B.1 Troubleshooting

Symptom	Possible cause	Measure
Display remains dark	The batteries are flat	► Change all the batteries. (→ Page 19)
	The product is defective	► Replace the product.
No changes in the display can be made via the control elements	Software error	1. Take all the batteries out. 2. Insert the batteries in the battery compartment, making sure that the poles are the right way round.
	The product is defective	► Replace the product.
It is not possible to switch to the installer level	You do not know the code for the installer level	► Reset the control to the factory settings. All set values will be lost.

### B.2 Troubleshooting

Code/meaning	Possible cause	Measure
Heat generator 1 communication interrupted	The cable is defective	► Replace the cable.
	Incorrect plug connection	► Check the plug connection.
<b>Sys. control room temperature sensor signal invalid</b> F.1361	Room temperature sensor defective	► Replace the control.

### B.3 Maintenance messages

#	Code/meaning	Description	Maintenance work	Interval	
1	<b>Heat generator 1 requires maintenance</b>	The heat generator requires maintenance work.	Refer to the operating or installation instructions for the relevant heat generator for information on the maintenance work required	See the operating or installation instructions for the heat generator	
2	<b>Water deficiency: Follow the instructions in the heat gen.</b>	The water pressure is too low in the heating installation.	Water deficiency: Follow the instructions in the heat generator	See the operating or installation instructions for the heat generator	
3	<b>Maintenance Contact:</b>	Date on which maintenance is due for the heating installation.	Carry out the required maintenance work	Date entered in the control	

# Index

<b>A</b>		Lines, selecting.....	16
Article number .....	21	<b>M</b>	
Attaching the unit mounting bracket, to the wall .....	18	Maintenance .....	19
Attaching, control to the unit mounting bracket.....	18	<b>O</b>	
<b>B</b>		Operating and display functions .....	9
Battery .....	5	<b>P</b>	
<b>C</b>		Polarity .....	16
Cable, maximum length.....	16	Prerequisites for starting up the heating installation .....	19
CE marking.....	21	Prerequisites, start-up .....	19
Changing the batteries .....	19	Preventing a malfunction.....	7
Competent person .....	4	<b>Q</b>	
Connecting the radio receiver unit to the heat generator .....	16	Qualification.....	4
Control elements .....	7	<b>R</b>	
<b>D</b>		Reading the article number .....	21
Determining the installation site of the control.....	18	Reading the serial number .....	21
Determining the reception strength of the control.....	18	Recycling.....	21
Determining the signal strength of the control.....	18	Regulations .....	5
Display.....	7	Running the installation assistants .....	19
Disposal.....	21	<b>S</b>	
Documents .....	21	Serial number .....	21
<b>F</b>		Setting the heat curve .....	7
Fault .....	19	<b>T</b>	
Faults.....	19	Tool .....	5
Fitting the control, to the unit mounting bracket.....	19		
Fitting, control to the unit mounting bracket.....	19		
Frost .....	5		
<b>I</b>			
Installing the radio receiver unit, on the heat generator .....	16		
Installing the radio receiver unit, on the wall .....	16		
Installing, radio receiver unit on the heat generator .....	16		
Installing, radio receiver unit on the wall .....	16		
Intended use.....	4		
<b>L</b>			
Lines, minimum cross-section .....	16		