

SHOWERMATE

Universal Twin Pumps

Showermate Universal Twin shower pumps can be used to pump the hot and cold water supplies to a shower or bathroom as required. High quality, high performance compact pump supplied with four 15 mm anti-vibration flexible hoses with integral isolation valves on the inlet hoses.

All Showermate Universal pumps are suitable for use in open vented (gravity fed) systems for both positive & negative head applications.



Features

- 3 year warranty
- 2.0 and 2.6 bar options
- Suitable for positive or negative head applications
- High quality, high performing plastic pump supplied with 15 mm flexible hoses with integral ISO valves on inlet hoses
- Quiet operation
- WRAS approved materials
- Continuously rated
- Anti-vibration feet
- EPDM/PTFE/Al. Oxide pump seal
- Pre-wired with 1.5 metre power cable

Application

- Low pressure gravity systems – boosting hot or cold water supplies to a single shower or to up to four outlets within a bathroom
- Showermate Universal pumps are suitable for use where there is less than 1 litre/min gravity flow from the outlet(s) to be boosted

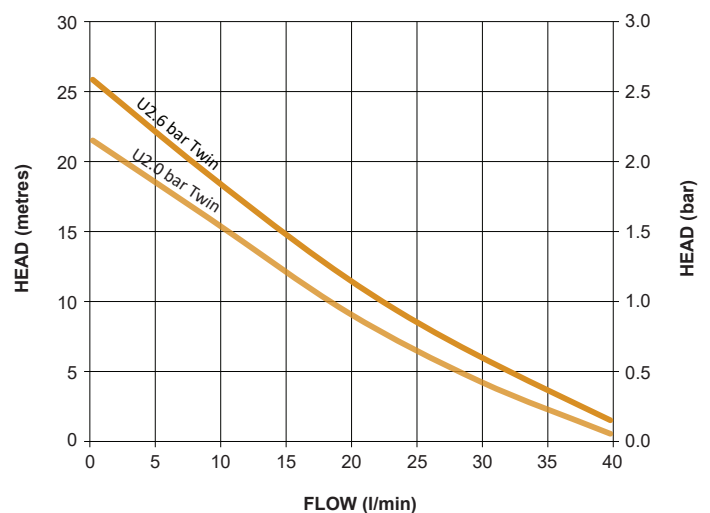

Pump Model		U2.0 bar Twin 47376	U2.6 bar Twin 47377
General	Warranty	3 years	
	Approvals	UKCA, CE	
Features	Pump type	Peripheral	
	Pump control	Pressure & flow switch	
	Anti-vibration feet	✓	✓
	Flexible hoses	4	4
	Run on timer	3 sec	3 sec
	Dry run protection	✓	✓
	Typical noise	58 dB(A)	60 dB(A)
Performance	Maximum head – closed valve	2.0 bar (20 metres)	2.6 bar (26 metres)
	Performance @ 9 l/min	1.6 bar (16 metres)	1.9 bar (19 metres)
	Performance @ 18 l/min	1.1 bar (11 metres)	1.3 bar (13 metres)
	Maximum flow	40 l/min	42 l/min
	Maximum static inlet pressure	6 metres	
	Maximum static outlet pressure	6 metres	
	Maximum working pressure*	400 kPa (4.0 bar)	
	Maximum ambient air temperature	40 °C	
	Min / Max water temperature**	Min 4 °C / Max 65 °C	
	Flow switch sensitivity	0.8 l/min (approx)	
	Pressure vessel air pre-charge	1.5 bar (21.75 psi)	
Materials	Pump body	Plastic	
	Impeller	Plastic	
	Mechanical seal	EPDM / PTFE / Al. Oxide	
Connections	Pump connections	G ¾ M	
Flexible hoses	Connections	G ¾ F x 15 mm push-fit x 200 mm long, isolating valves on inlet hoses	
Motor	Type	Induction (auto-reset thermal trip)	
	Duty rating	Continuous (S1) @ 9 l/min and above***	
Electrical	Power supply (Vac/Ph/Hz)	230 V a.c. / 1 / 50 Hz	
	Power consumption – P1	430 Watts	495 Watts
	Current – full load	1.9 Amps	2.2 Amps
	Fuse rating	5 Amps	
	Power cable length	1.5 metres (pre-wired to terminal block)	
Physical	Enclosure protection	IP22	
	Length	281 mm	
	Width	154 mm	
	Height – excluding hoses	282 mm	
	Weight – including fittings	6.1 Kg	6.1 Kg

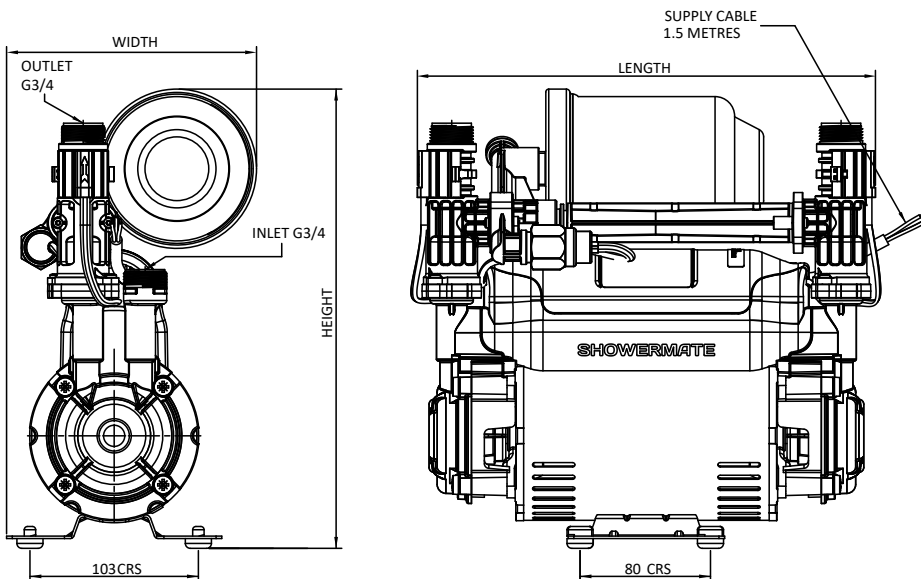

* The maximum pressure that can be applied to the pump under any installation conditions.

** A stored water temperature of 60 °C is considered sufficient to meet all normal requirements and will minimise deposition of scale in hard water areas.

Stuart Turner Limited reserves the right to amend specifications without notice.

Stuart Turner Ltd, Henley-on-Thames, Oxfordshire RG9 2AD Tel: +44 (0) 1491 572655 Fax: +44 (0) 1491 573704

TechAssist Helpline +44 (0) 800 31 969 80

www.stuart-turner.co.uk

Pt. No. 19892 Issue 5020/04-01

Check out our full range of Showers

Electric Showers

Digital Showers

Mixer Showers

Power Showers

Smart Showers

Shower Towers

From Top Shower Brands

Mira Showers

Aqualisa Showers

Triton Showers

Gainsborough Showers

Shower Pumps can upgrade your showering experience even more

Stuart Turner Shower Pumps

Salamander Shower Pumps

Grundfos Shower Pumps

plumbworld
Big brands, small prices.