

**stuart**

## CH Single Stage Automatic Flow Switch

The CH Single Stage Automatic Flow Switch range of centrifugal pumps are ideal for the pressurisation of water to outlets in a positive head application, where a gravity flow of approx. 1 l/min already exists.



### Features

- Fully automatic control - positive head
- No on-site setting/commissioning
- Built in 'no water' cut out
- No pulsing in operation
- Easy installation
- Reliable
- Quiet operation

### Application

- The range is suitable for commercial or domestic use, pumping hot or cold water

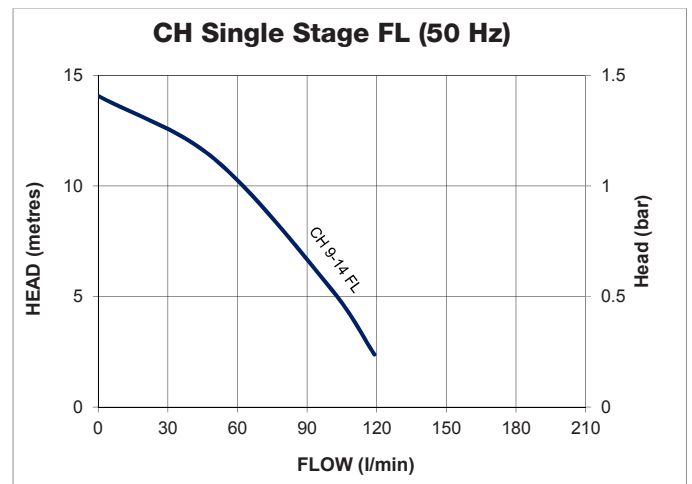

For further advice on selecting the correct pump call or e-mail [info@stpumps.co.uk](mailto:info@stpumps.co.uk)

**pumpassist**  
HELPLINE +44 (0) 800 31 969 80

# stuart

Pump Model		CH 9-14 FL 50 Hz 46387
General	Guarantee	2 years
	WRAS approval	Approved materials
Features	Pump type	Centrifugal
	Mechanical seal	EPDM / PTFE / Al. Oxide
	Anti-vibration feet	✓
	Inlet strainer(s)	✓
	Flexible hoses	2
	Dry run protection	✓
Materials	Pump body	Brass
	Impeller	Plastic
Performance	Maximum head (closed valve)	1.4 bar
	Performance @ 45 l/min	1.2 bar
	Performance @ 90 l/min	0.7 bar
	Maximum flow	120 l/min
	Minimum static inlet pressure	1 metre
	Maximum static inlet pressure	14 metres
	Maximum working pressure*	600 kPa (6 bar)
	Maximum ambient air temperature	40 °C
	Min / Max water temperature**	Min 4 °C / Max 65 °C
Connections	Pump connections	G 1 female
	Connections	G 1 male x G 1 female x 300 mm long
Motor	Type	Induction, auto-reset thermal trip
	Duty rating	Continuous (S1)
Electrical	Power supply / phase / frequency	230 V a.c. / 1 / 50 Hz
	Current (full load)	2.0 Amps
	Power consumption	445 Watts
	Fuse rating	5 Amps
	Power cable (pre-wired)	1.5 metres
Physical	Enclosure protection	IPX4
	Length	273 mm
	Width	133 mm
	Height (excluding hoses)	264 mm
	Weight (including fittings)	7.7 Kg

\* The maximum pressure that can be applied to the pump under any installation conditions.

\*\* A stored water temperature of 60 °C is considered sufficient to meet all normal requirements and will minimise deposition of scale in hard water areas.

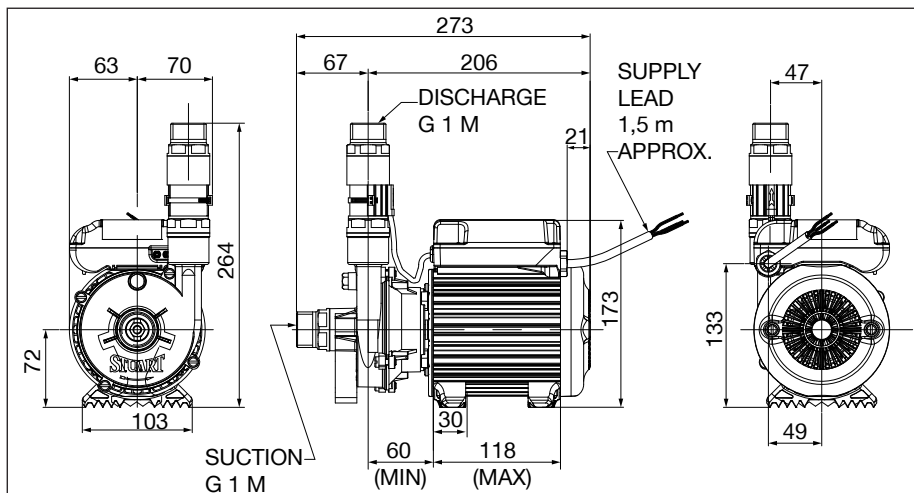

Stuart Turner Limited reserves the right to amend specifications without notice.

Stuart Turner Ltd, Henley-on-Thames, Oxfordshire RG9 2AD

Tel: +44 (0)1491 572655 Fax: +44 (0)1491 573704

www.stuart-turner.co.uk

Pt. No. 20610 Issue 4117/1-01

**pumpassist**  
HELPLINE +44 (0) 800 31 969 80

## Check out our full range of Plumbing Supplies

Plumbing wastes / Plumbing traps

Plumbing Consumables

Plumbing Tools

Toilet Fittings

Brassware

Valves

Plumbing Fittings

**plumbworld**  
**Big brands, small prices.**