

## Leap Pivot Door (S43A)

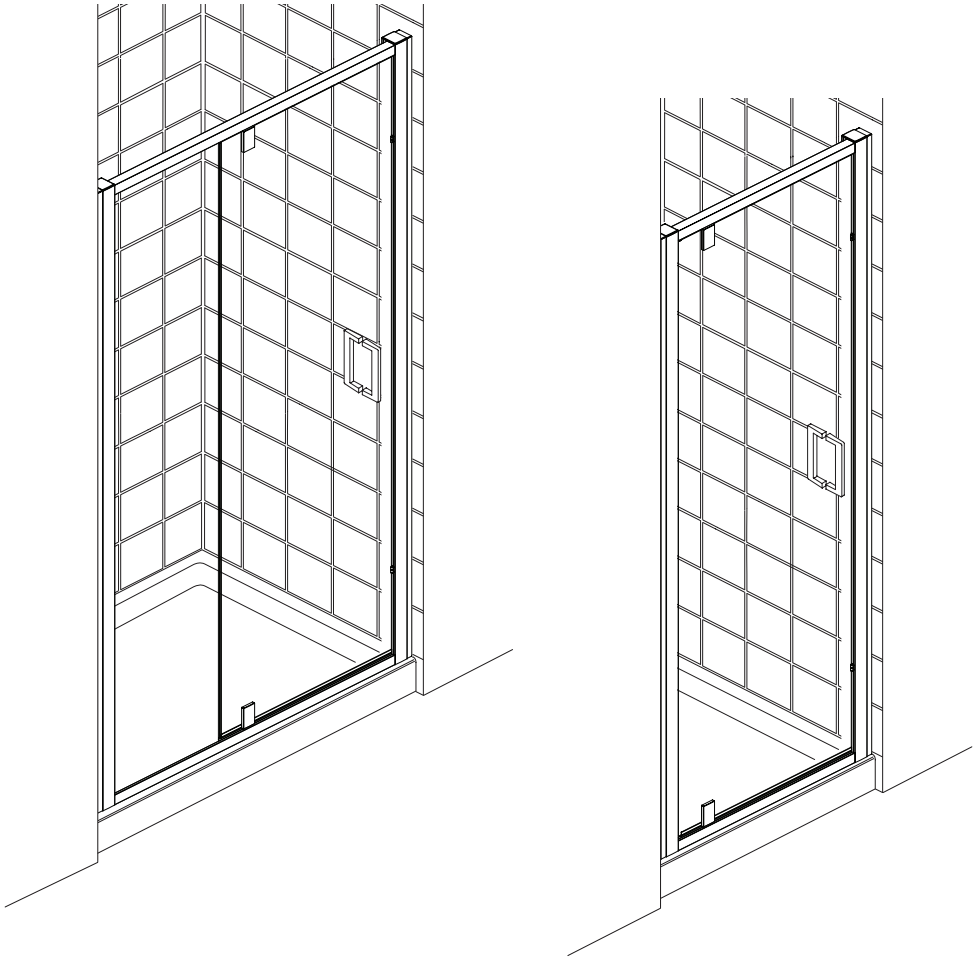

These instructions must be left with the user

Installation Guide

***mira***  
SHOWERS

# INTRODUCTION

Thank you for purchasing a quality Mira product. To enjoy the full potential of your new product, please take time to read this guide thoroughly, having done so, keep it handy for future reference.

The following pages aim to provide comprehensive installation instructions, plus advice on how to care and maintain your product.

We recommend that the unit is installed by a qualified plumber or engineer.

## GENERAL INFORMATION

### General

1. Read all of these instructions and retain this guide for later use.
2. Pass on this guide in the event of change of ownership of the installation site.
3. Follow all warnings, cautions and instructions contained in this guide.
4. Remove all protective tape from the enclosure before installation.
5. Excessive flow rates may lead to overflowing and leaking.
6. Water Spray may extend beyond the entrance of walk-in enclosures and we recommend tiling of the adjacent area.
7. We recommend a drainage test is carried out to ensure the waste is adequate for the flow delivered.
8. Doors that open outwards may drip water onto floor, ensure the floor covering will not be affected by water.
9. Walk ins and divider panels are designed to minimise water escaping outside the enclosure but by their very nature are not fully water tight.

### Safety Information

1. Care should be taken when drilling into walls and floors to avoid any hidden pipes or wires.
2. We strongly recommend that all glass panels are moved by a minimum of two people and that any protective packaging along the glass edges is kept in place for as long as possible to prevent damage before installation.
3. During installation we recommend additional help in lifting heavy doors and side panels.
4. Wear protective footwear when lifting panels.
5. Wear safety glasses when drilling.

### Before Fitting the Enclosure

1. Ensure the tray is level and walls are vertical and square.
2. Shower fittings should be positioned such that water discharges down the centre line of a bath or across the opening of a shower cubicle door.
3. Ensure water is not directed at the shower door or side panels. This could result in water spraying outside of the enclosure.
4. Ensure the door opening is positioned correctly and is adequate for all users.
5. Ensure there is a complete silicone seal between the tray and finished wall.
6. Ensure the door is undamaged and no parts are missing.

7. Ensure the size of door/panel is suitable for the installation. Tempered safety glass cannot be cut.
8. Ensure nothing can impact the door or glass panels during operation.

## When Fitting the Enclosure

1. The wall channels must be installed onto a tiled or waterproof finished flat and even wall surface. Failure to do so will result in an unsatisfactory seal, which may cause property damage.
2. We recommend our enclosures are fitted onto shower trays.

**Warning!** The use of grout/tile cleaners, scale removers, abrasive scourers, drain unblockers and other powerful detergents may lead to damage of metallic, plated and plastic surfaces, including the tray and shower waste.

## Use of the Enclosure

1. High water pressure and flow may lead to excessive splashing causing water to escape outside of the enclosure.
2. In certain circumstances such as cleaning, water sprayed directly at the seals may escape outside of the enclosure.

## GUARANTEE

For **domestic installations**, your enclosure has the benefit of our lifetime guarantee which starts from date of purchase.

For **non-domestic installations**, we guarantee the product against any defect in materials or workmanship for a period of one year from the date of purchase.

For terms and conditions refer to the back cover of this guide.

## RECOMMENDED USAGE

Domestic	✓
Light Commercial	✓
Heavy Commercial	✗
Healthcare	✗

## TOOLS REQUIRED

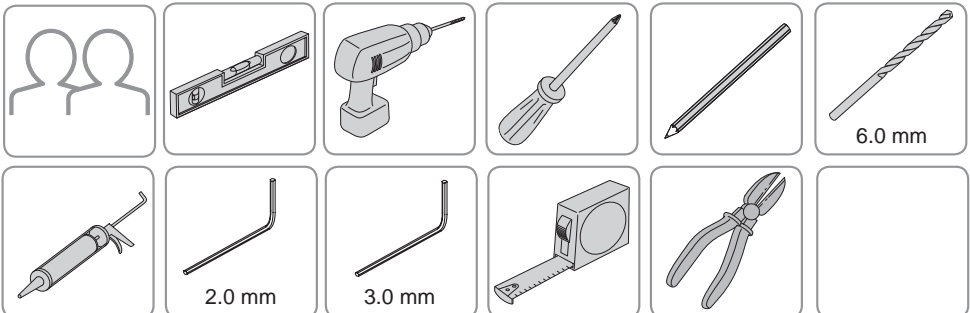

# PACK CONTENTS

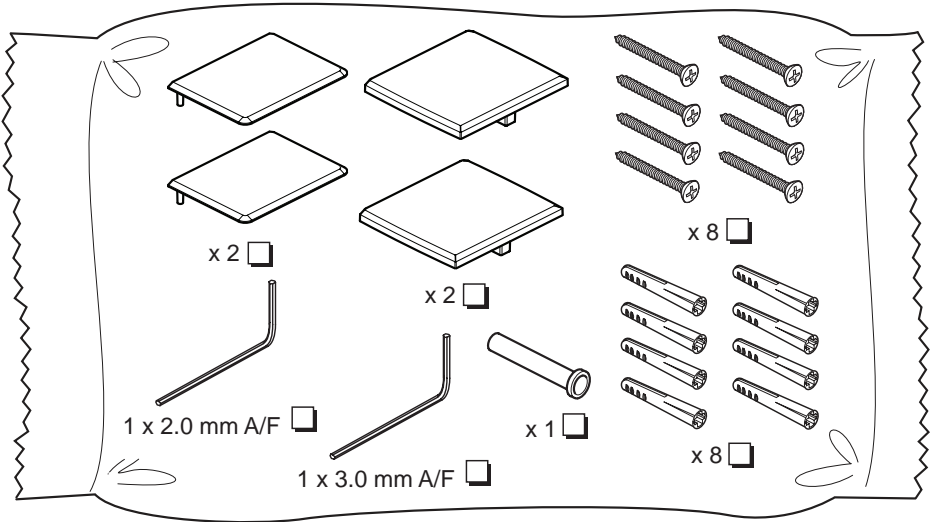
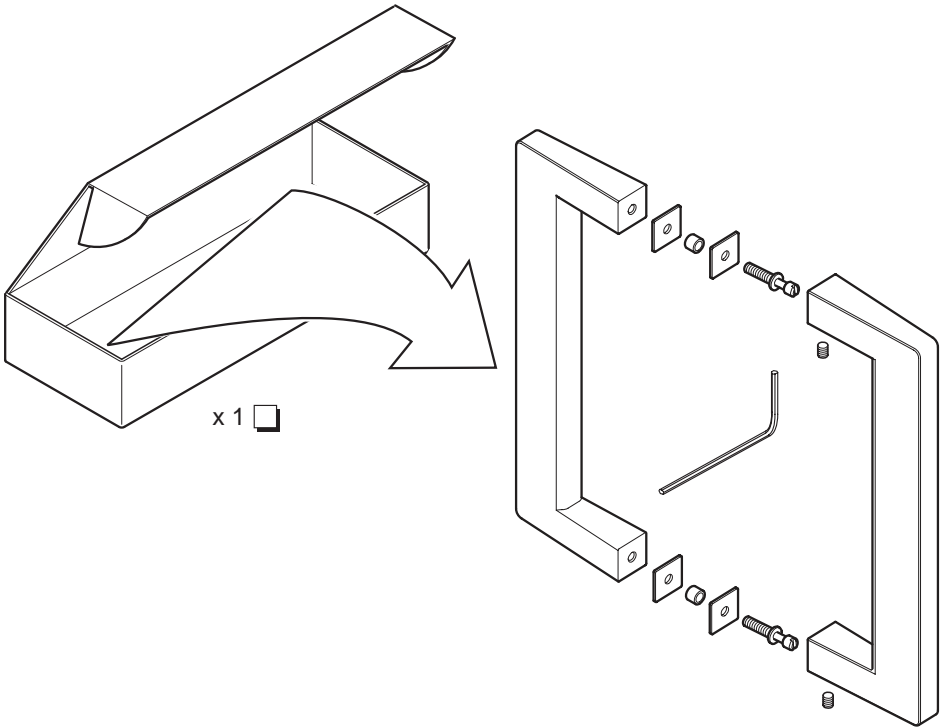

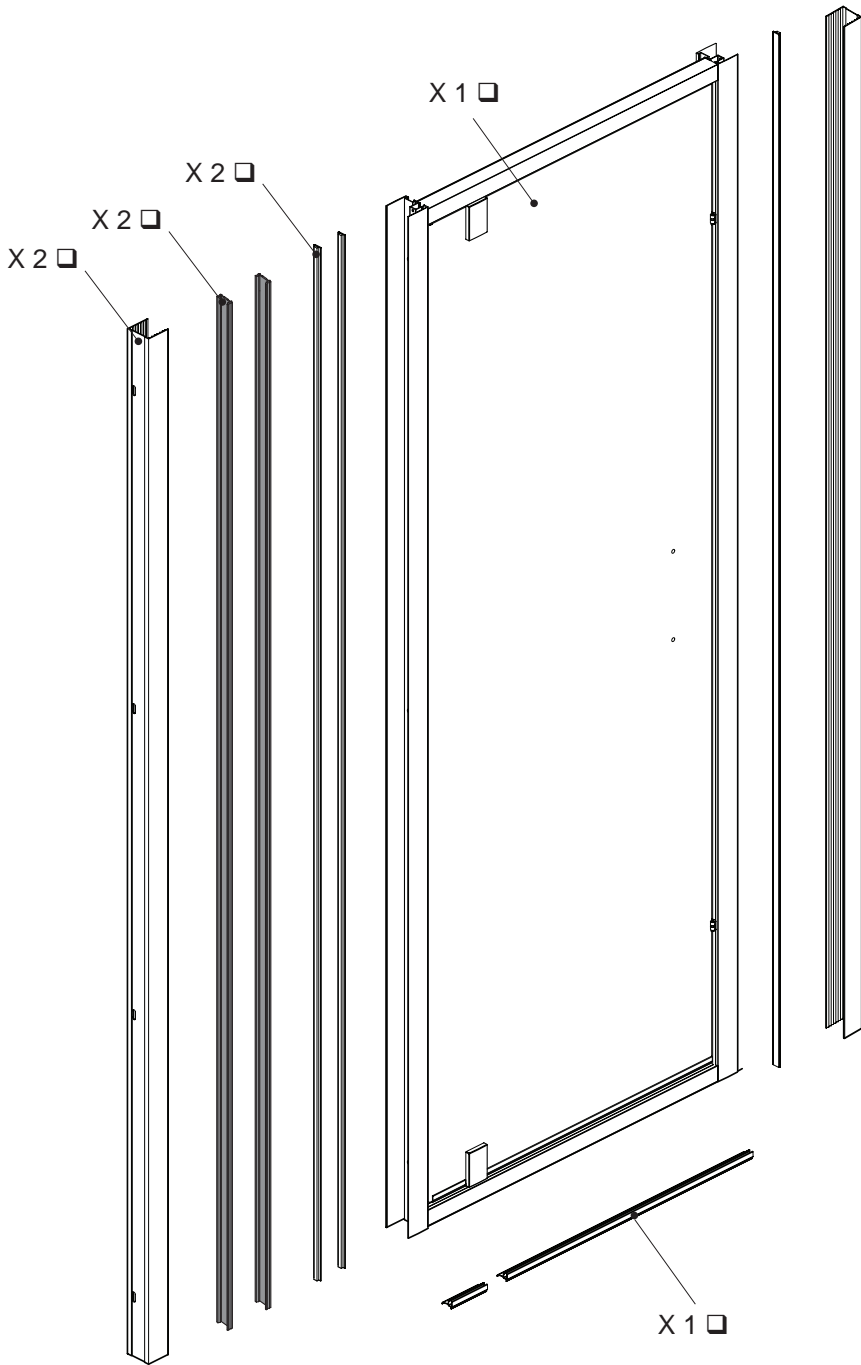

# INSTALLATION

1

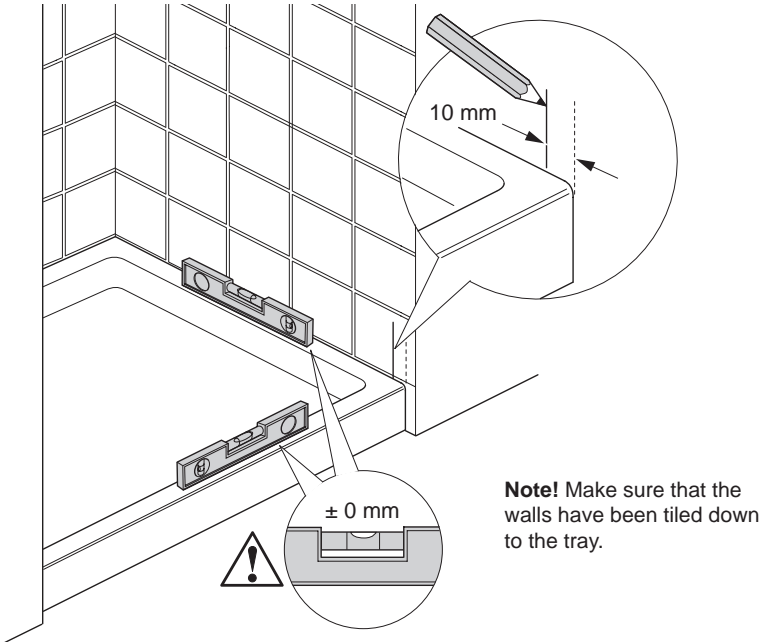

Height of Enclosure (mm)	1900		
Min/Max Frame Adjustment	Enclosure Size	Minimum (mm)	Maximum (mm)
	760	710	770
	800	750	810
	900	850	910
	1000	950	1010
	1200	1150	1210

- (a) Install the shower tray in accordance with the manufacturer's instructions.  
**Caution!** Make sure that the shower tray is level and that the walls are vertical and square.

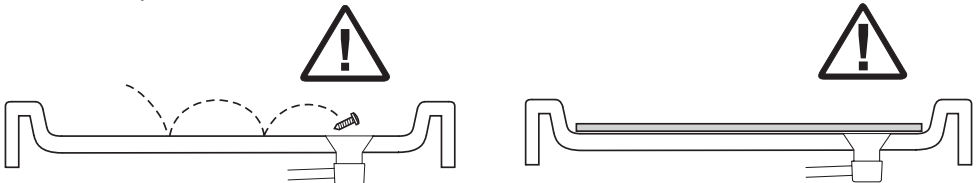

**Note!** Cover the tray waste to prevent the loss of small parts.

**Note!** Protect the tray surface during enclosure installation.

2

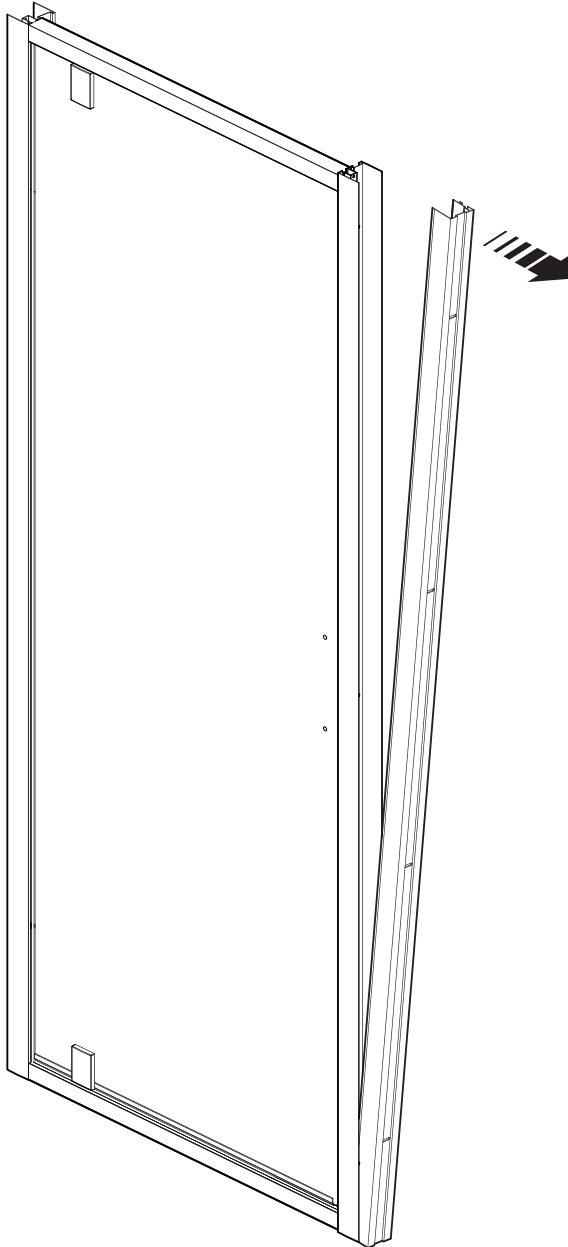

(a) Remove the wall channel from the door.

3

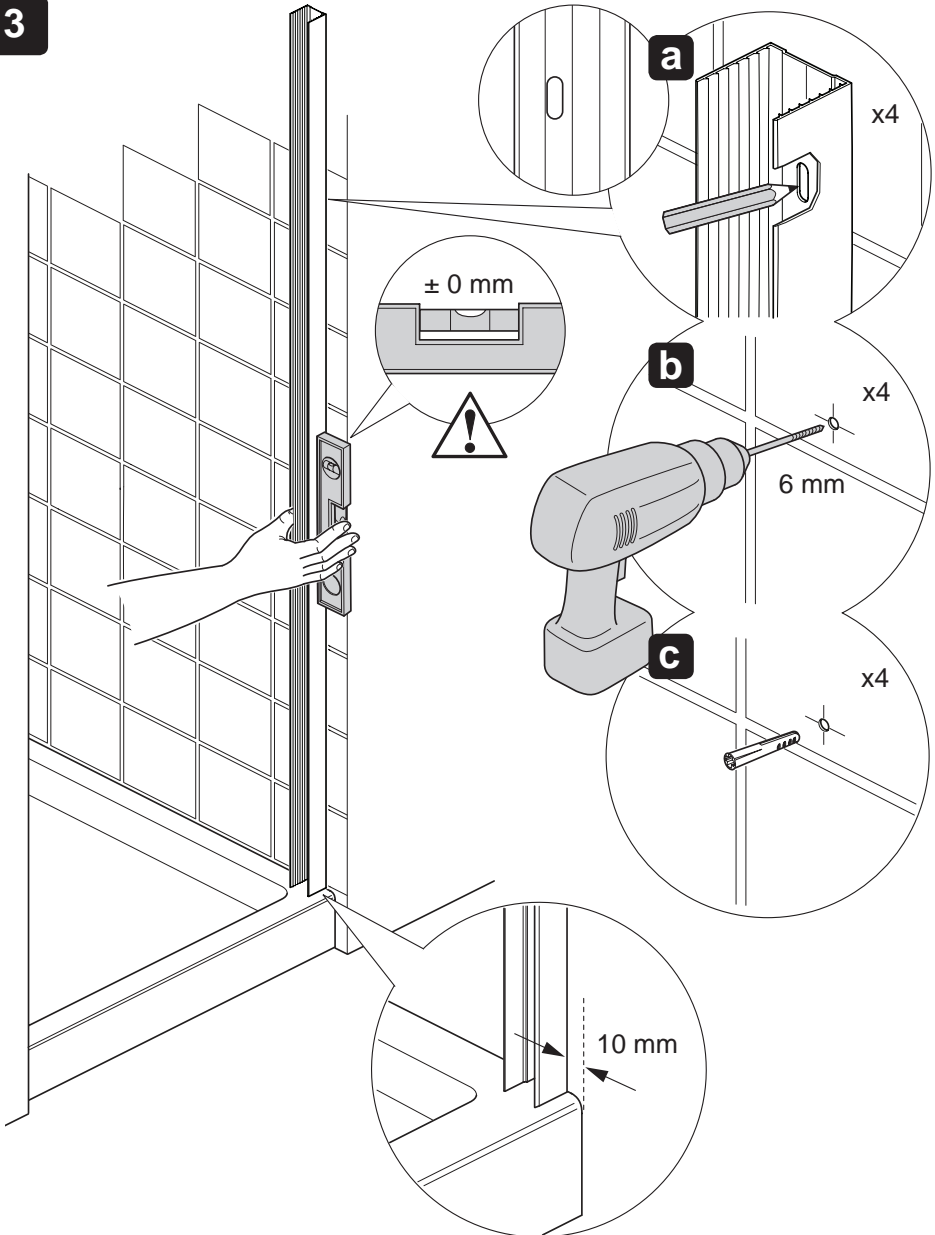

- (a)** Position the wall channel (handle side) on the wall. Using a spirit level make sure that it is upright.
- (b)** Mark the position of the fixing holes, then remove the wall channel.
- (c)** Drill with a 6 mm masonry bit (not supplied) and plug using the wall plugs (supplied).



4

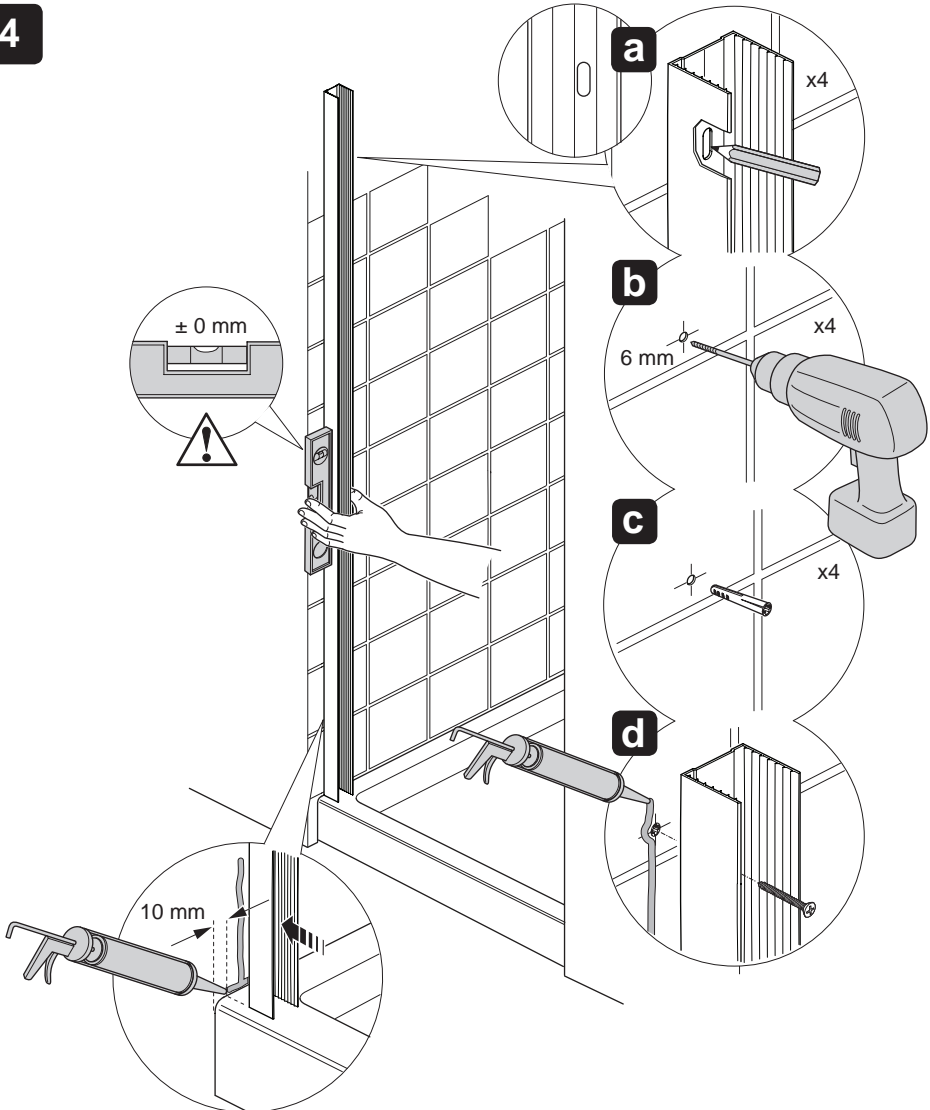

- (a) Position the second wall channel (hinge side) on the wall. Using a spirit level make sure that it is upright.
- (b) Mark the position of the fixing holes, then remove the wall channel.
- (c) Drill with a 6 mm masonry bit (not supplied) and plug using the wall plugs (supplied).
- (d) Apply silicone sealant along the length of the wall and at the bottom where the wall channel will be placed, including the top of the tray.
- (e) Position the wall channel on the wall and install the fixing screws.
- (f) Fully tighten the fixing screws, making sure that the wall channel is upright.

5

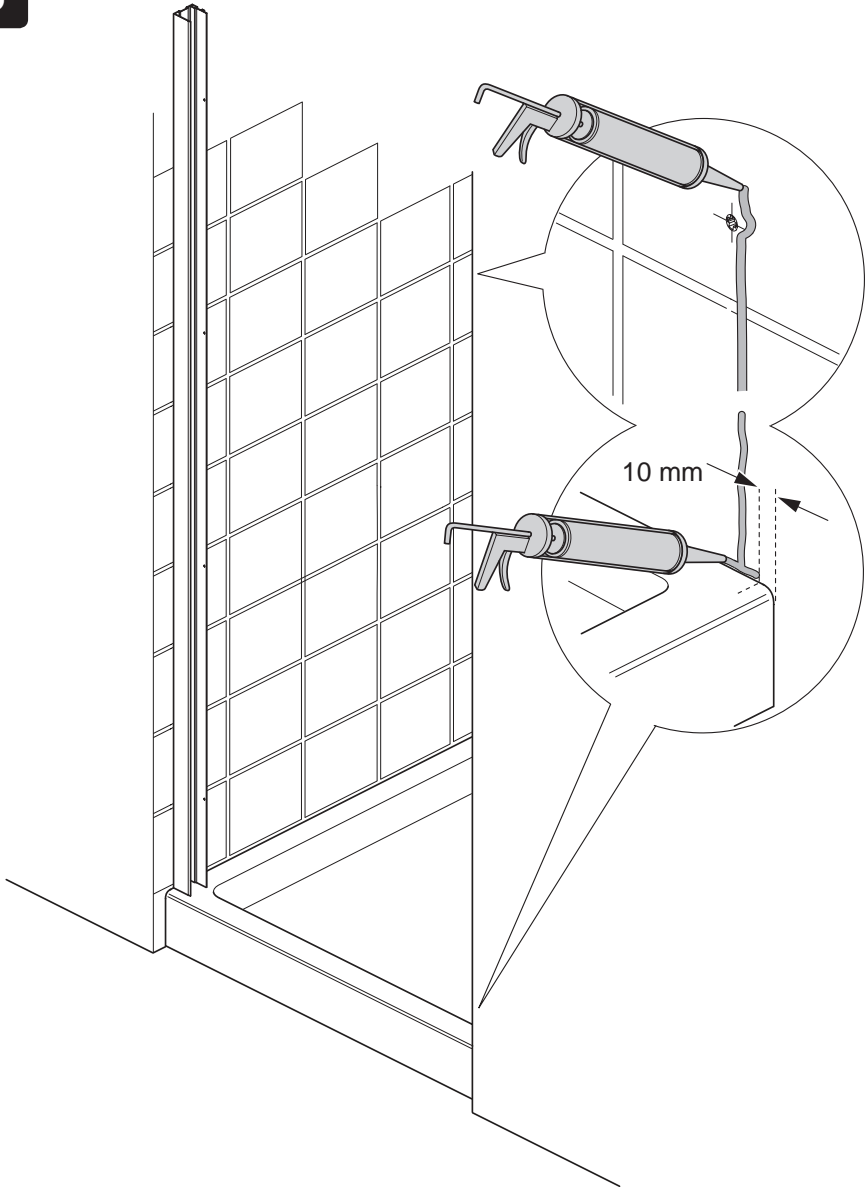

(a) Apply silicone sealant along the length of the wall and at the bottom where the wall channel will be placed.

6

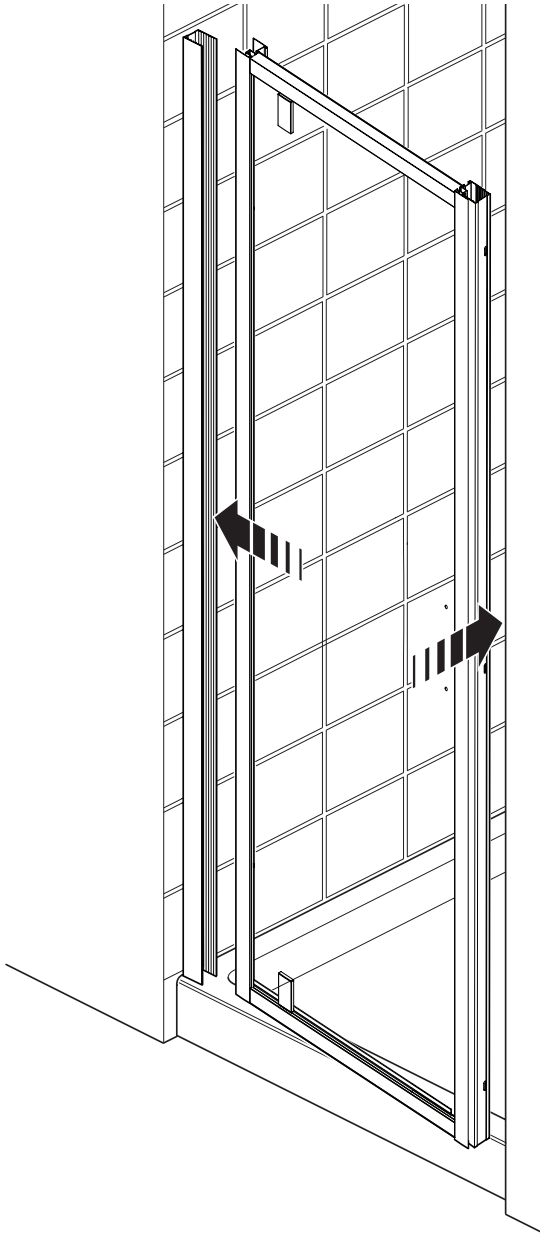

- (a) Install the first wall channel into the door frame and hold in position.
- (b) Install the door frame over the wall channel that had been secured to the wall earlier. **Make sure that you do not smudge the silicone sealant applied in the previous step.**
- (c) Adjust the door frame so that it is in the correct position.

7

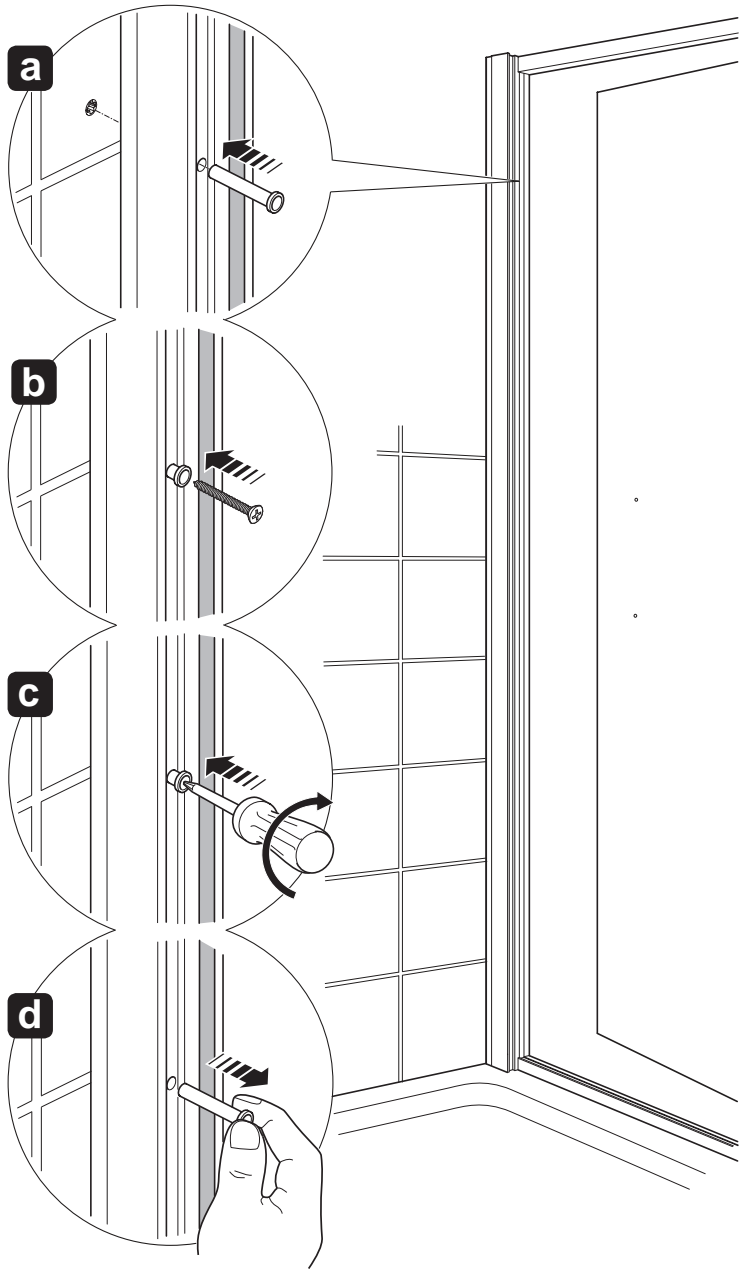

- (a) Open the door.
- (b) Install the wall channel fixing screws through the access holes in the door frame.  
**Note!** The plastic sleeve is provided as an installation aid.
- (c) Fully tighten the fixing screws, making sure that the wall channel is upright.

8

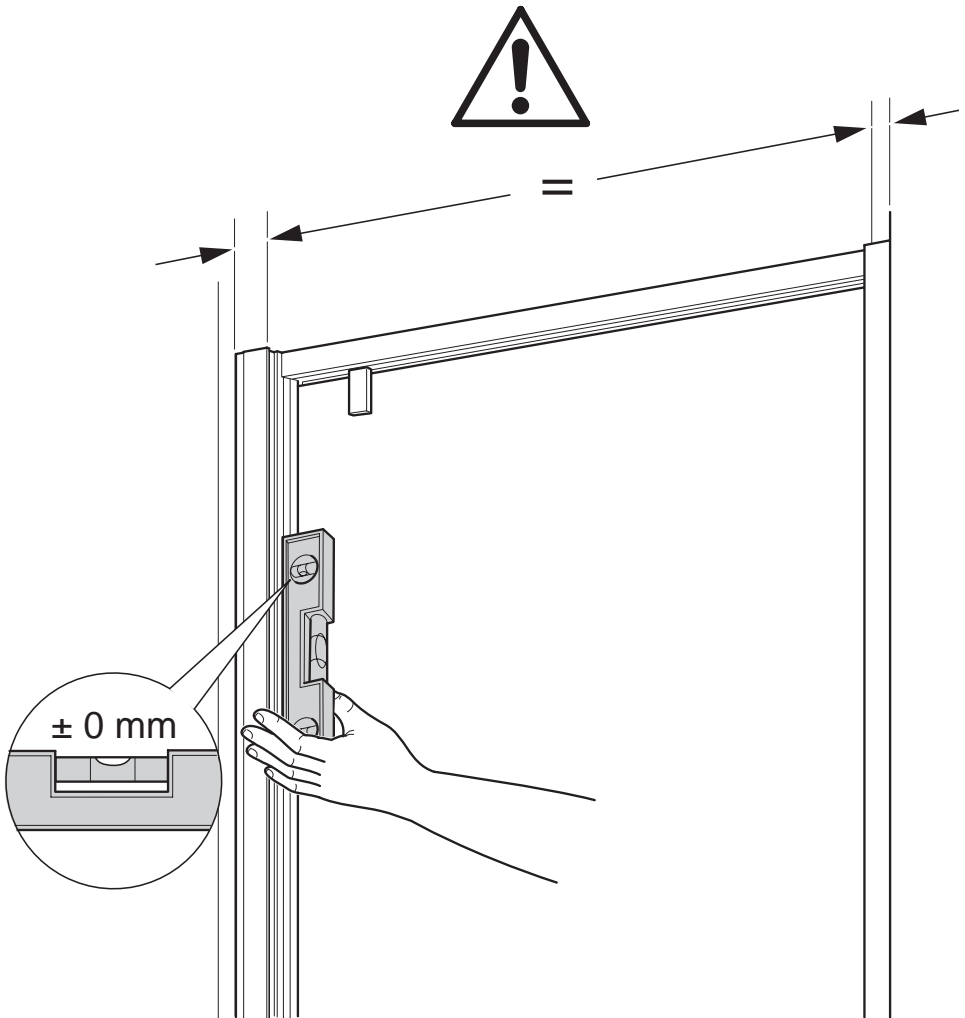

- (a) Centralise the door frame within the wall channels, making sure that the door frame is square.

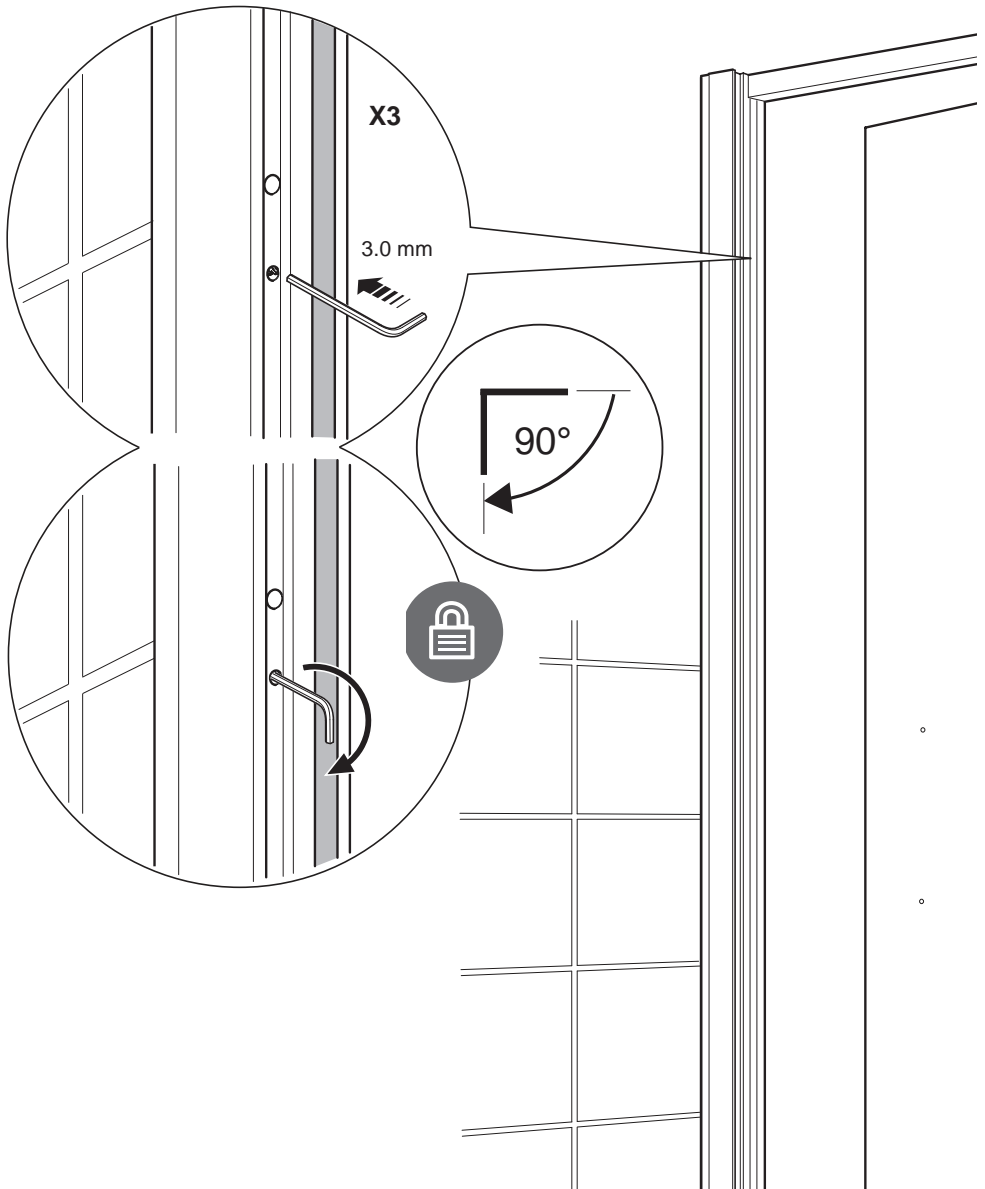

- (a) Using the 3.0 mm hexagonal wrench (supplied), turn through 90° clockwise in three locations to lock the door frame in position. Repeat this on the other wall channel.

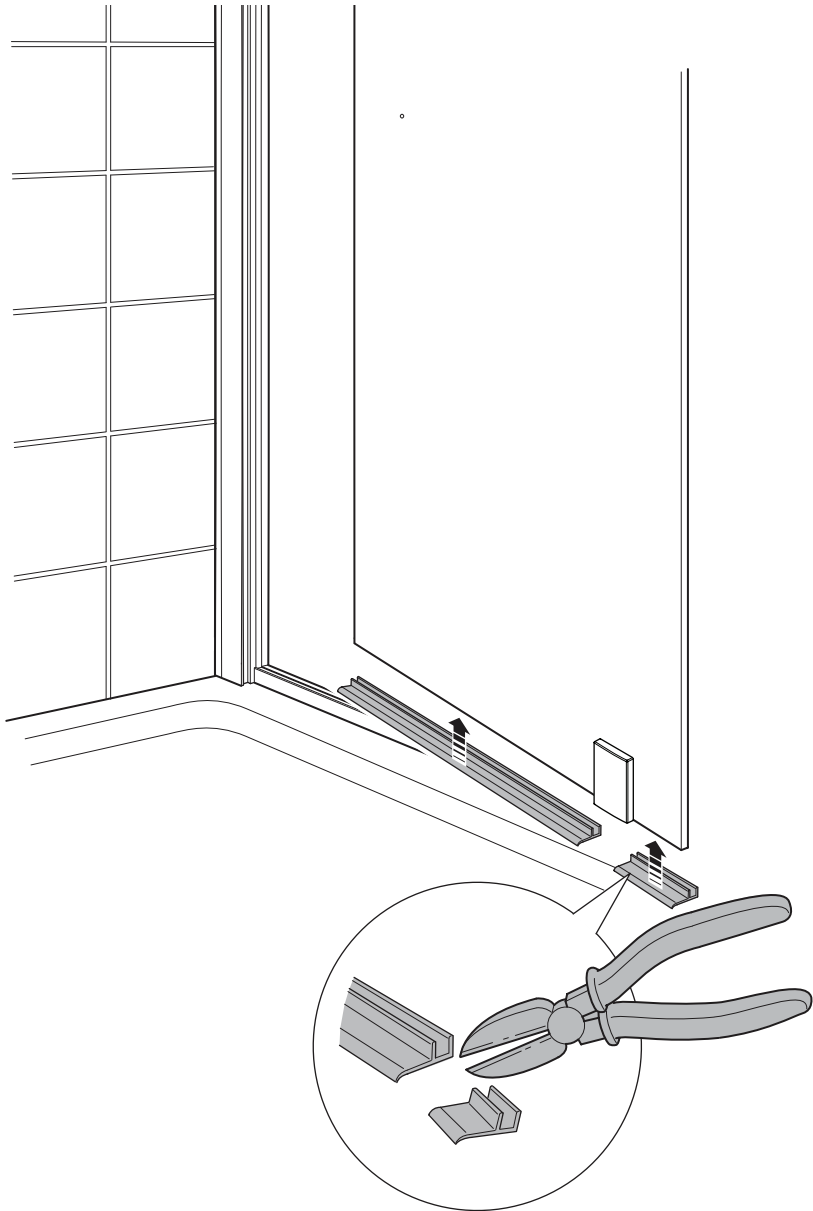
**10**

- (a)** Install the splash seal to the door as shown above. For the inline pivot door the short seal will have to be cut to length after adjustment of the door in step 14.

11

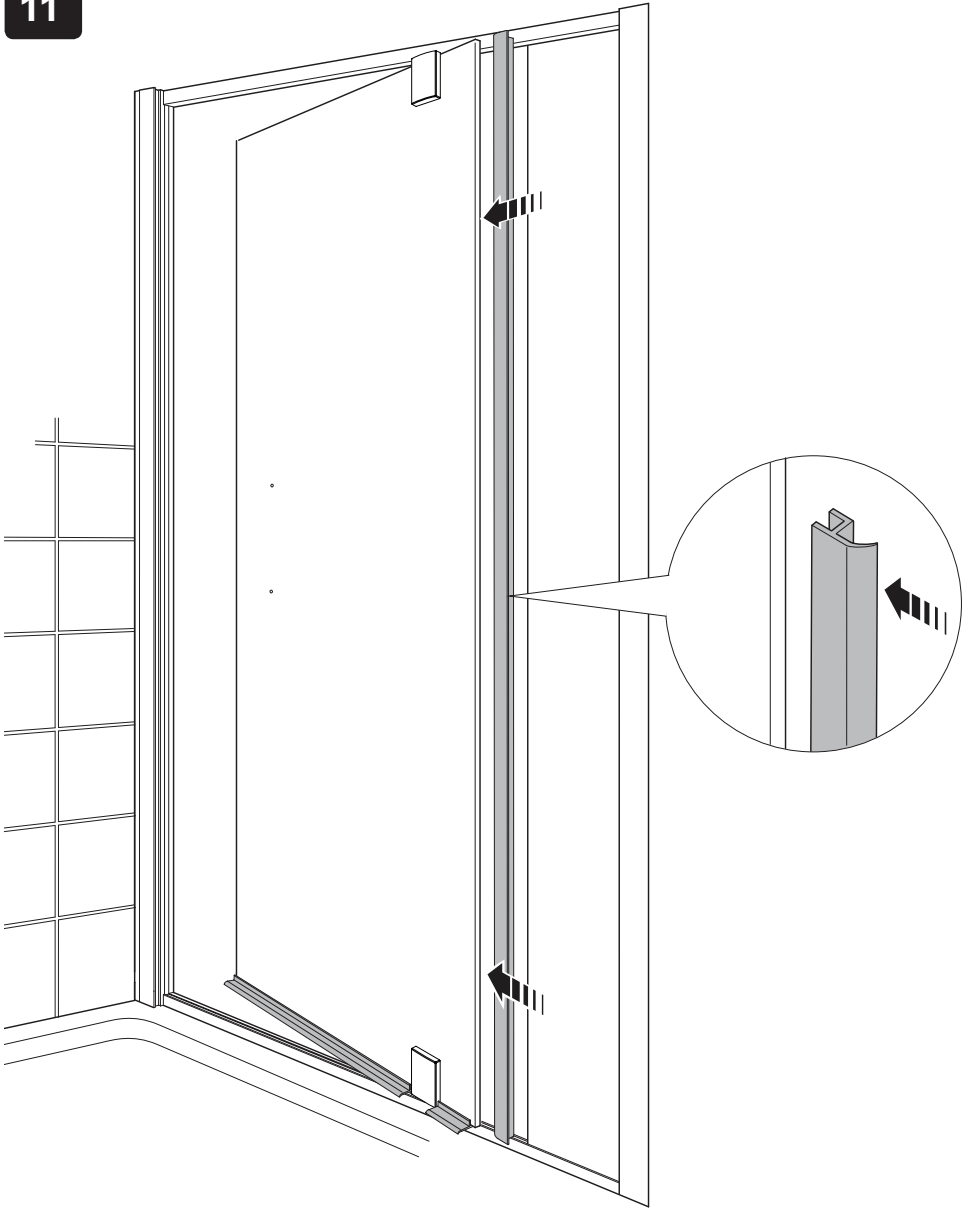

(a) Install the panel seal to the door shown above.



12

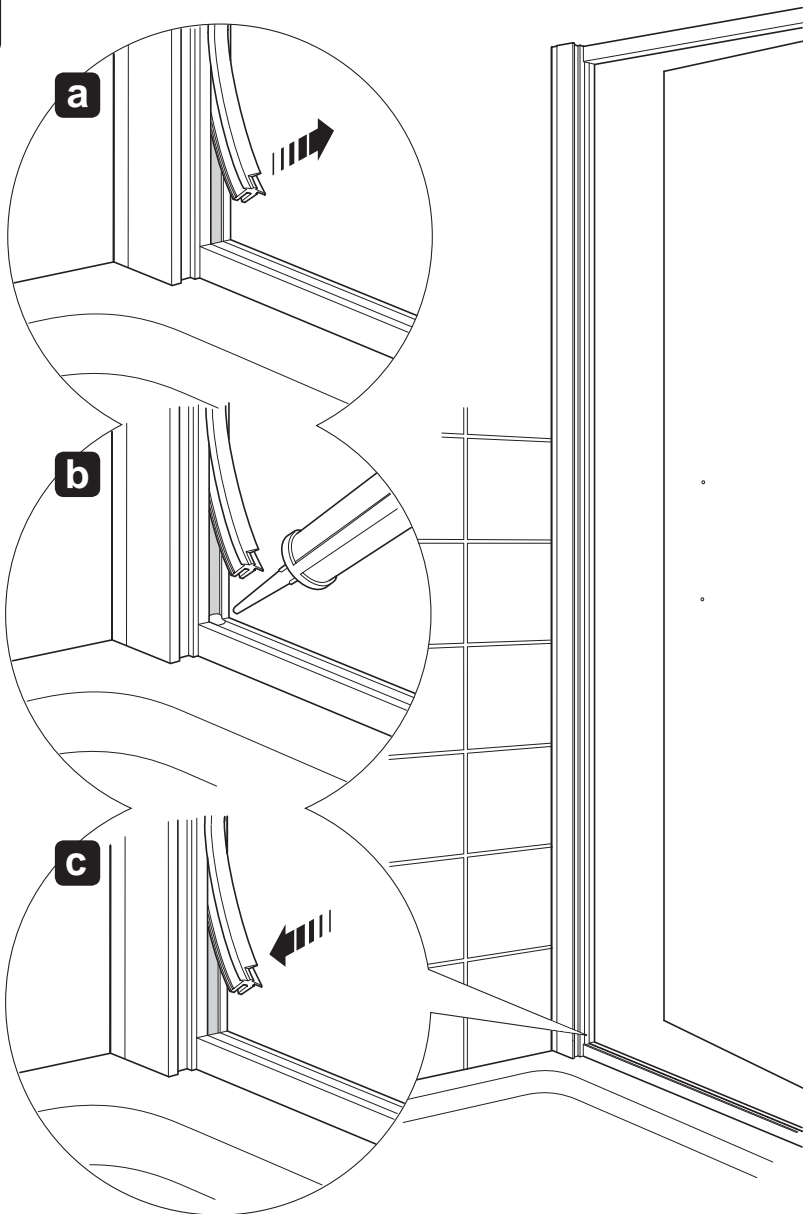

- (a)** Partially remove the door sealing strips as shown above.
- (b)** Apply a small amount of sealant in accordance with the sealant manufacturers instructions as shown above.
- (c)** Fit the door sealing strips back in position. Remove any excess silicone sealant.

13

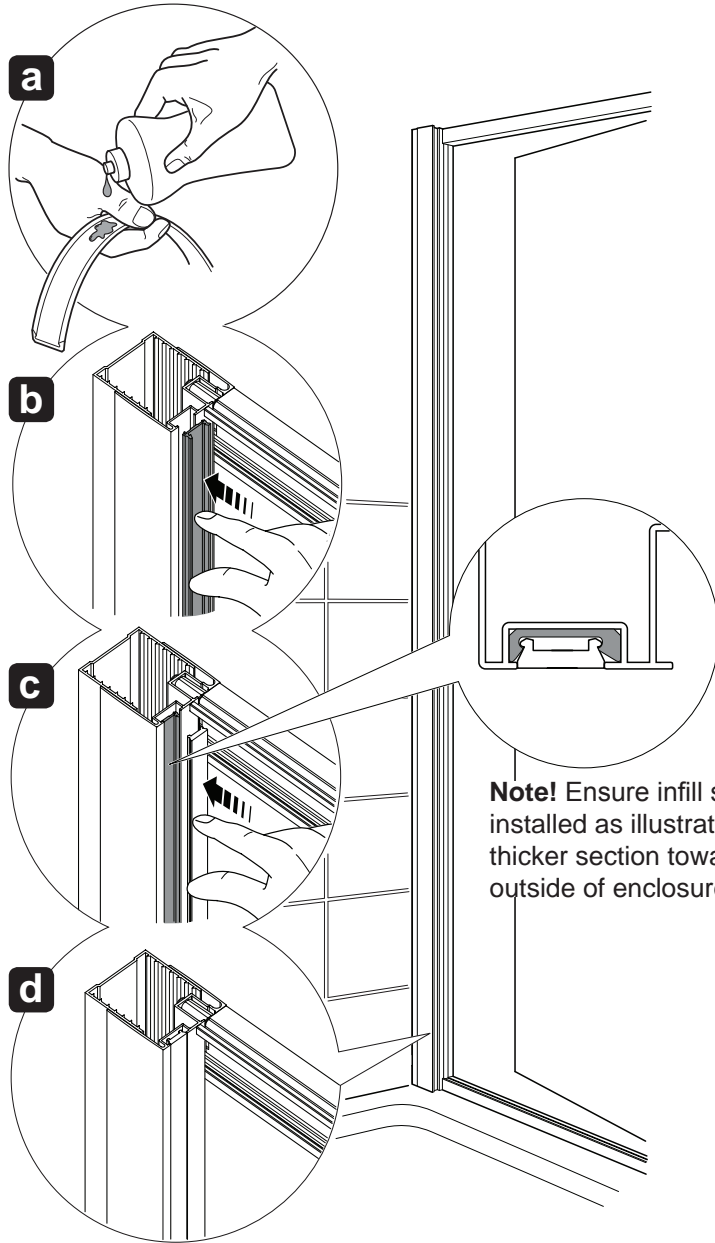

**Note!** Ensure infill strip is installed as illustrated with thicker section towards outside of enclosure.

- (a) Lubricate the rubber strip with washing up liquid or a suitable lubricant to help aid installation.
- (b) Install the rubber strip as shown above to both sides, working from top to bottom.
- (c) Install the infill strip.

14

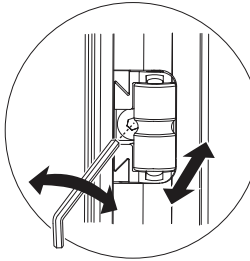

2.0 mm

(a) If necessary, adjust the door catch as shown above.

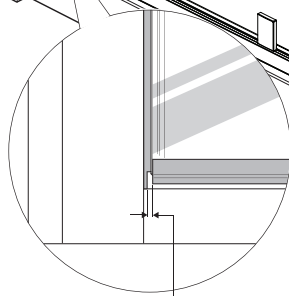
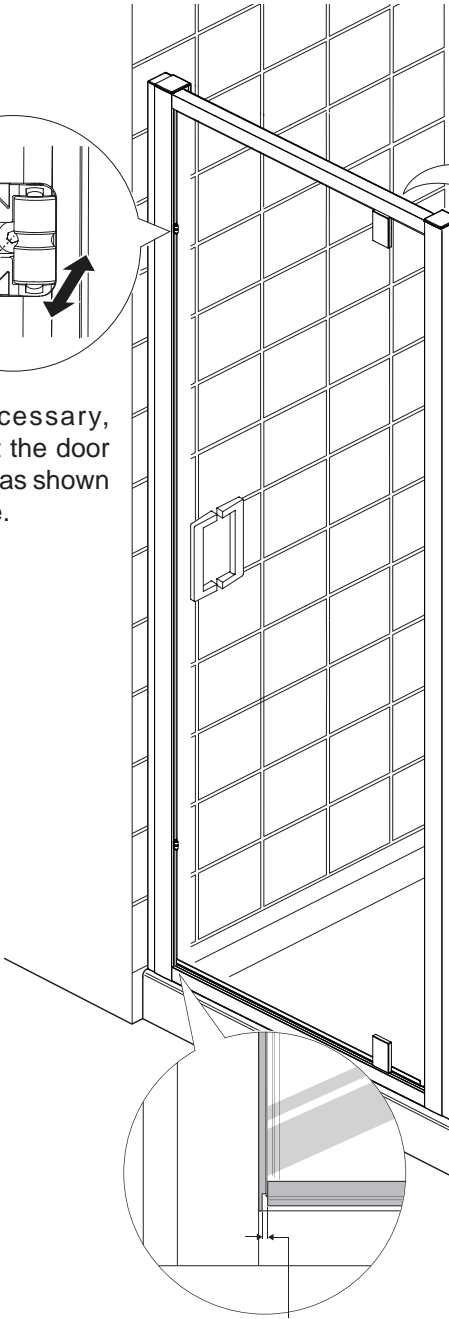

**Note!** Adjust door to minimise seal gap

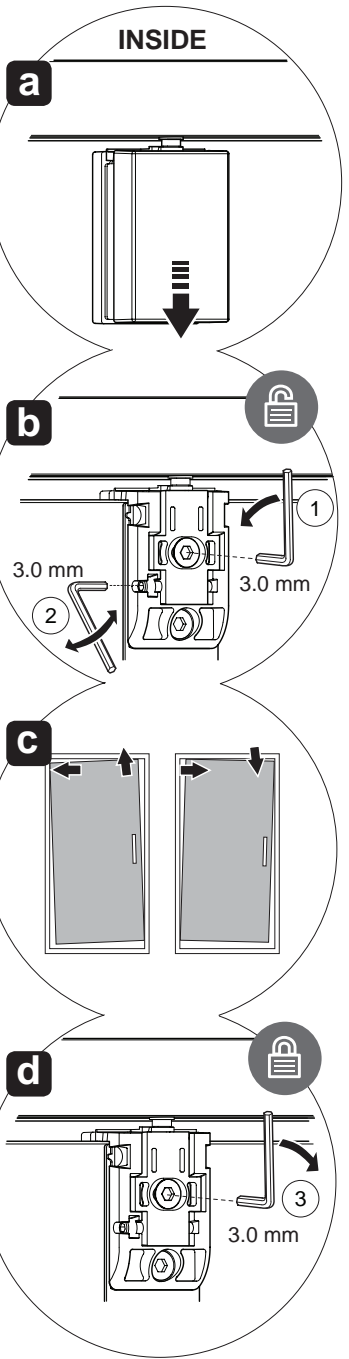

(b) If the door is out of square, adjust as shown above.

15

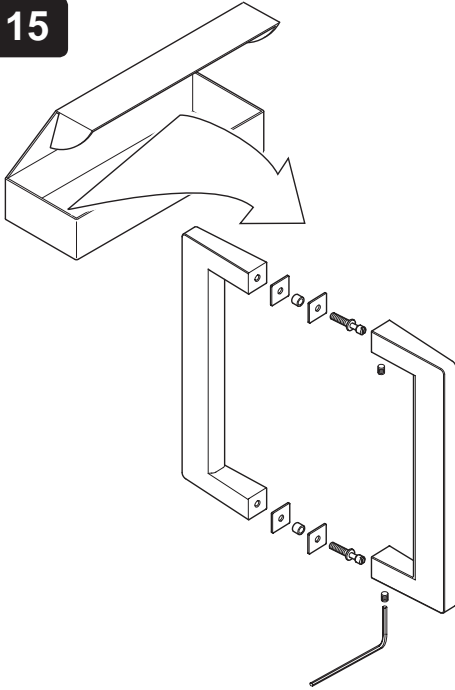

16

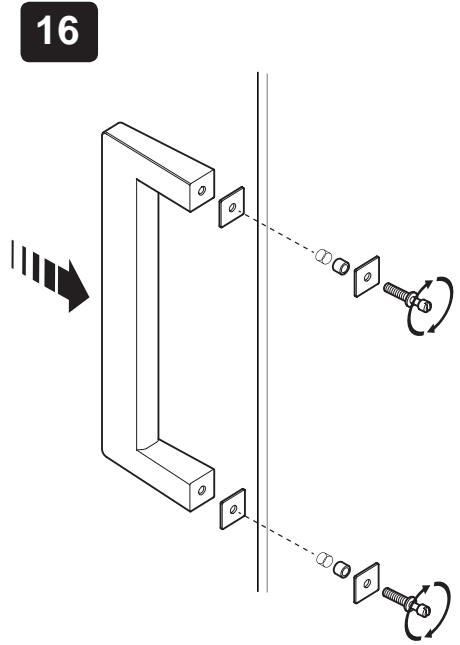

17

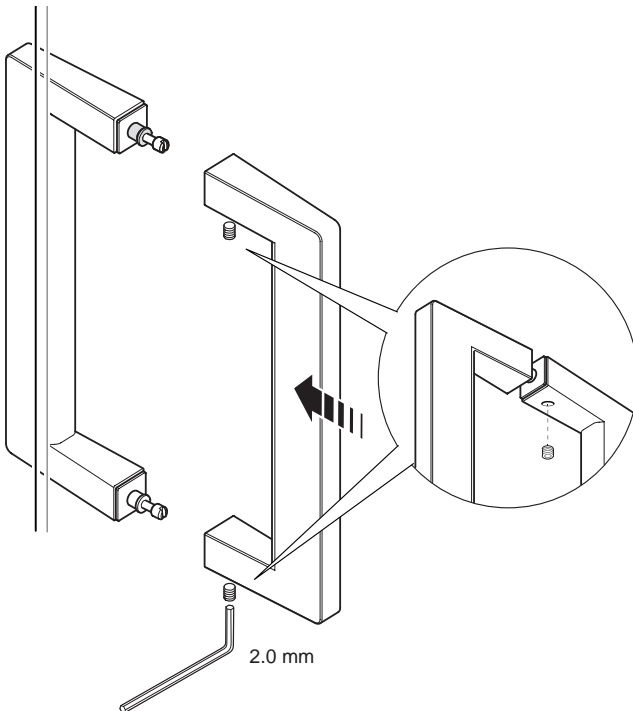

18

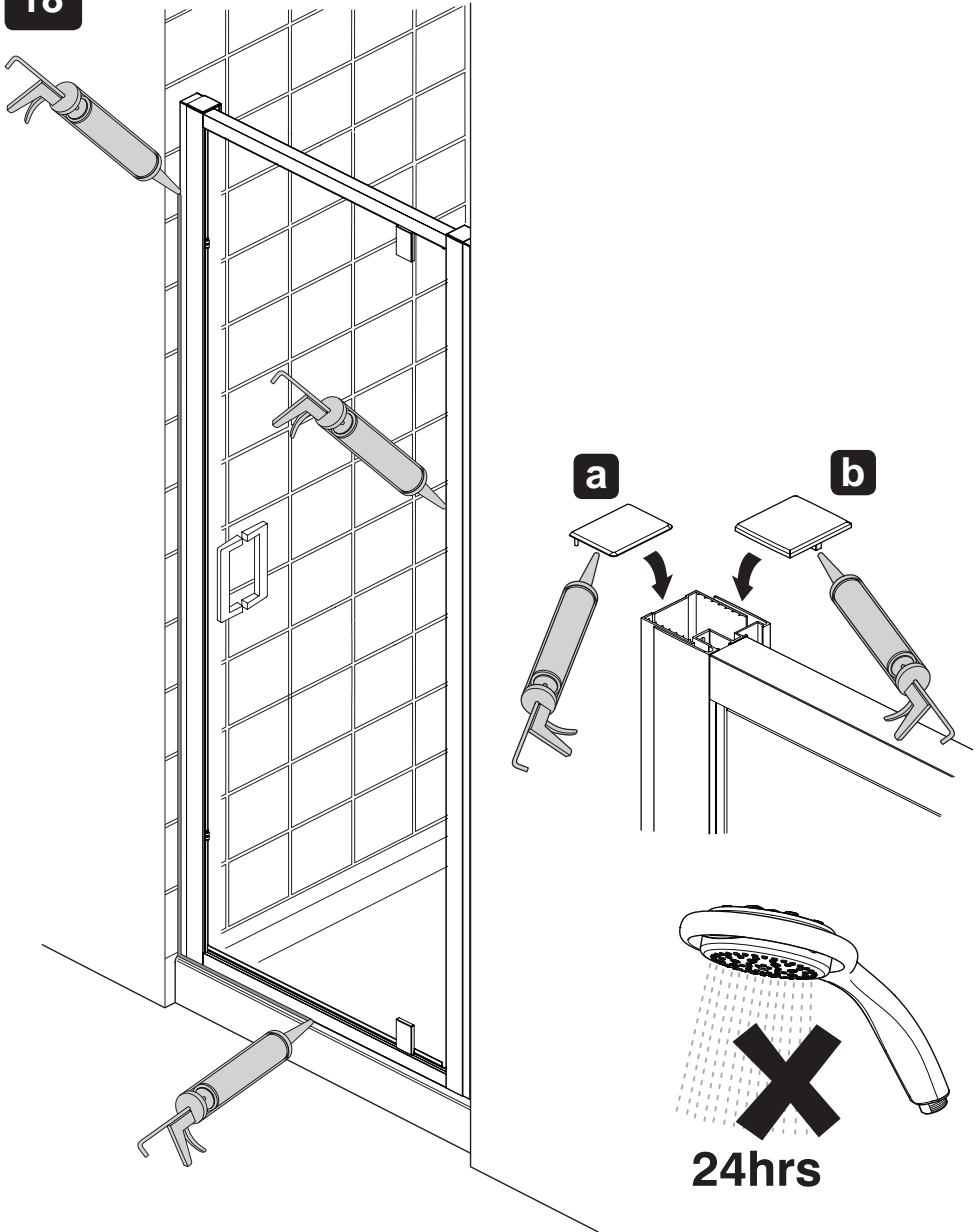

- (a) Apply sealant in accordance with the sealant manufacturers instructions along the outside surfaces of the door frame only.
- (b) Allow the silicone sealant to cure for 24 hours before use.
- (c) Fit the plastic covers to the top of the extrusions.

# MAINTENANCE

## General Maintenance

Providing the shower enclosure has been correctly installed and is operated in accordance with the instructions contained in this guide, difficulties should not arise. If any maintenance is required then it must be carried out by a competent tradesperson to whom the maintenance instructions are provided.

Before replacing any parts ensure the underlying cause of the malfunction has been resolved.

## Cleaning

**Warning!** The use of grout/tile cleaners, scale removers, abrasive scourers, drain unblockers and other powerful detergents may lead to damage of metallic, plated and plastic surfaces, including the tray and shower waste.

Avoid the use of 'spray and leave' cleaners. Any cleaner used should have a pH level between 4 and 8 and immediately wiped dry using a soft cloth.

## Care

To preserve the beauty of your shower enclosure for many years, please observe the following care instructions:

Rinse glass and frame with clear water after showering. Remove water droplets with a squeegee. **Do not rub dry!** To clean your shower hygienically and easily, we recommend the use of a biodegradable cleanser.

Regular cleansing with a biodegradable cleanser prevents stubborn stains and ensures a clean and hygienic surface for many years. Do not use scouring or caustic cleansers under any circumstances! These can damage the surface of the frame, glass and decorative parts as well as the plastic parts.

## Chrome Parts

Use only cleansers expressly specified for chrome!

## KOHLER Glass Cleaner

For occasional cleaning of glass treated with KOHLER Glass Protector or for more regular maintenance of untreated surfaces, we recommend using KOHLER Glass Cleaner.

The cleaner cleans and polishes without smearing or streaking and rejuvenates the Glass Protector.

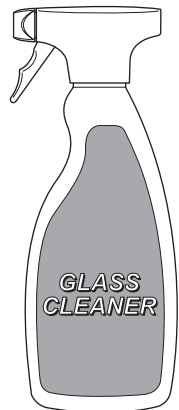

# SPARE PARTS

760, 800, 900 Pivot Door

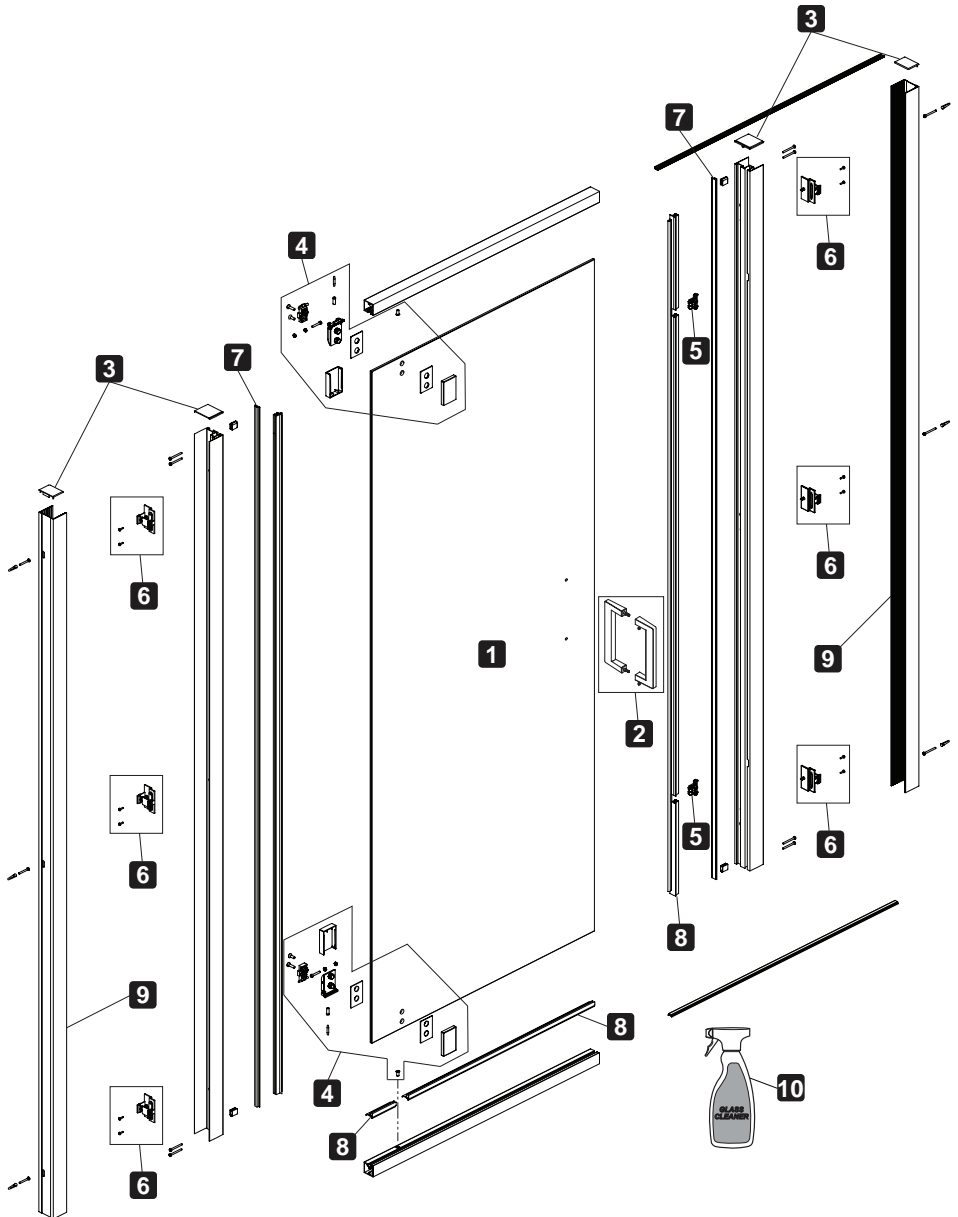

**760, 800, 900 Pivot Door**

1	1781.375	Pivot Door Glass Spare 760
	1781.385	Pivot Door Glass Spare 800
	1781.386	Pivot Door Glass Spare 900
2	1857.284	Handle Spare
3	1781.377	Door Top Cap Pack
4	1781.378	Hinge Spare
5	1781.379	Ball Catch Spare
6	1781.380	Locking Mechanism Spare
7	1781.381	Infill Spare
8	1781.382	Seal Kit Pivot Door
9	1781.427	Wall Channel Spare
10	305818	Glass Cleaner



# 1000, 1200 Pivot Door

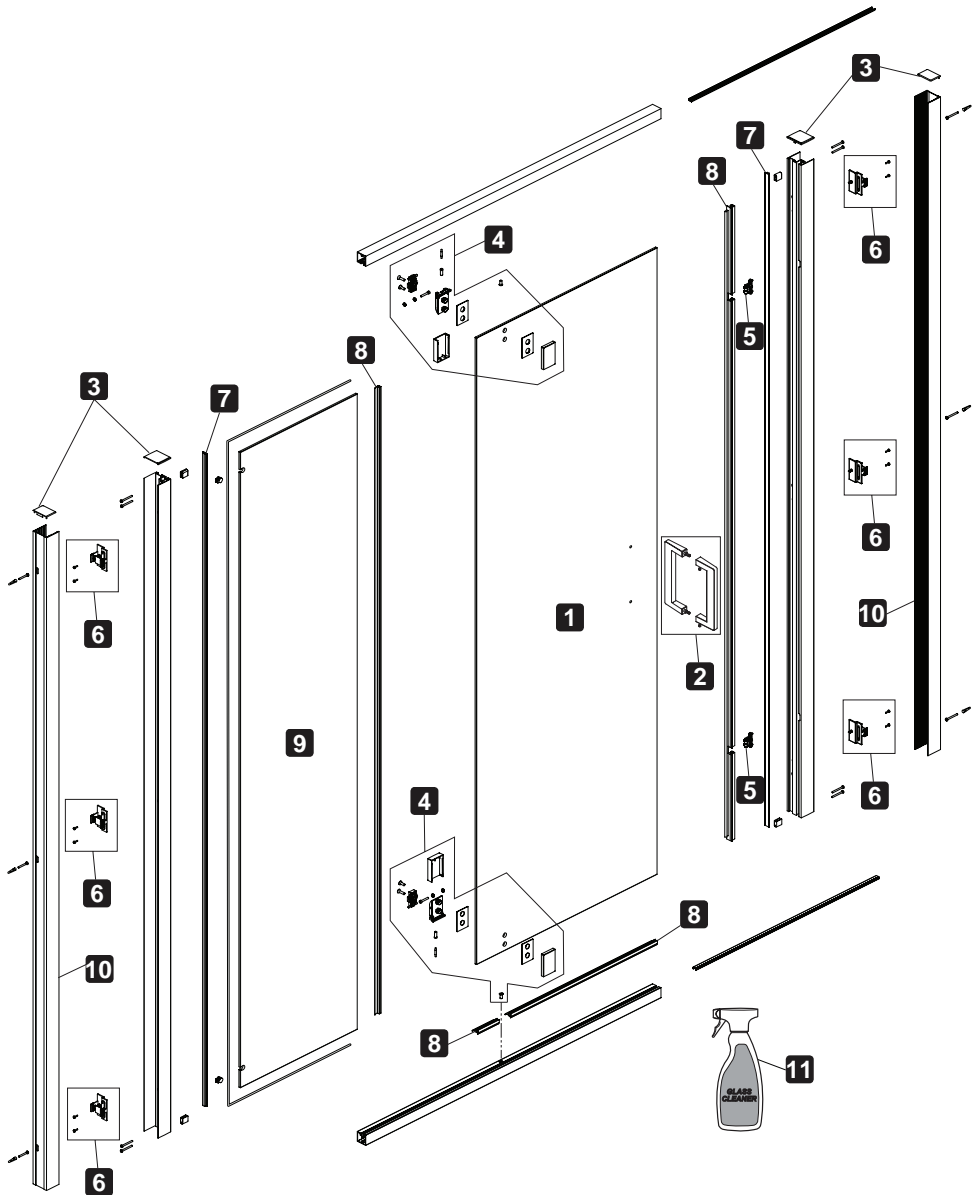

**1000, 1200 Pivot Door**

1	1781.385	Pivot Door Glass Spare 1000, 1200
2	1857.284	Handle Spare
3	1781.377	Door Top Cap Pack
4	1781.378	Hinge Spare
5	1781.379	Ball Catch Spare
6	1781.380	Locking Mechanism Spare
7	1781.381	Infill Spare
8	1857.283	Seal Kit Pivot Inline
9	1781.384	Pivot Panel Glass Spare 1000
	1781.387	Pivot Panel Glass Spare 1200
10	1781.427	Wall Channel Spare
11	305818	Glass Cleaner

# DECLARATION OF PERFORMANCE

## DECLARATION OF PERFORMANCE

**Brand name:** Mira

**Product name:** Leap Shower Enclosures

**Product Range:** Leap Pivot Door, Leap Sliding Door, Leap Quadrant Enclosure, Leap Walk in Enclosure, Leap Extended Sliding Door  
Leap Bi-Fold Door, Leap Side Panel, Leap Pentagon Enclosure, Leap Double Door Slider

**Product type:** Domestic Shower Enclosure

**Manufacturer:** Kohler Mira Ltd  
Cromwell Road, Cheltenham  
Gloucestershire GL52 5EP  
United Kingdom.

**Directives:** EU 305/2011 Construction Products Regulations

**System of assessment:** System 4:  
Type testing / Factory production Control

**Standards:** EN 14428:2004 +A1:2008.  
Shower enclosures – Functional requirements and test methods.

Essential Characteristics	Performance	Harmonised technical specification
IR-CA-DA	Compliant	EN 14428:2004 +A1:2008

The performance of the products described above, are in conformity with the relevant community harmonisation legislation.

This declaration of performance is issued under the sole responsibility of Kohler Mira Ltd.

Signed for and on behalf of Kohler Mira Ltd.

**Signature:**

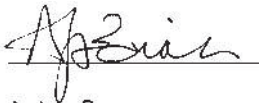

**Name:** Andrew Baines  
**Place:** Cheltenham, UK  
**Doc. No.:** CE 0099

**Position:** NPD Director  
**Date:** 1<sup>st</sup> September 2014  
**Issue:** 1.



# CUSTOMER SERVICE

## Guarantee

Your enclosure has the benefit of our lifetime guarantee which starts from the date of purchase. This guarantee only applies in the United Kingdom and the Republic of Ireland.

To activate this guarantee, you must return your completed registration card with a copy of proof of purchase from an approved Mira retailer within 30 days of purchase.

**This guarantee is in addition to your statutory rights and is subject to conditions (see registration card).**

## What to do if something goes wrong

If your product does not function correctly when you first use it, contact your installer to check that it is installed in accordance with the instructions in this manual.

If this does not resolve the issue, contact our Customer Services Team who will offer you or your installer help and advice.



### Helpdesk Service

Our Customer Services Team is comprehensively trained and can offer help and advice, spare parts, accessories or a service visit.

We will need you to have your model name, model number and date of purchase.



### Mira Showers Website ([www.mirashowers.co.uk](http://www.mirashowers.co.uk))

From our website you can register your guarantee, download additional user guides, diagnose faults, purchase our full range of accessories and popular spares, refer to our FAQ's and request a service visit.



### Spares and Accessories

We hold the largest stocks of genuine Mira spares and accessories.

Contact us for a price and to purchase spares or accessories (Only available in the United Kingdom).



### Service / Repairs

No one knows our products better than our nationwide team of Service Technicians. We can carry out service or repair work to your product both during and after the guarantee period (Only available in the United Kingdom and the Republic of Ireland).

Ask about our fixed price service repairs.

## To Contact Us: UK



**0844 571 5000**

Please note: Calls cost 7p per minute plus your phone company's access charge.



**01242 282595**



Email - Visit

[www.mirashowers.co.uk/contactus](http://www.mirashowers.co.uk/contactus)



By Post:

**Mira Customer Services Dept, Cromwell Road, Cheltenham, Gloucestershire, GL52 5EP**

## To Contact Us: Eire Only



**01 531 9337**



Email -

[CustomerServiceEire@mirashowers.com](mailto:CustomerServiceEire@mirashowers.com)

**CE 14**

Kohler Mira Ltd, Cromwell Road, Cheltenham, Gloucestershire GL52 5EP, UK.

### Mira

#### Leap Range of Domestic Shower Enclosures.

#### Declaration of Performance: CE 0099

Pivot Door, Bi-Fold Door, Sliding Door, Side Panel, Quadrant Enclosure, Pentagon Enclosure, Walk in Enclosure, Double Door Slider, Extended Sliding Door.

Essential Characteristics	Performance	Specification
IR,CA,DA	Compliant	EN 14428:2004 +A1:2008



5 013181 077070 >

Mira is a registered trade mark of Kohler Mira Limited.

The company reserves the right to alter product specifications without notice.

**mira**  
SHOWERS

## **Check out our full range of Shower Enclosures**

Quadrant Shower Enclosures

Corner Entry Shower Enclosures

Walk in Shower Enclosures

Sliding Shower Doors

Bifold Shower Doors

Pivot Shower Doors

Hinged Shower Doors

Shower Screens

## **From Top Brands**

Coram Shower Enclosures

Mira Shower Enclosures

Hydrolux Shower Enclosures

Diamond Shower Enclosures

## **With quality shower trays to match your enclosure**

Square Shower Trays

Rectangular Shower Trays

Quadrant Shower Trays

Coram Shower Trays

Mira Flight Shower Trays

**plumbworld**  
**Big brands, small prices.**