

Mira Flight Low Level Shower Tray

Installation and User Guide

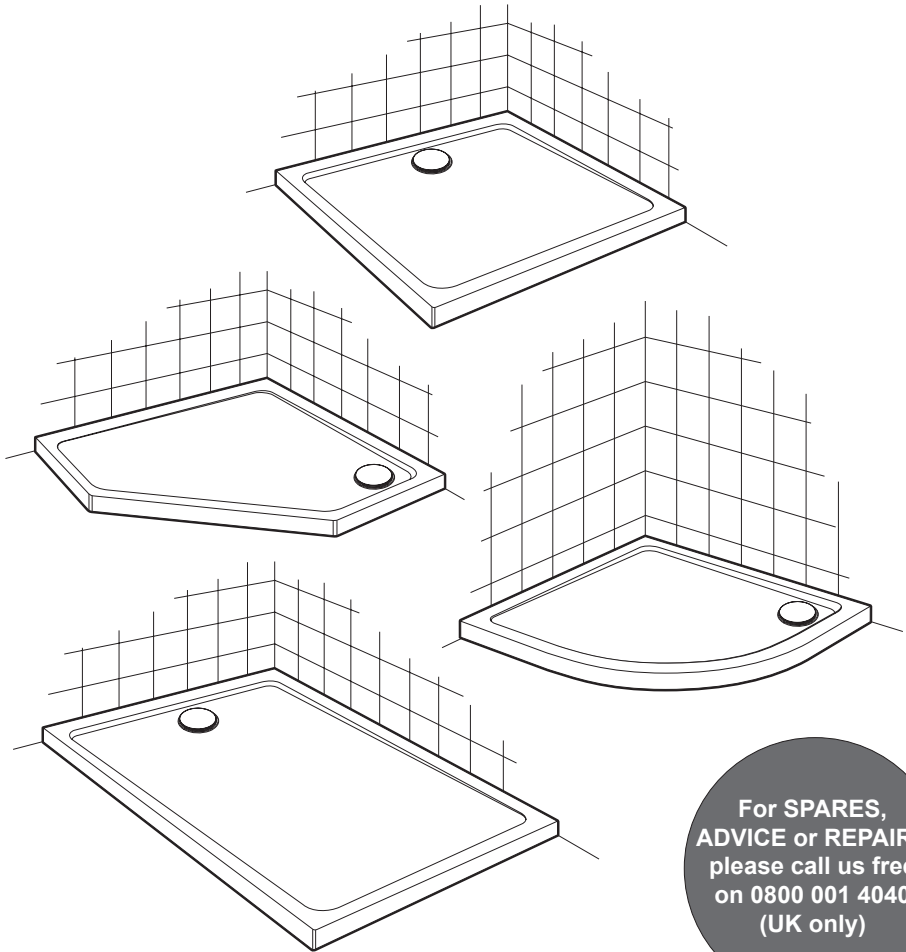

For SPARES,
ADVICE or REPAIRS
please call us free
on 0800 001 4040
(UK only)

These instructions must be left with the user

Please keep these details safe as you will need them when registering your product guarantee. Your guarantee information is included in this guide.

mira
SHOWERS

Introduction

Thank you for purchasing a quality Mira product. To enjoy the full potential of your new product, please take time to read this guide thoroughly, having done so, keep it handy for future reference. The following pages aim to provide comprehensive installation instructions, plus advice on how to care and maintain your product. We recommend that the unit is installed by a qualified plumber or engineer.

Please Read Important Information

1. **Store the product flat within its packaging until ready to install. DO NOT lean against the wall.**
2. **Ensure the tray is flat and level prior to install.**
3. Read all of these instructions and retain this guide for later use.
4. Pass on this guide in the event of change of ownership of the installation site.
5. Follow all warnings, cautions and instructions contained in this guide.
6. **Warning!** This product is a two man lift.
7. Before installation, carefully remove all of the protective film from the tray for inspection.
8. Carefully unpack and check the tray for colour, size, flatness, general acceptability and compatibility with the shower enclosure and other bathroom furniture.
9. Check for transit damage.
10. Report any faults immediately to your supplier. No claims will be considered after installation.
11. Fitting this product is acceptance of quality.
12. **Caution!** Additional protective coverings such as a dust sheet should be used to protect the tray from damage from falling objects during installation.
13. We recommend this tray is fitted as part of a fully enclosed cubical. If this tray is fitted as a walk-in installation, it is expected that an amount of water will spill onto the open area of the floor. We would therefore advise fixing a threshold strip to minimize this.
Note: Where the shower tray comes into contact with the wall or plaster board surface, apply a liberal amount of silicone sealant before installation. This will help secure the shower tray in position and reduce any rubbing of the surfaces.
14. Hand tighten the waste to ensure a correct seal. Excessive overtightening can lead to damage. **Caution! DO NOT** stand on waste outlet as damage may occur.
15. Once the waste pipe has been connected pour water into the tray to check the tray and pipe connection for correct drainage prior to final fix and tiling.

16. Excessive flow rates may lead to overflowing and leaking. Flow rate into the tray must not exceed flow rate of the shower waste. We recommend a drainage test is carried out to ensure the waste is adequate for the flow delivered.
17. The waste should be connected to 40 mm rigid waste pipe only, which must be installed to have a minimum fall of 18 mm per meter. The use of reducers or flexible waste pipes are not suitable for this product, and may lead to water build up in the tray and potential overflowing.
18. All legs supplied must be fitted. Make sure that all locking nuts are secured.
19. If you wish to raise the shower tray and not use the legs provided, please contact us for installation advice.
20. The shower tray should be positioned so that the waste is easily accessible for maintenance.
21. Water Spray may extend beyond the entrance of walk-in enclosures and we recommend tiling of the adjacent area.
22. **Caution!** Take care when showering. Wet Tray surfaces can increase the risk of slipping, particularly when soaps, shampoos and other bathing products are used.

Guarantee

Your product has the benefit of our manufacturer's 10 year guarantee (5 years for any commercial installations) which starts from the date of purchase.

Note: Wastes, upstand kits and riser kits are guaranteed for 1 year only. For terms and conditions refer to the back cover of this guide.

Patents

Patents:	European: 1667 562
----------	--------------------

Recommended Usage

Domestic	✓	Heavy Commercial	✗
Light Commercial	✓	Healthcare	✓

Notification to designers, installers and users:

The majority of all shower trays will show an increase in the potential for slipping, when the surface is wet. This is particularly the case when soap, shampoo, bath oil etc. are used. The Construction Products Directive (89/106/EEC)".

Dimensions

Rectangle Shower Tray - Non Upstand

Waste Assembly

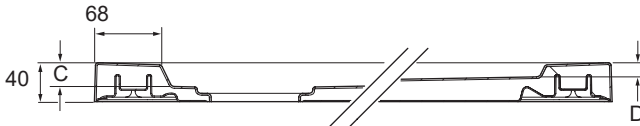
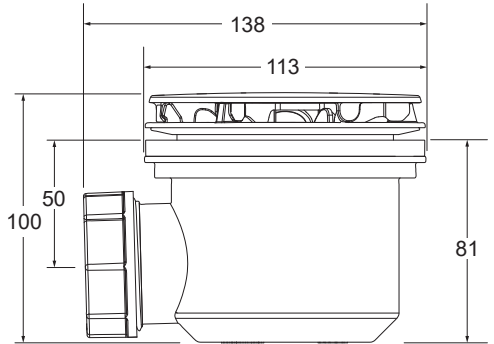
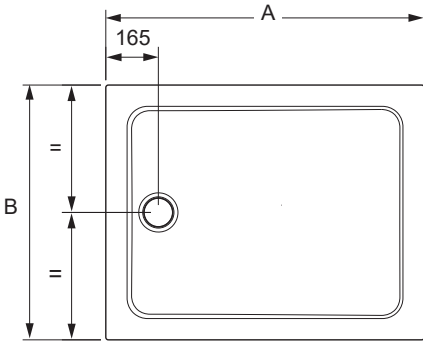

Side Profile of Non Upstand Tray

A	B	C	D	Legs
900	760	25	14	9
1000	700	25	12	9
1000	760	25	12	9
1000	800	25	12	9
1100	800	25	12	11
1200	700	25	9	11
1200	760	25	9	11
1200	800	25	9	11
1200	900	25	9	11
1400	700	25	5	13
1400	760	25	5	13
1400	800	25	5	13
1400	900	25	4	13
1500	700	24	3	13
1500	760	24	3	13
1600	700	24	4	13
1600	760	24	4	13
1600	900	24	4	13
1700	700	24	4	13
1700	760	24	4	13
1700	900	24	4	13

Square Shower Tray - Non Upstand

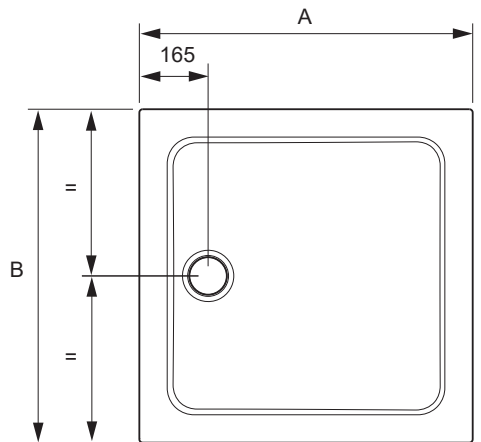

A	B	C	D	Legs
760	760	25	17	9
800	800	25	16	9
900	900	25	14	9
1000	1000	25	12	9

All Dimensions in mm

1493053-W2-B

Pentagon Shower Tray - Non Uprand

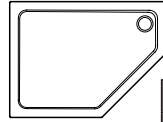
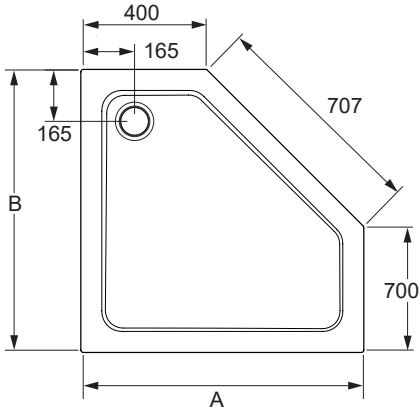

LH

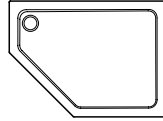

RH

A	B	C	D	Legs
900	900	25	14	9
900	1200	25	9	11

Quadrant Shower Tray - Non Uprand

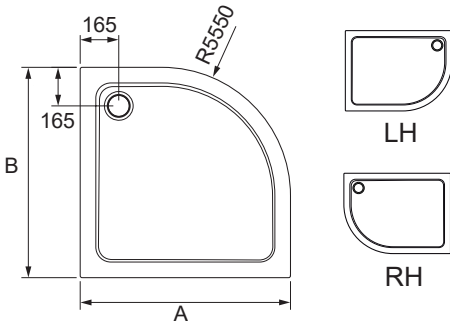

LH

RH

A	B	C	D	Legs
800	800	25	16	9
900	900	25	14	9
1000	1000	25	12	9
900	1200	25	9	11
1000	1000	25	12	9

Uprand Tray

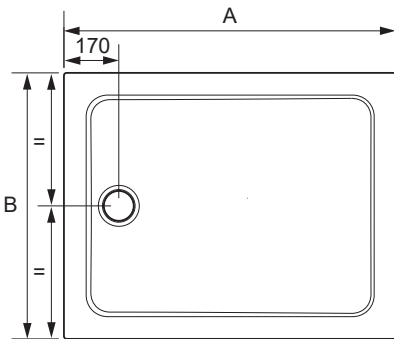

A	B	C	D	Legs
770	770	25	17	9
810	810	25	14	9
910	770	25	14	9
910	910	25	14	9
1010	810	25	12	9
1010	770	25	12	9
1210	770	25	9	11
1210	810	25	9	11
1210	910	25	9	11
1410	810	25	6	13
1410	910	25	6	13
1710	770	25	6	13
1710	910	25	6	13

Side Profile of Uprand Tray

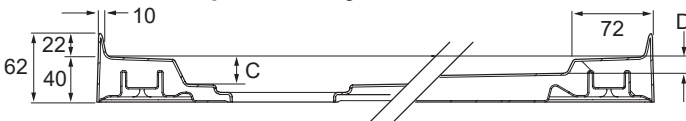

Rectangle Shower Tray - Corner Waste

Non Upstand				
A	B	C	D	Legs
1005	805	25	12	9
1205	765	25	9	11
1205	805	25	9	11
1405	805	25	5	13

Upstand				
A	B	C	D	Legs
1005	805	25	12	9
1205	765	25	9	11
1205	805	25	9	11
1405	805	25	6	13

All Dimensions in mm

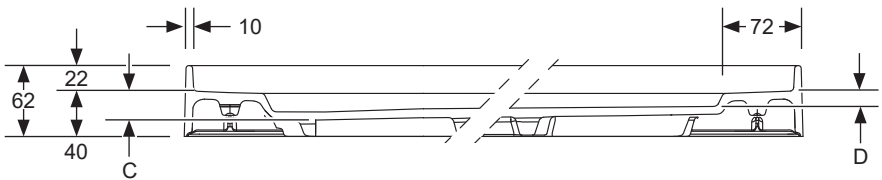
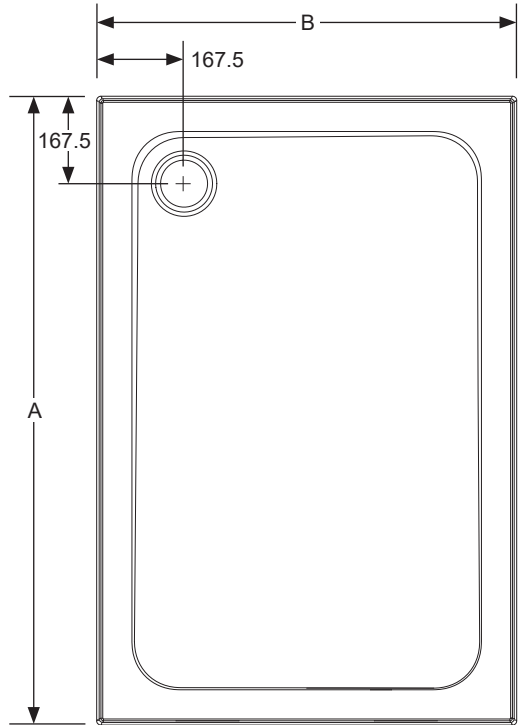

Side Profile of Upstand Tray

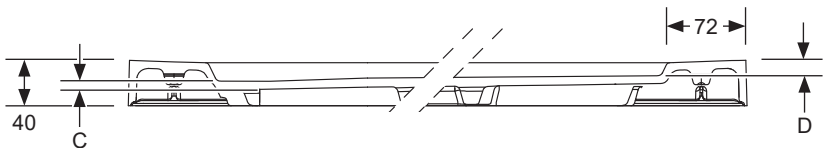

Side Profile of Non-Upstand Tray

Square Shower Tray - Corner Waste

Non Upstand				
A	B	C	D	Legs
765	765	25	17	9
805	805	25	16	9
905	905	25	14	9

Upstand				
A	B	C	D	Legs
765	765	25	17	9
805	805	25	14	9
905	905	25	14	9

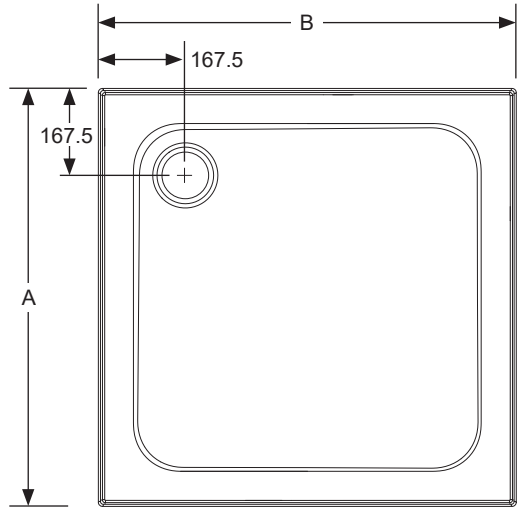

All Dimensions in mm

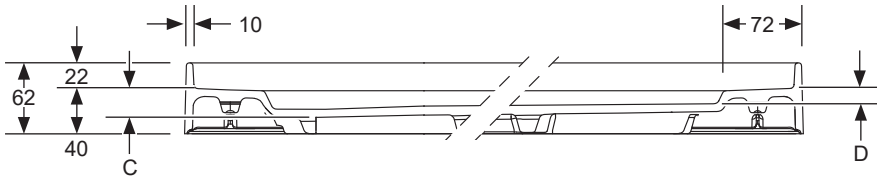

Side Profile of Upstand Tray

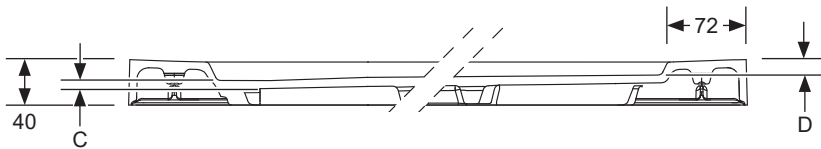

Side Profile of Non-Upstand Tray

Installation - Non Upstand Trays

1

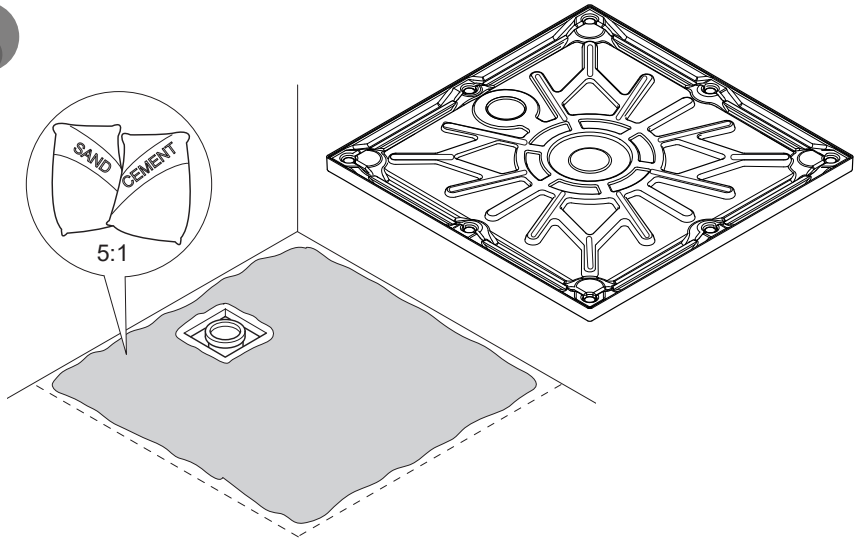

Install the shower tray on a bed of sand and cement.

2

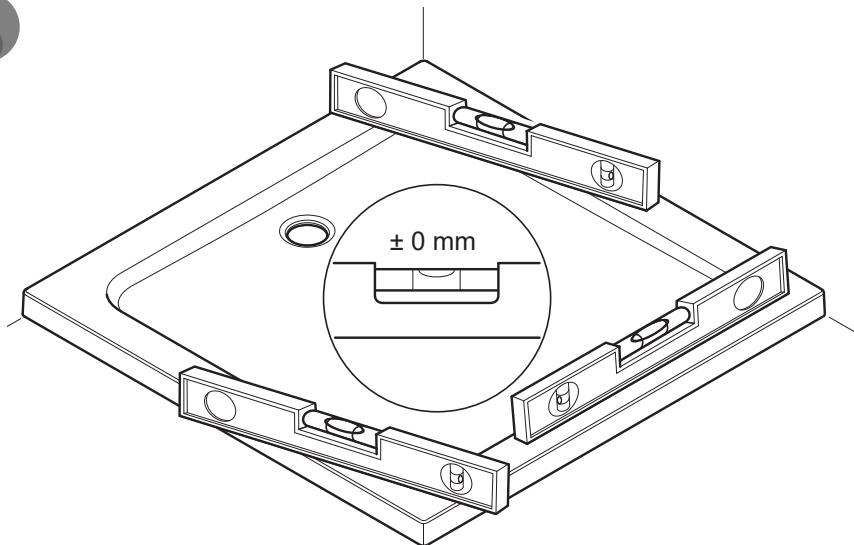

Place the shower tray on a flat surface and using a spirit level check that it is straight and flat and that the shower cubicle will sit on its surface correctly when fitted.

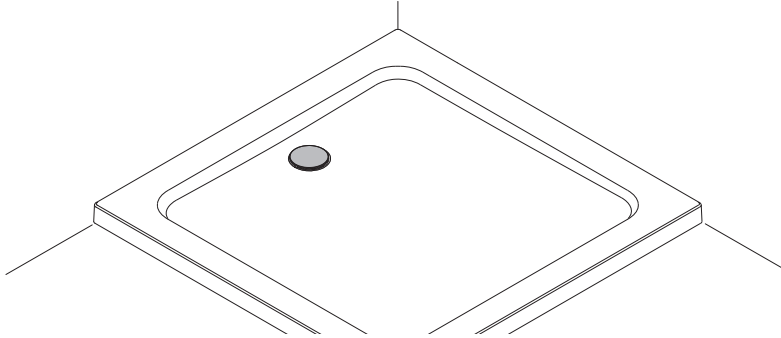
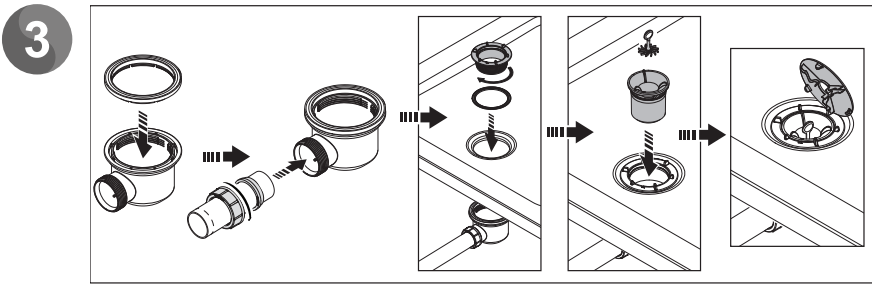

Install the waste. Refer page 11 for detailed instructions on how to install the waste.

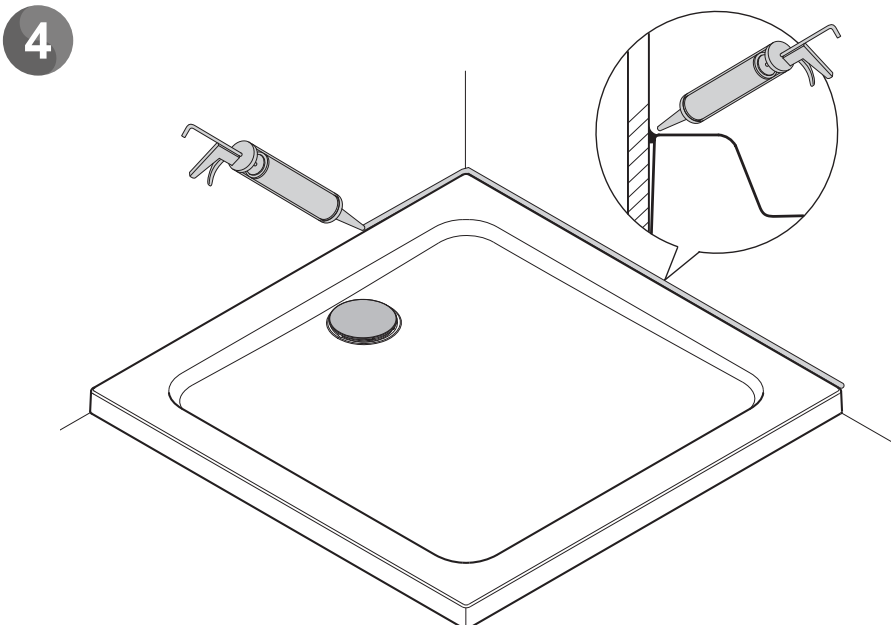

Apply silicone sealant where the tray meets the wall (in accordance with the manufacturer's instructions) to seal the shower tray to the wall.

5

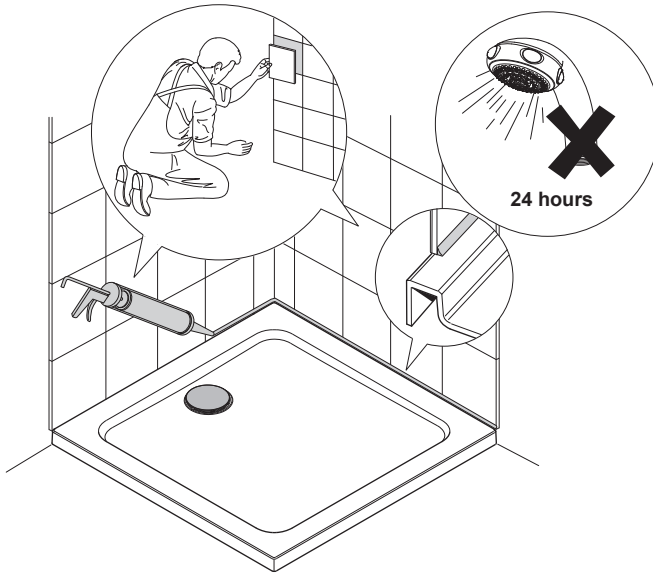

Tile the walls down on top of shower tray.

Apply silicone sealant (in accordance with the manufacturer's instructions) to seal the shower tray to the tiled wall surface.

Installation - Upstand Trays

1

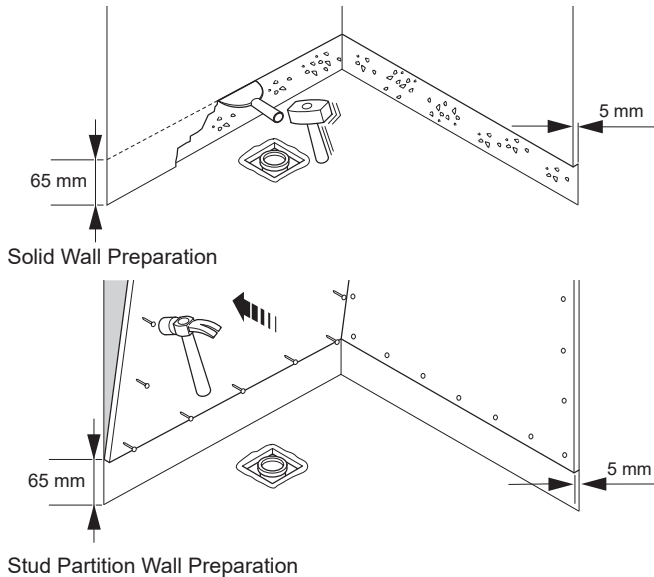

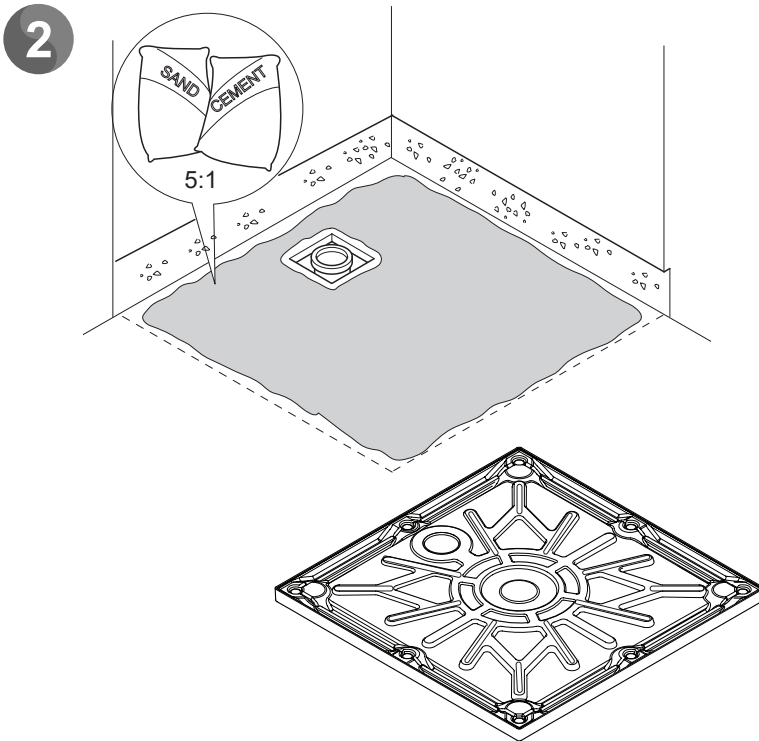

Install the shower tray on a bed of sand and cement.

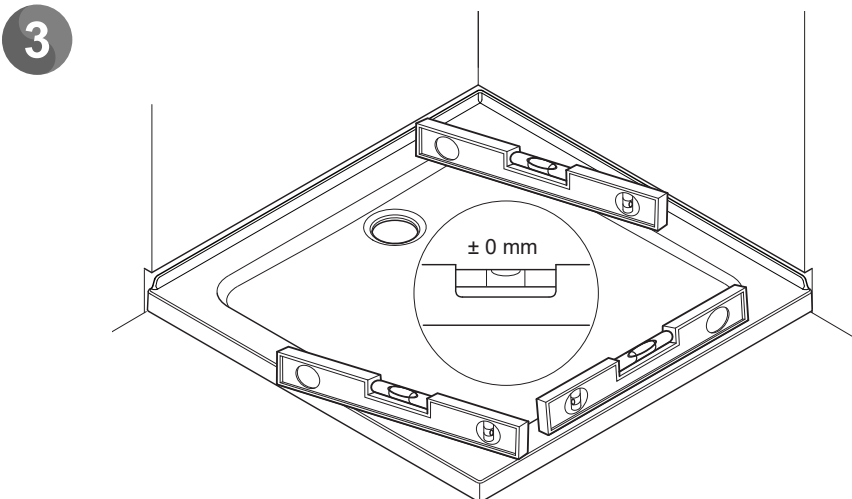

Place the shower tray on a flat surface and using a spirit level check that it is straight and flat and that the shower cubicle will sit on its surface correctly when fitted.

4

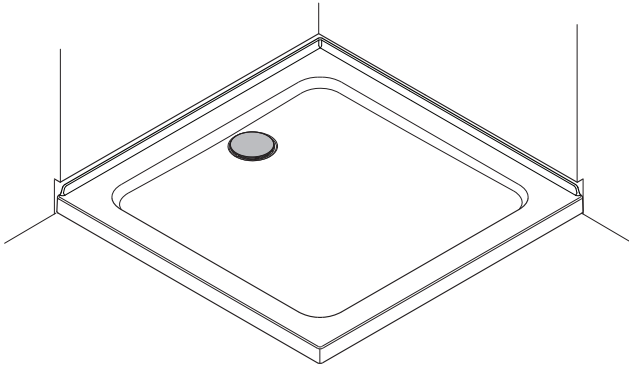
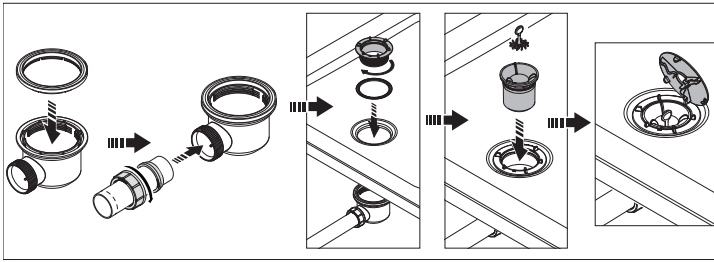

Install the waste. Refer next page for detailed instructions on how to install the waste.

5

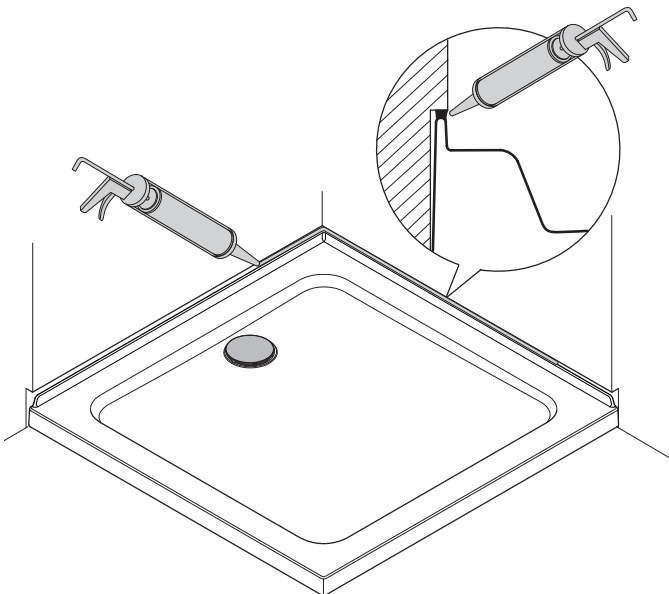

Apply silicone sealant where the tray meets the wall (in accordance with the manufacturer's instructions) to seal the shower tray to the wall.

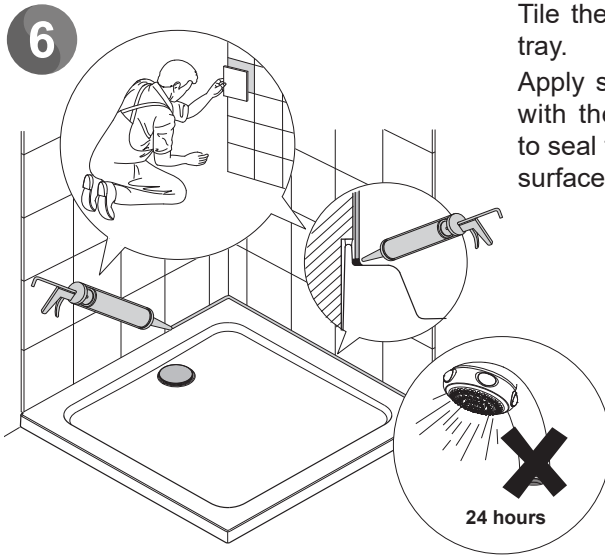

- 7** If you want to install your shower tray using a riser conversion kit, please refer to the Installation and User Guide packed with the riser kit.

Mira Rapi-Flo Waste Assembly Installation

1 Waste Parts Breakdown

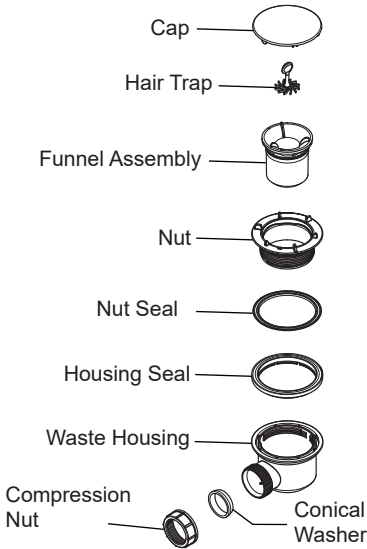

2

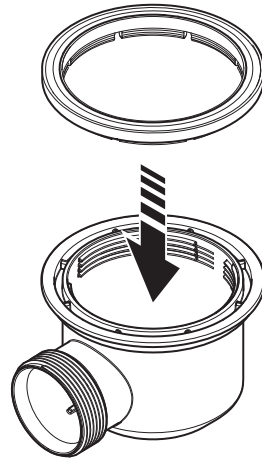

3

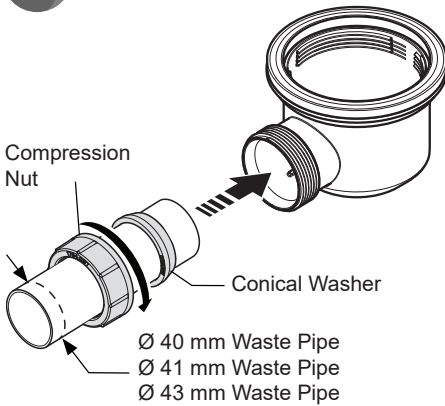

4

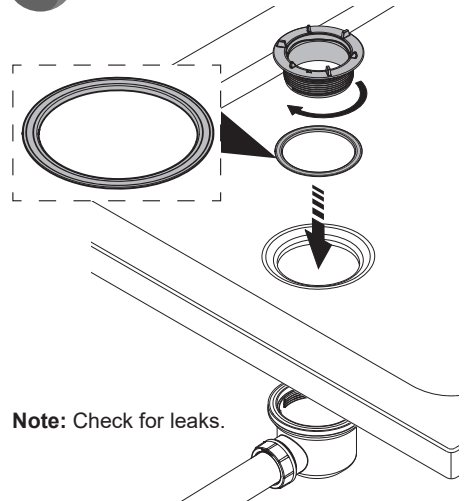

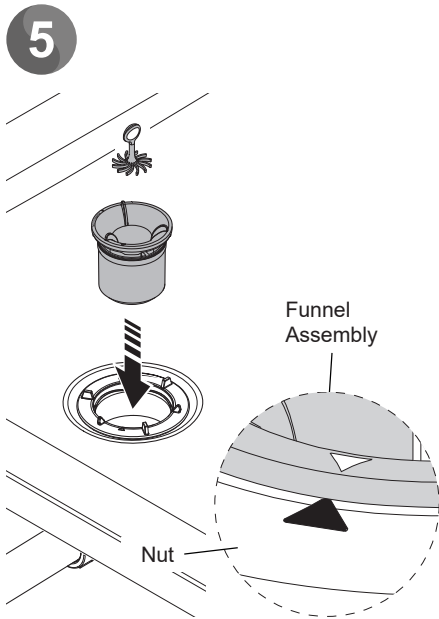

When fitting the funnel into the waste body, you **MUST** ensure the two arrows are aligned.

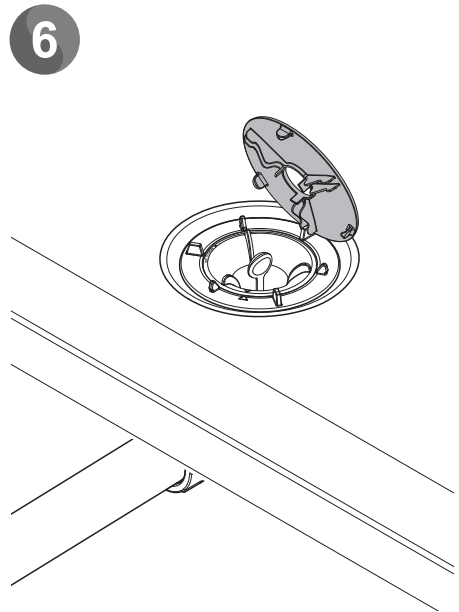

When fitting the waste cap, ensure the features are aligned as illustrated, the cap should click into place.

Care and Maintenance

Warning! The use of grout/tile cleaners, scale removers, abrasive scourers, drain unblockers and other powerful detergents may lead to damage of metallic, plated and plastic surfaces, including the tray and shower waste.

The acrylic/ABS surface of this shower tray has good resistance properties to acids but should not come into contact with alkalis or organic solvents, such as caustic soda, dry cleaning agents and paint strippers and strong acids. Should the shower tray be subjected to any non-approved substance it must be cleaned immediately. Particular care must be taken not to damage the manufacturing logo.

Only clean this shower tray with hot soapy water, the tray should be wiped dry with a lint free cloth.

Cleaners of gritty or abrasive nature should **never** be used.

Care should be taken when cleaning anti-slip surface.

Regular maintenance is essential to retain a high performance flow rate.

Kohler Mira cannot be held responsible for damage or the effects e.g. discoloration, caused by third party substances and / or materials such bath or shower mats.

Cleaning

Remove the hair trap and thoroughly clean under running water.

Occasionally it may be necessary to remove the funnel section for a more rigorous clean.

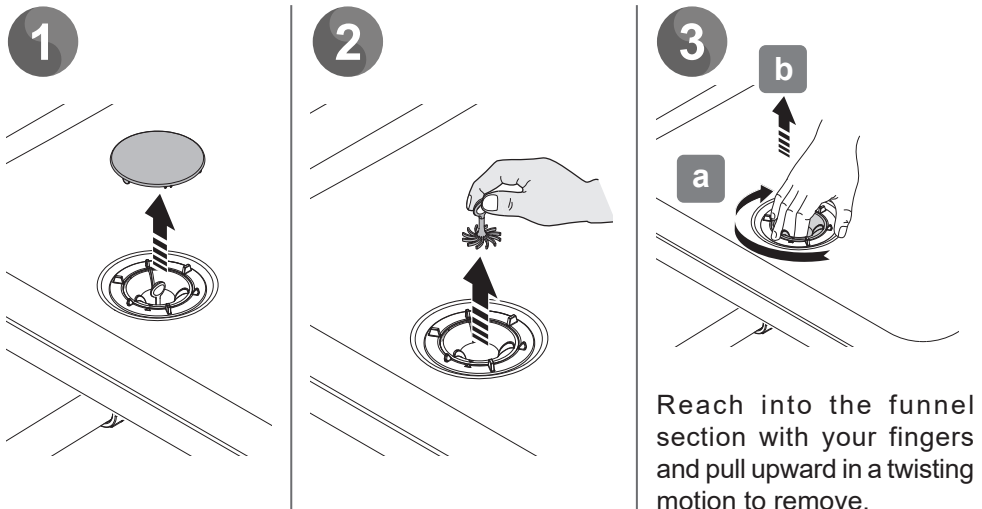



4

Clean the hair trap thoroughly under clean running water. Flush through the waste body with clean water.

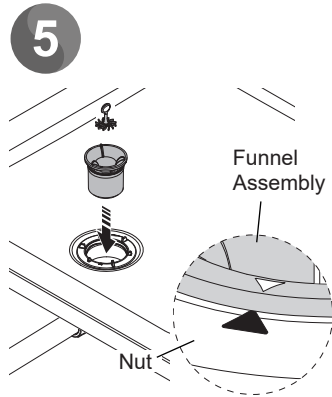

5

When fitting the funnel into the waste body, you **MUST** ensure the two arrows are aligned.

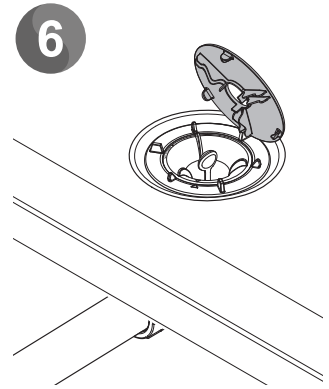

6

When fitting the waste cap, ensure the features are aligned as illustrated, the cap should click into place.

Spare Parts

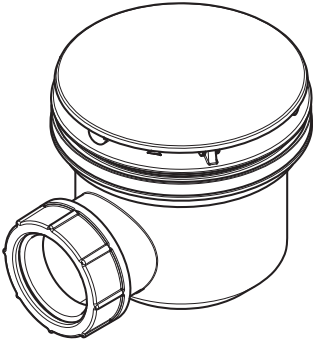

4.1970.009
Mira Rapi-Flo Waste Assembly
(Complete waste assembly, with
all parts & chrome waste cap)



4.1970.008
Hair Trap

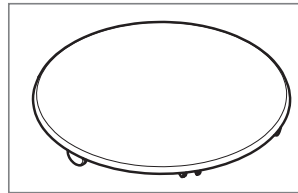

4.1970.007
Mira Rapi-Flo Waste Cap (Chrome)

Activate your Free* Guarantee

Thank you for choosing Mira. By registering your product, this will act as your proof of purchase and enable us to provide the best possible after sales service.

REGISTER NOW

Registering your guarantee is quick and simple. To ensure your product is covered, please register online.



Scan the QR code to activate your guarantee now or call 0800 5978551 within 30 days of purchase (UK only).

(You will need the Model Name, Product Code and Date of Manufacture. This information can be found on the front page of this guide)

* If you do not activate your guarantee proof of purchase will be required.

Mira has appointed Domestic & General Insurance PLC to provide product registration services and protection plans to accompany its products.

What we do with your information

At Domestic & General we want to reassure you that we use your information both responsibly and securely to provide you with the best possible service. Below we explain what we do with your information and your rights to your information. If you would like any further details you can get in touch with us using the contact details below or visit our website (www.domesticandgeneral.com).

Using your information

Domestic & General Insurance PLC ("we") is the "data controller" of your information. We process two sets of information about you, "Personal Information" (your name, address, contact and payment details) and the "Goods Information" you provide to register your appliance or device (your name, address, contact and goods details). We'll use your information:

(i) As necessary to fulfil our contract with you (including to recover any amounts owing); (ii) for our legitimate interests in: undertaking marketing (about our products and services and those of our third party partners) by post, telephone, email and/or other electronic messaging services; market research; customer surveys; printing services; checking and verifying your identity and contact details; recording your conversations for training, quality and compliance purposes; and for analytics and profiling for marketing purposes; and (iii) where required to do so by law. We may also ask for your consent to some uses of your information.

Sharing your information

From time to time your Personal Information and Goods Information may also be shared with other members of the Domestic & General Group of Companies (Domestic & General Insurance or Services and other future members of the Group whose details we will notify to you ("Group")), where applicable with Kohler Mira Limited which is the subject of your protection policy and with companies acting on our behalf or providing services to us (e.g. the companies we use to carry out repairs, IT & mailing services, storage of paper records and telecommunications). Kohler Mira Limited will process your Personal Information for their legitimate business interests (including marketing and analytics) in accordance with their privacy policy.

Transferring your information

In exceptional cases, we may transfer your information to countries outside the European Economic Area (including the US) which may not have data protection laws which provide the same level of protection as provided in the UK. We have put in place Model Clauses as an appropriate safeguard to ensure that such information is adequately secured and protected and that such transfers meet the requirements of applicable data protection law.

Keeping your information

We keep your Personal Information for six years after you terminate your policy so that we can deal with any claims. Your goods information we keep for a bit longer, normally 10 years (the average life of an appliance) for health and safety. We also keep your information to send you marketing that you might be interested in, unless we receive a request from you to opt-out of marketing.

Rights to your information

By writing to the Data Protection Officer using the contact details provided below, you have the right to ask us:

- For a copy of the Personal Information we hold about you
- For a copy of the Personal Information you provided to us to be sent to you or a third party in a commonly used, machine readable format
- To update or correct your Personal Information to keep it accurate
- To delete your Personal Information from our records if it is no longer needed for the original purpose; and
- To restrict the processing of your Personal Information in certain circumstances

And you may also:

- Object to us processing your Personal Information, in which case we will either agree to stop processing or explain why we're unable to, and
- Where we rely on your consent, withdraw that consent at any time

Please note that the above rights are not absolute and certain exemptions apply to them. You can also make a complaint to the Information Commissioner (www.ico.org.uk) if you feel your Personal Information has been mishandled.

Marketing

We, along with other members of our Group and Kohler Mira Limited may use your information to tell you about any offers, products or services which may be of interest to you. We may contact you by post, telephone, email and/or other electronic messaging services.

To change your marketing preference, let us know by emailing marketingpreferences@domesticandgeneral.com or by writing to us using the contact details provided below. For Kohler Mira Limited marketing you'll need to contact them directly using their contact details that you'll normally find in their privacy notice.

Contact Details

If you need to contact us about your information or your information rights, or to see a copy of our Model Clauses, please write to Freeport Plus RTKS-CLRA-GRYE, Data Protection Officer, Domestic & General, Leicester House, 17 Leicester Street, Bedworth CV12 8JP or dataprotection@domesticandgeneral.com and we'll be happy to help you.

Customer Service

Guarantee

Your product has the benefit of our manufacturer's guarantee which starts from the date of purchase. This guarantee only applies in the United Kingdom and Republic of Ireland.

Activating Your Guarantee

Registering your guarantee is quick and simple. To ensure your product is covered, please register online.



Scan the QR code to activate your guarantee now or call 0800 5978551 within 30 days of purchase (UK only).

What is Covered:

- The guarantee applies solely to the original installation under normal use.
- The product must be installed and maintained in accordance with the instructions given in this guide.
- Servicing must only be undertaken by us or our appointed representative.
- Repair under this guarantee does not extend the original expiry date. The guarantee on any replacement parts or product ends at the original expiry date.
- For shower fittings or consumable items we reserve the right to supply replacement parts only.

The guarantee does not cover:

- Call out charges for non product faults (such as damage or performance issues arising from incorrect installation, improper use, inappropriate cleaning, lack of maintenance, build up of limescale, frost damage, chemical attack, corrosion, system debris or blocked filters) or where no fault has been found with the product.
- Water or electrical supply, waste and isolation issues.
- Routine maintenance or replacement parts to comply with the requirements of Building / Plumbing / Electrical Standards or Schemes.
- Compensation for loss of use of the product or consequential or indirect loss of any kind.
- Damage or defects caused if the product is repaired or modified by persons not authorised by us or our appointed representative.
- Accidental or wilful damage.
- Products purchased ex-showroom display.
- Disinfection or descaling to reduce bacterial growth or contamination.

What to do if something goes wrong

If your product is not working correctly please refer to this manual for fault diagnosis and to check that it is installed and commissioned in accordance with our instructions. If this does not resolve the issue, our Customer Services team are here to help get you back up and running. To help us solve your problem quickly, please have your product name, power rating (if applicable) and date of purchase to hand.

Mira is a registered trade mark of Kohler Mira Limited.

The company reserves the right to alter product specifications without notice.

Registered Office:
Cromwell Road,
Cheltenham,
Gloucestershire
GL52 5EP

EU Importer address
K/E S.A.S.
3 rue de Brennus,
93631, La Plaine Saint-Denis,
France



mira
SHOWERS

Visit www.mirashowers.co.uk

Visit our website to register your guarantee, book a service visit, diagnose faults and purchase products.

Spares and Accessories

We stock a full range of spare parts and fittings and are all available to purchase either online or over the phone. Our online spare parts selector tool will help you quickly and easily identify the spare part for your product.

Visit www.mirashowers.co.uk/parts-accessories

Replacements and Repairs

In the unlikely event that your product needs a repair, our nationwide repairs and installation team are here to help. You can book a convenient date and time online.



Scan the QR code to book a service visit now or visit www.mirashowers.co.uk/support/repair-services/repair-service

We also offer a comprehensive replacement service for when your product needs a little refresh, visit our website or contact our team for more information on our replacement services.

Help us improve

Your experience is important to us and your review (whether good, bad or otherwise) will be posted on Trustpilot.com immediately to help other people make more informed decisions.

Visit uk.trustpilot.com/review/www.mirashowers.co.uk

CE 13

Kohler Mira Limited, Cromwell Road, Cheltenham,
Gloucestershire, GL52 5EP, UK

Mira
Flight Low Shower Tray
Declaration of Performance: CE 0069
EN 14527 - CL1 + CL2

If you need a copy of the Declaration of Performance, then please contact Customer Services.

Need to get in touch?

UK

T: 0800 001 4040
E: askus@mirashowers.com
www.mirashowers.co.uk

Eire

T: 01 531 9337
E: customerserviceire@mirashowers.com
www.mirashowers.ie