

Thermostatic bar shower with square shower column

Fitting instructions

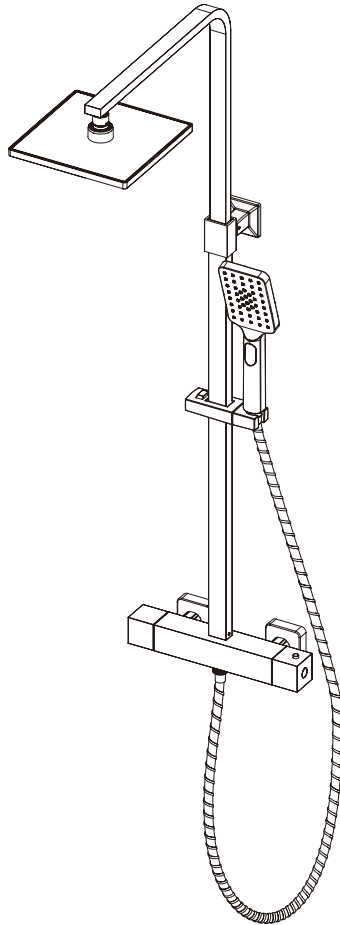

Please keep these instructions for future reference and request of replacement parts.

We have taken great care to ensure that this product reaches you in perfect condition. However should any parts be damaged or missing please contact your point of purchase. This does not affect your statutory rights. In addition if you require replacement parts your point of purchase will be happy to assist.

Contents	Page
1. General Information	2
2. Tools Required	3
3. Parts Supplied	3
4. Before You Start	4
5. Water Supply Temperature	4
6. Installation	5-7
7. Temperature Setting	8
8. Aftercare	9-10
9. Troubleshooting	11

General Information

This product complies with BS EN 1111.

This product must be fitted in compliance with the UK Water Supply (Water Fittings) Regulations. If in doubt please contact your local water authority.

Tools Required (Tools not supplied)

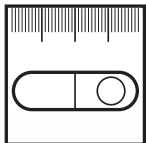
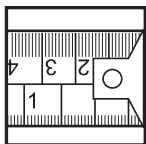
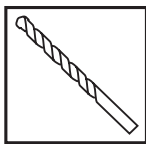
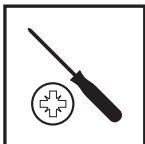

Parts Supplied

NO.	Description	Qty
1	Bar valve	1
2	Sealing washer	2
3	Flange	2
4	Eccentric unions	2
5	Slider	1
6	Grub screw	2
7	Shower tube	1
8	Shower head	1
9	Rail bracket	1
10	Fixing bracket	1
11	Wall Screw	1
12	Wall plugs	1
13	Handset	1
14	Shower hose	1
15	Hexagonal key	1

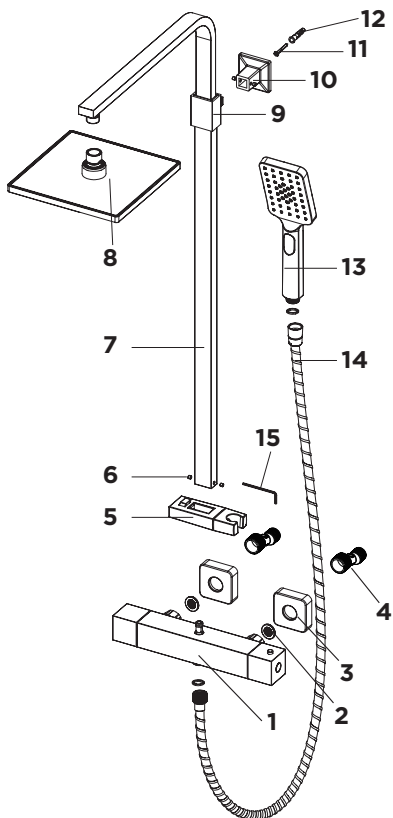

Before Your Start

BS 8558 recommends hot water should be stored and distributed at a temperature of not less than 60°C which will help minimise the build-up of limescale. For further details contact your Local Water Authority.

This shower should be installed in compliance with the UK Water Supply (Water Fittings) Regulations.

- (a) Identify all components and check pack contents.
- (b) Turn off water mains supply.

Water Supply Temperature:

Hot Water Maximum: 70°C	Recommended 60-65°C
Cold Water Minimum: 5°C	Recommended 10-15°C

Operating Pressure Range:

Minimum: 0.5 Bar
Maximum: 5.0 Bar

Always maintain a 10°C difference between hot system temperature and maximum hot setting of valve.

Hot and Cold Maximum pressure differential should be no more than 2 bars. If this limit is exceeded, fit a pressure reducing valve (not supplied).

Operating pressures on hot and cold lines should be kept as even as possible in order to ensure the maximum efficiency of the mixer.

When water pressure is higher than 5 bar a pressure reducing valve (not supplied) must be fitted before the mixer.

Flow restrictors(not supplied) can be fitted into the wall unions to reduce water consumption on high pressure system.

Installation

-Fitting the Thermostatic Shower Valve

1. Flush pipe work prior to installation to remove debris from the system.
2. Turn off water supply following system flushing.
3. Install the ½ inch section of the Eccentric union (4) to the supply pipes (the centres are 140-160mm) being sure to fit adequate seals (not supplied). Ensure that the Eccentric unions (4) on the same lever, the centre of the 2x Eccentric unions (4) are 150±1 mm.

Note: these Unions are not compression fittings.

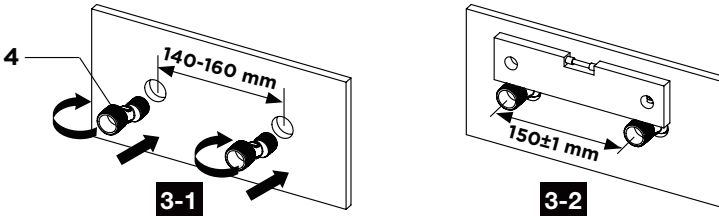

4. From the front, align the Eccentric Unions (4) with the Bar Valve (1) inlets. Screw Flange (3) to the ¾ inch section of the Eccentric Unions (4) protruding through the wall. Sealant can be used between the Flange (3) and the wall.

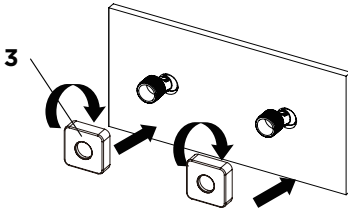

5. Install Bar Valve (1) with sealing washer (2) to the Eccentric Unions (4).

Note: the outlet of the bar valve to be downward, the cold inlet (indicated by a blue dot on the rear of the mixer) to the right. then tighten the nuts of the Bar Valve (1) until secure.

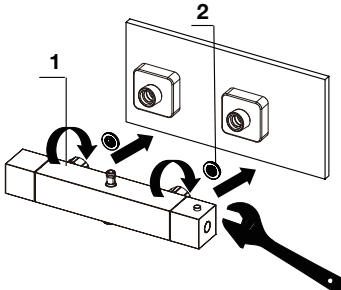

-Fitting the Shower Kit

1. Using a level, measure from the central point, vertical to 702mm and mark, as shown.
2. Drill and prepare fixings for the fixing bracket using the components supplied (if suitable).
3. Insert the wall plug(12), Secure the fixing bracket(10) using the supplied wall screw (11, if suitable). use the orientation of the fixing bracket(10) and the slotted fixing to allow for minor adjustments.

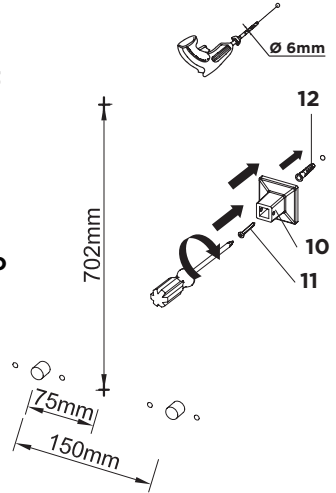

4. Gently press the button of the slider(5) and push it to shower tube(7).

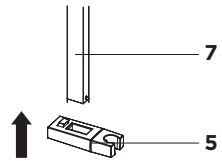

5. The telescopic section of the riser can adjust the height between 830-1130mm, loosen the grub screw on the rear of the rail bracket(9), adjust to the desired height and re-tighten the grub screw.

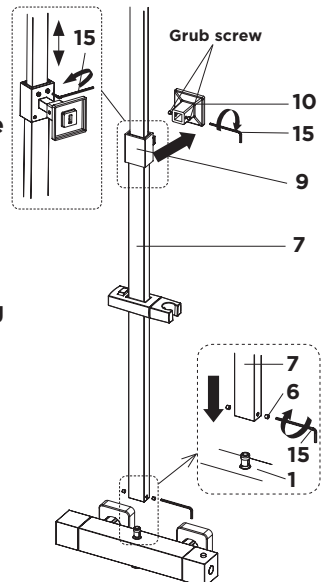

6. Position the shower tube(7) assembly on the bar valve outlet, tilt the shower tube(7) back and slot the rail bracket(9) in to the fixing bracket(10), hold in place by gently tightening the grub screws.

Note: You can minor adjust the fixing bracket to ensure the shower tube is level and tighten grub screws to secure.

7. Screw the grub screw(6) to shower tube and tighten. Take care not to damage the surface of the bar valve. Do not over tighten.

8. Tighten the fixing nuts of the shower tube using a suitable tool, taking care not to overtighten.

9. Turn on water supplies and check for leaks.

10. Ensuring the hose washer is in position, attach the non-conical end of the shower hose(14) to the bar valve. Run the shower for a few seconds to clear any debris that may be present. Then attach the conical end of the shower hose(14) to the handset(13), then place the hose in the slider.

11. Ensure the hose washer is in place, screw the shower head(8) on to the arm, taking care not to damage the plated surface. Tighten carefully using a suitable tool taking care not to overtighten.

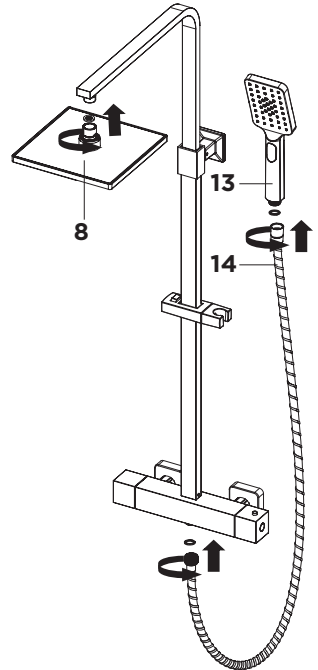

Temperature Setting (To be done only when essential)

This mixer has been set in the factory under balanced pressures and hot water supply at 65°C.

When your operating conditions vary significantly from the above, the temperature of the mixed water may vary from the setting. In this case, you can set the temperature of the mixer to suit your requirements.

The valve is set to a maximum 46°C. This can be checked if required using a thermometer. If this temperature is incorrect, you can reset it as the following:

1. Turn the handle to 38°C position.
2. Remove handle cap, then the handle screw, then the temperature handle.
3. Without removing the black stop, turn the spindle of thermostatic valve until the temperature is at the required level.
4. Test again using a thermometer.
5. When the required temperature is reached, re-fit the components, so that the chrome button stop will be at your new set temperature.

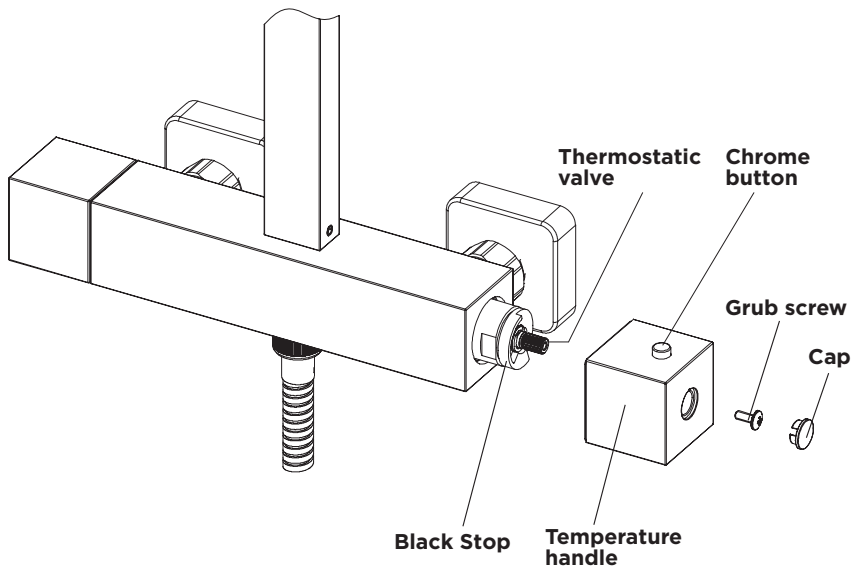

Aftercare

Cleaning the thermostatic cartridge

1. Before carrying out any maintenance, turn off the mains water supply. If you are unsure contact a qualified plumber.
2. Remove the cap, grub screw, temperature handle.
3. Pull the Black Stop from the cartridge. Remove the retaining nut using a suitable spanner, remove and clean the thermostatic cartridge rinse thoroughly under cold water to remove any build up of limescale or debris.
Note: take note of the position of the Black Stop and cartridge, they must be re-fitted in the same position.
4. Replace the cartridge into the body, tighten the retaining nut using a suitable spanner.
5. Re-fit the Black Stop, temperature handle, tighten the grub screw and re-fit cap to handle.

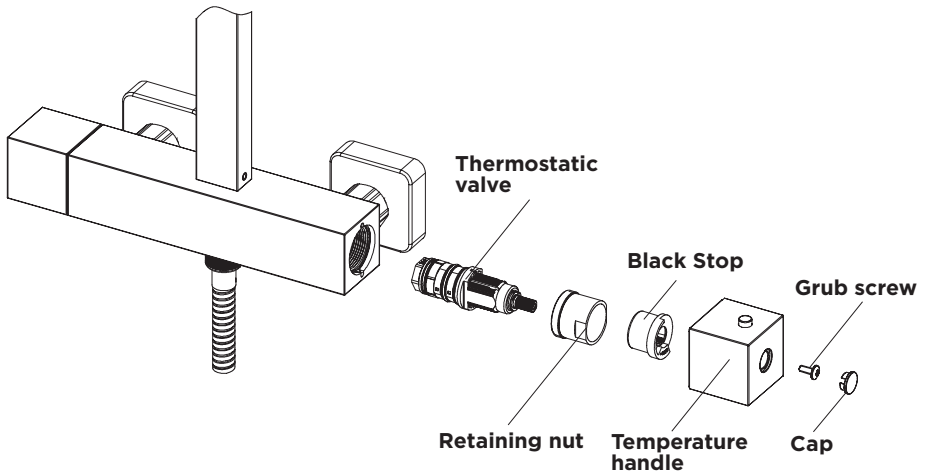

Cleaning the flow cartridge

1. Before carrying out any maintenance, turn off the mains water supply. If you are unsure contact a qualified plumber.
2. Remove the cap, grub screw, flow handle,
3. Remove the retaining nut using a suitable spanner, clean the diverter rinse thoroughly under cold water to remove any build up of limescale or debris.
4. If necessary replace the diverter.
5. Re-fit the diverter into the body, tighten the retaining nut using a suitable spanner.
6. Re-fit the flow handle, tighten the grub screw and re-fit cap to handle.

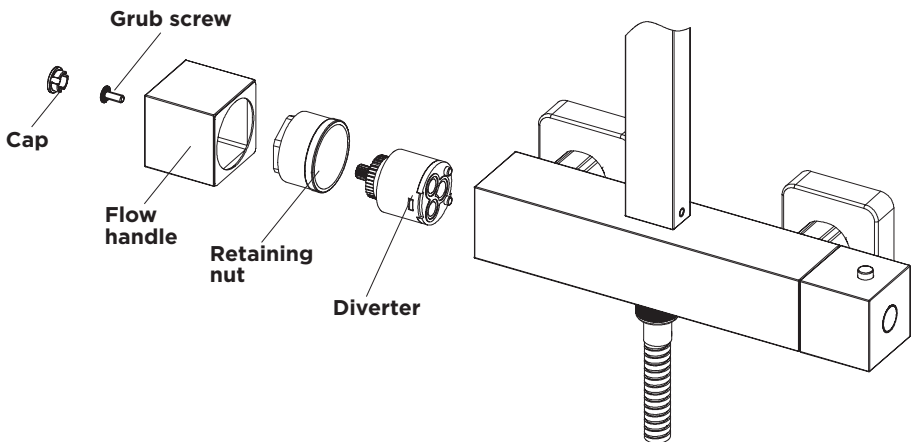

General Cleaning

Whilst modern plating techniques are used in the manufacture of these fittings, the plating will wear if not cleaned properly. The safest way to clean your product is to wipe with a soft damp cloth. Stains can be removed using washing up liquid. All cleaning powders and liquids will damage the surface of your fitting even the non-scratch cleaners.

Troubleshooting

Symptom	Cause	Remedy
No flow or low flow rate and /or varying temperatures.	Check showerhead, hose and filters for any blockage.	Clean as necessary. Refer to Aftercare section (page 9-10).
	Partially closed stop or service valve in water supply pipework to the shower valve.	Open stop or service valve.
	Instantaneous water heater cycles on and off as the flow rate or pressure is too low.	Increase water flow rate or pressure through system. Contact the boiler manufacturer.
	Head of water is below the minimum distance required.	Raise the cistern or fit a shower booster pump.
	Inlet filter is partially blocked.	Clean or replace, flush through pipework before refitting.
	Hot or cold water being drawn off elsewhere causing pressure changes or instantaneous boiler temperature changes.	Do not use other water outlets when using the shower.
	Make sure the maintained inlet pressures are nominally balanced and sufficient.	Refer to Water Supply Temperature (page 4).
	Airlock or partial blockage of the pipework.	Flush through pipework to ensure removal of debris and any airlocks.
	No hot or cold water reaching the shower valve.	Check hot and cold feeds (the valve will shut down if either the hot or cold supply fails).
Only hot or cold water from the shower valve outlet.	Partially closed stop or service valve in water supply pipework to the shower valve.	Open stop or service valve.
	Inlet filter is partially blocked.	Clean or replace, flush through pipework before refitting.
	Inlet water supplies are reversed (hot to cold supply).	Check the connections are the correct way round. Hot on the left and cold on the right when viewed from the front. Rework pipework as necessary.
Water leaking from showerhead.	This is normal for a short time after turning off.	Adjust angle of showerhead in holder as necessary to vary draining time.
	Shower flow valve failing to close fully, possibly due to water borne debris.	Remove flow valve and check. Refer to Aftercare section (page 9-10) before dismantling shower valve.
Maximum water temperature too hot or cold.	Maximum water temperature set incorrectly.	Reset maximum water temperature. Refer to Temperature setting (page 8).
Outlet water temperature too hot / cold.	Inlet filter is partially blocked.	Check inlet filters for any blockages and clean as necessary.
	Installation conditions outside operating parameters.	Refer to Water Supply Temperature (page 4). Refer to Aftercare section (page 9-10). Refer to Temperature setting (page 8).
Water temperature too cold Maximum water temperature incorrectly set.	Hot water temperature is less than 10°C above the required blend temperature.	Adjust hot water temperature or wait for water to reheat if stored system is used.
	Instantaneous water heater not igniting because water flow rate is too low.	Increase water flow rate through the system. Check inlet filters and clean or replace. Refer to Aftercare section (page 9-10). Contact the boiler manufacturer.