

DE	Gebrauchsanleitung / Montageanleitung	2
FR	Mode d'emploi / Instructions de montage	3
EN	Instructions for use / assembly instructions	4
IT	Istruzioni per l'uso / Istruzioni per l'installazione	5
ES	Modo de empleo / Instrucciones de montaje	6
NL	Gebruiksaanwijzing / Handleiding	7
DK	Brugsanvisning / Monteringsvejledning	8
PT	Instruções para uso / Manual de Instalação	9
PL	Instrukcja obsługi / Instrukcja montażu	10
CS	Návod k použití / Montážní návod	11
SK	Návod na použitie / Montážny návod	12
ZH	用户手册 / 组装说明	13
RU	Руководство пользователя / Инструкция по монтажу	14
FI	Käyttöohje / Asennusohje	15
SV	Bruksanvisning / Monteringsanvisning	16
LT	Vartotojo instrukcija / Montavimo instrukcijos	17
HR	Upute za uporabu / Uputstva za instalaciju	18
TR	Kullanım kılavuzu / Montaj kılavuzu	19
RO	Manual de utilizare / Instrucțiuni de montare	20
EL	Οδηγίες χρήσης / Οδηγία συναρμολόγησης	21
SL	Navodilo za uporabo / Navodila za montažo	22
ET	Kasutusjuhend / Paigaldusjuhend	23
LV	Lietošanas pamācība / Montāžas instrukcija	24
SR	Uputstvo za upotrebu / Uputstvo za montažu	25
NO	Bruksanvisning / Montasjeveiledning	26
BG	Инструкция за употреба / Ръководство за монтаж	27
SQ	Udhëzuesi i përdorimit / Udhëzime rreth montimit	28
AR	دليل الاستخدام / تعليمات التجميع	29
HU	Használati útmutató / Szerelési útmutató	30
JP	取扱説明書 / 施工説明書	31

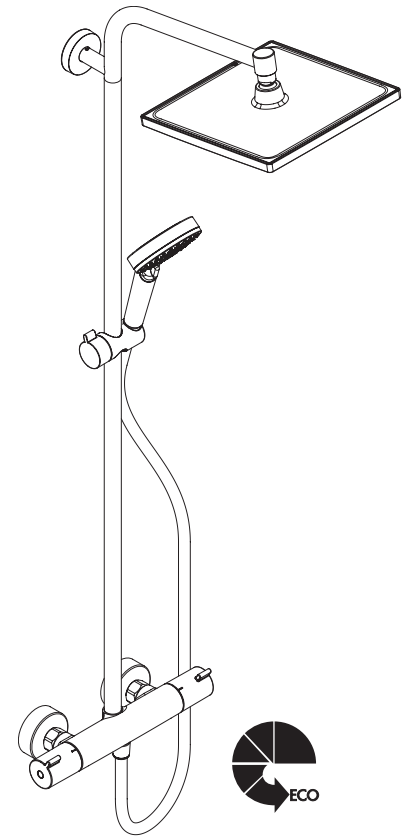

Crometta E 240 1jet Showerpipe EcoSmart
27281XXX / 26596000

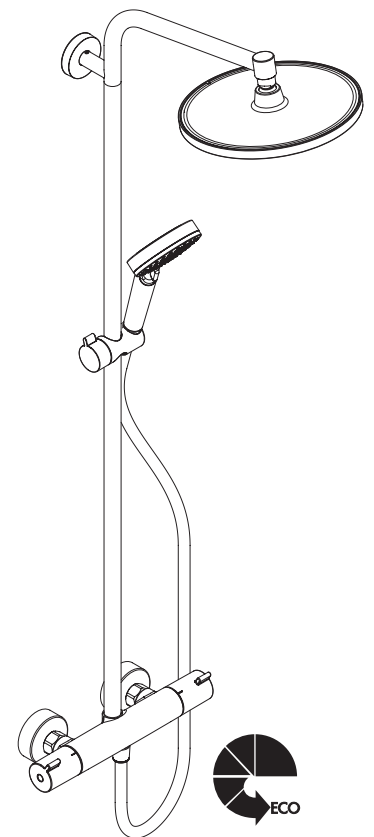

Crometta S 240 1jet Showerpipe EcoSmart
27268XXX



Sicherheitshinweise

- ⚠ Bei der Montage müssen zur Vermeidung von Quetsch- und Schnittverletzungen Handschuhe getragen werden.
- ⚠ Der Kopfbrausearm ist nur für das Halten der Kopfbrause ausgelegt, er darf nicht mit weiteren Gegenständen belastet werden!
- ⚠ Kinder, sowie Erwachsene mit körperlichen, geistigen und / oder sensorischen Einschränkungen dürfen das Produkt nicht unbeaufsichtigt benutzen. Personen, die unter Alkohol- oder Drogeneinfluss stehen, dürfen das Produkt nicht benutzen.
- ⚠ Der Kontakt der Brausestrahlen mit empfindlichen Körperstellen (z. B. Augen) muss vermieden werden. Es muss ein ausreichender Abstand zwischen Brause und Körper eingehalten werden.
- ⚠ Das Produkt darf nicht als Haltegriff benutzt werden. Es muss ein separater Haltegriff montiert werden.
- ⚠ Das Produkt darf nur zu Bade-, Hygiene- und Körperreinigungszwecken eingesetzt werden.
- ⚠ Große Druckunterschiede zwischen den Kalt- und Warmwasseranschlüssen müssen ausgeglichen werden.

Montagehinweise

- Vor der Montage muss das Produkt auf Transportschäden untersucht werden. Nach dem Einbau werden keine Transport- oder Oberflächenschäden anerkannt.
- Die Leitungen und die Armatur müssen nach den gültigen Normen montiert, gespült und geprüft werden.
- Die in den Ländern jeweils gültigen Installationsrichtlinien sind einzuhalten.
- Die in der Montageanleitung angegebenen Montagemaße sind ideal für Personen von ca. 1800 mm Körpergröße und müssen gegebenenfalls angepasst werden. Hierbei ist darauf zu achten, dass sich bei geänderter Montagehöhe die Mindesthöhe ändert und die Änderung der Anschlussmaße berücksichtigt werden müssen.
- Bei der Montage des Produktes durch qualifiziertes Fachpersonal ist darauf zu achten, dass die Befestigungsfläche im gesamten Bereich der Befestigung plan ist (keine vorstehenden Fugen oder Fliesenversatz), der Wandaufbau für eine Montage des Produktes geeignet ist und keine Schwachstellen aufweist.
- Die beige packte Siebdichtung muss eingebaut werden, um Schmutzeinspülungen aus dem Leitungsnetz zu vermeiden. Schmutzeinspülungen können die Funktion beeinträchtigen und/oder zu Beschädigungen an Funktionsteilen der Brause führen, für hieraus ergebende Schäden haftet Hansgrohe nicht.
- Das Produkt ist nicht für die Verwendung in Verbindung mit einem Dampfbad vorgesehen!
- Im Notfall kann das Rohr zwischen Armatur und Kopfbrause im unteren Bereich mit einer feinen Säge gekürzt werden.
- Bei Problemen mit dem Durchlauferhitzer oder großen Druckunterschieden muss die beige packte Drossel (Artikelnummer 97510000) in den Kaltwasserzulauf eingesetzt werden.

Technische Daten

Betriebsdruck:	max. 1 MPa
27268XXX Empfohlener Betriebsdruck:	0,1 - 0,5 MPa
27281XXX / 26596000 Empfohlener Betriebsdruck:	0,13 - 0,5 MPa

Störung	Ursache	Abhilfe
Wenig Wasser	- Versorgungsdruck nicht ausreichend - Schmutzfangsieb der Regeleinheit verschmutzt	- Leitungsdruck prüfen - Schmutzfangsiebe vor dem Thermostat und auf der Regeleinheit reinigen #96922000
Kreuzfluss, warmes Wasser wird bei geschlossener Armatur in die Kaltwasserleitung gedrückt oder umgekehrt	- Siebdichtung der Brause verschmutzt	- Siebdichtung zwischen Brause und Schlauch reinigen
Auslauftemperatur stimmt nicht mit der eingestellten Temperatur überein	- Rückflussverhinderer verschmutzt / defekt	- Rückflussverhinderer reinigen ggf. austauschen
Temperaturregelung nicht möglich	- Thermostat wurde nicht justiert - Zu niedrige Warmwassertemperatur	- Thermostat justieren - Warmwassertemperatur erhöhen auf 42 °C bis 60 °C
Durchlauferhitzer schaltet bei Thermostatbetrieb nicht ein	- Regeleinheit verkalkt - Schmutzfangsiebe verschmutzt - Rückflussverhinderer sitzt fest - Drossel in der Handbrause nicht ausgebaut	- Regeleinheit austauschen - Schmutzfangsiebe reinigen / austauschen - Rückflussverhinderer austauschen - Drossel aus der Handbrause entfernen

Prüfdruck:	1,6 MPa (1 MPa = 10 bar = 147 PSI)
Heißwassertemperatur:	max. 60 °C
Thermische Desinfektion:	70 °C / 4 min
Anschlussmaße:	150±12 mm
Anschlüsse G 1/2:	kalt rechts - warm links

- Eigensicher gegen Rückfließen
- Das Produkt ist ausschließlich für Trinkwasser konzipiert!

Symbolerklärung

 Kein essigsäurehaltiges Silikon verwenden!

 **Justierung** (siehe Seite 34)

Einstellen der Warmwasserbegrenzung. In Verbindung mit Durchlauferhitzern ist eine Warmwassersperre nicht zu empfehlen.

max. ≈ 42 °C Safety Function (siehe Seite 41)

Dank der Safety Function lässt sich die gewünschte Höchsttemperatur von z. B. max. 42 °C voreinstellen.

 **Wartung** (siehe Seite 40)

- Rückflussverhinderer müssen gemäß EN 806-5 regelmäßig in Übereinstimmung mit nationalen oder regionalen Bestimmungen auf ihre Funktion geprüft werden (mindestens einmal jährlich).
- Um die Leichtgängigkeit der Regeleinheit zu gewährleisten, sollte der Thermostat von Zeit zu Zeit auf ganz warm und ganz kalt gestellt werden.

 **Maße** (siehe Seite 36)

 **Durchflussdiagramm** (siehe Seite 36)

- ① Handbrause
- ② Kopfbrause

 **Serviceteile** (siehe Seite 41)

Sonderzubehör (nicht im Lieferumfang enthalten)

 Fliesenausgleichsscheibe #95239000 (siehe Seite 41)

 **Reinigung** (siehe Seite 38)

 **Bedienung** (siehe Seite 35)

Zum Entleeren der Kopfbrause diese nach dem Benutzen leicht schräg stellen.

 **Prüfzeichen** (siehe Seite 41)

Consignes de sécurité

- ⚠ Lors du montage, porter des gants de protection pour éviter toute blessure par écrasement ou coupure.
- ⚠ Le bras de la douchette n'est conçu que pour tenir la douchette et ne doit pas servir à la suspension d'autres objets !
- ⚠ Il est interdit aux enfants ainsi qu'aux adultes ayant des insuffisances physiques, psychiques et/ou motoriques d'utiliser la douche sans surveillance. De même, il est interdit à des personnes sous influence d'alcool ou de drogues d'utiliser la douche.
- ⚠ Éviter le contact du jet de la douchette avec les parties sensibles du corps (telles par ex. que les yeux). Veiller à respecter un écart suffisant entre la douchette et le corps
- ⚠ Le produit ne doit pas servir de poignée. Monter pour cela une poignée séparée.
- ⚠ Le produit ne doit servir qu'à se laver et à assurer l'hygiène corporelle.
- ⚠ Il est conseillé d'équilibrer les pressions de l'eau chaude et froide.

Instructions pour le montage

- Avant son montage, s'assurer que le produit n'a subi aucun dommage pendant le transport. Après le montage, tout dommage de transport ou de surface ne pourra pas être reconnu.
- Les conduites et la robinetterie doivent être montés, rincés et contrôlés selon les normes en vigueur.
- Les directives d'installation en vigueur dans le pays concerné doivent être respectées.
- Les dimensions d'installation indiquées dans la notice de montage sont idéales pour des personnes d'une taille de 1800 mm environ et doivent être ajustées selon le cas. Tenir compte pour cela du fait qu'un changement de hauteur modifie la hauteur minimum et que la modification des cotes de raccord doit entrer en ligne de compte.
- Lors du montage de ce produit par du personnel qualifié, veiller à ce que la surface de fixation soit bien plane dans toute la zone de fixation (pas de dépassement de joints ou de déport de carreaux), à ce que le mur se prête au montage du produit et ne présente aucun point fragile.
- Le joint à filtre fourni avec la pomme de douche à main doit être installé afin de retenir des impuretés du système de conduites. Ceux-ci pourraient influencer le fonctionnement de ce produit et même endommager des pièces mobiles. Des réclamations à la suite de l'usage de la pomme de douche sans joint-tamis de hangrohe ne peuvent pas faire partie de notre garantie.
- Le produit n'est pas prévu pour une utilisation en liaison avec un bain à vapeur
- En cas d'urgence, il est possible de raccourcir, dans la partie inférieure, le tuyau reliant la robinetterie au pommeau de la douche à l'aide d'une scie fine.
- On doit installer dans la tuyauterie eau froide le limiteur de débit (réf. 97510000) fourni, lors de problèmes rencontrés avec un chauffe-eau instantané ou bien lorsqu'il y a une trop grosse différence de pression.

Informations techniques

Pression de service autorisée:	max. 1 MPa
27268XXX Pression de service conseillée:	0,1 - 0,5 MPa
27281XXX / 26596000 Pression de service conseillée:	0,13 - 0,5 MPa
Pression maximum de contrôle:	1,6 MPa

Dysfonctionnement	Origine	Solution
Pas assez d'eau	- Pression d'alimentation insuffisante	- Contrôler la pression
	- Filtre de l'élément thermostatique encrassé	- Nettoyer les filtres devant le mitigeur thermostatique et sur la cartouche #96922000
	- Joint-filtre de douchette encrassé	- Nettoyer le joint-filtre entre la douchette et le flexible
Circulation opposée, l'eau chaude est comprimée dans l'arrivée d'eau froide et vice versa avec robinet fermé	- Clapet anti-retour encrassé ou défectueux	- Nettoyer le clapet anti-retour ou le changer éventuellement
	- Le thermostat n'a pas été réglé	- Régler le thermostat
La température à la sortie ne correspond pas à la température de réglage	- Température d'eau chaude trop basse, pas d'eau froide	- Augmenter la température d'eau chaude entre 42°C et 60°C
	- Cartouche thermostatique entartrée	- Changer la cartouche thermostatique
Le chauffe-eau instantané ne s'allume pas lors de l'utilisation du thermostat	- Filtres encrassés	- Nettoyez / changez les filtres
	- Clapet anti-retour bloqué	- Changez le clapet anti-retour
	- Réducteur de débit non démonté	- Démontez le réducteur de débit de la douchette

(1 MPa = 10 bar = 147 PSI)

Température d'eau chaude: max. 60°C
 Désinfection thermique: 70°C / 4 min
 Dimension d'arrivée: 150±12 mm
 Raccordement G 1/2: froide à droite - chaude à gauche

- Avec dispositif anti-retour
- Le produit est exclusivement conçu pour de l'eau potable!

Description du symbole

Ne pas utiliser de silicone contenant de l'acide acétique!

Etalonnage (voir pages 34)

Réglage de la limitation d'eau chaude. En liaison avec les chauffe-eau, un blocage de l'eau chaude n'est pas recommandable.

max. ≈ 42°C Safety Function (voir pages 41)

Grâce à la fonction Safety, il est possible de prérégler la température maximale par exemple max. 42°C souhaitée.

Entretien (voir pages 40)

- Les clapets anti-retour doivent être examinés régulièrement conformément à la norme EN 806-5 ou conformément aux dispositions nationales ou régionales quant à leur fonction (au moins une fois par an).
- Pour assurer le mouvement facile de l'élément thermostatique, le thermostat devrait être placé de temps en temps en position très chaude et très froide.

Dimensions (voir pages 36)

Diagramme du débit (voir pages 36)

- ① Douchette
- ② Pomme de douche

Pièces détachées (voir pages 41)

Accessoires en option (ne fait pas partie de la fourniture)

cale de compensation #95239000 (voir pages 41)

Nettoyage (voir pages 38)

Instructions de service (voir pages 35)

Pour vider le pommeau de la douchette, l'incliner légèrement après l'utilisation.

Classification acoustique et débit (voir pages 41)



Safety Notes

- ⚠ Gloves should be worn during installation to prevent crushing and cutting injuries.
- ⚠ The arm of the shower head is intended only to hold the shower head. Do not load it down with other objects!
- ⚠ Children as well as adults with physical, mental and/or sensoric impairments must not use this product without proper supervision. Persons under the influence of alcohol or drugs are prohibited from using this product.
- ⚠ Do not allow the streams of the shower touch sensitive body parts (such as your eyes). An adequate distance must be kept between the shower and you.
- ⚠ The product may not be used as a holding handle. A separate handle must be installed.
- ⚠ The product may only be used for bathing, hygienic and body cleaning purposes.
- ⚠ The hot and cold supplies must be of equal pressures.

Installation Instructions

- Prior to installation, inspect the product for transport damages. After it has been installed, no transport or surface damage will be honoured.
- The pipes and the fixture must be installed, flushed and tested as per the applicable standards.
- The plumbing codes applicable in the respective countries must be observed.
- The installation dimensions stated in these installation instructions are ideal for people of approximately 1800 mm in body height. The dimensions can be altered if required. In this case, pay attention to the fact that a change of installation height will also change the minimum height, and that the altered mounting dimensions must be taken into consideration.
- During installation of the product by qualified trained personnel, make sure that the entire fastening surface is even and smooth (no protruding seams or tile offset), that the finish of the wall is suitable to apply the product and has no weak points.
- The mesh washer must be insert to protect the shower against incoming dirt by pipework. Incoming dirt leads to defects or/and can damage parts of the shower; such caused faults voids all liability and guarantee claims.
- The product is not designed to be used with steam baths!
- If required, the bottom part of the pipe between the fixture and the shower head can be shortened with a fine-toothed saw.
- In case of problems with the continuous water heater or of greatly varying water pressures, you must install the water limiter (comprised in the delivery, article number 97510000) in the cold water supply.

Technical Data

Operating pressure:	max. 1 MPa
27268XXX Recommended operating pressure:	0,1 - 0,5 MPa
27281XXX / 26596000 Recommended operating pressure:	0,13 - 0,5 MPa
Test pressure:	1,6 MPa
	(1 MPa = 10 bar = 147 PSI)
Hot water temperature:	max. 60 °C
Thermal disinfection:	70 °C / 4 min
Centre distance:	150±12 mm
Connections G 1/2:	cold right - hot left

Fault	Cause	Remedy
Insufficient water	- Supply pressure inadequate	- Check water pressure (If a pump has been installed check to see if the pump is working).
	- Regulator filter dirty	- Clean filter in front of the mixer and on the MTC-thermo cartridge #96922000
	- Shower filter seal dirty	- Clean filter seal between shower and hose
Crossflow, hot water being forced into cold water pipe, or vice versa, when mixer is closed	- Backflow preventers dirty or leaking	- Clean backflow preventers, exchange if necessary
Spout temperature does not correspond with temperature set	- Thermostat has not been adjusted	- Adjust thermostat
	- Hot water temperature too low	- Increase hot water temperature to 42 °C to 60 °C
Temperature regulation not possible	- thermo cartridge calcified	- Exchange thermo cartridge
Instantaneous heater didn't work with thermostat	- Filters are dirty	- Clean the filter / exchange filter
	- check valve hasn't moved back	- Exchange check valves
	- Flow limiter in handshower isn't removed	- Remove flow limiter

- Safety against backflow
- The product is exclusively designed for drinking water!

Symbol description



Do not use silicone containing acetic acid!



Adjustment (see page 34)

To adjust the hot water limiter. Using a hot water limiter in combination with a continuous flow water heater is not recommended.

max. $\approx 42^{\circ}\text{C}$ Safety Function (see page 41)

The desired maximum temperature for example max. 42° C can be pre-set thanks to the safety function.



Maintenance (see page 40)

- The check valves must be checked regularly according to EN 806-5 in accordance with national or regional regulations (at least once a year).
- To guarantee the smooth running of the thermostat, it is necessary from time to time to turn the thermostat from total hot to total cold.



Dimensions (see page 36)



Flow diagram (see page 36)

- ① Hand shower
- ② Overhead shower



Spare parts (see page 41)

Special accessories (order as an extra)



tile-matching-disk #95239000 (see page 41)



Cleaning (see page 38)



Operation (see page 35)

To empty the overhead shower after use, hold it in a slightly inclined position.



Test certificate (see page 41)



Indicazioni sulla sicurezza

- ⚠ Durante il montaggio, per evitare ferite da schiacciamento e da taglio bisogna indossare guanti protettivi.
- ⚠ Il braccio del soffione della doccia è progettato per sostenere solo quest'ultimo, non va sovraccaricato con altri oggetti!
- ⚠ I bambini e gli adulti affetti da menomazioni fisiche, psichiche e/o sensoriali devono utilizzare il sistema doccia solo sotto sorveglianza. Il prodotto non deve essere utilizzato da persone sotto l'effetto di droghe o alcolici.
- ⚠ Bisogna evitare il contatto fra il getto della doccia e parti del corpo delicate (ad es. gli occhi). Fra il soffione ed il corpo va mantenuta una distanza sufficiente.
- ⚠ Il prodotto non deve essere utilizzato come maniglia, questa deve essere montata separatamente.
- ⚠ Il prodotto deve essere utilizzato esclusivamente per fare il bagno e per l'igiene del corpo.
- ⚠ Attenzione! Compensare le differenze di pressione tra i collegamenti dell'acqua fredda e dell'acqua calda.

Istruzioni per il montaggio

- Prima del montaggio è necessario controllare che non ci siano stati danni durante il trasporto. Una volta eseguito il montaggio, non verranno riconosciuti eventuali danni di trasporto o delle superfici.
- Montare, lavare e controllare tubature e rubinetteria rispettando le norme correnti.
- Vanno rispettate le direttive di installazione nazionali vigenti nel rispettivo paese.
- Le quote di montaggio indicate nelle istruzioni di montaggio sono ideali per persone grandi circa 1800 mm e eventualmente vanno adattate. A ciò bisogna fare attenzione, che ad altezza di montaggio cambiata l'altezza minima necessaria indicata cambia e che bisogna considerare la modifica delle quote di collegamento.
- Per il montaggio del prodotto da personale specializzato qualificato bisogna fare attenzione, che la superficie di fissaggio, in tutto il campo di fissaggio, sia piana (nessuna giunzione sporgente o sfalsamento di piastrella), la costruzione della parete sia adatta al montaggio del prodotto e che non presenti alcun punto debole.
- Per proteggere la soffione doccia da eventuali impurità provenienti dalle tubazioni dell'acqua, deve essere inserito il filtro nell'impugnatura della doccia stessa. Tali impurità possono infatti causare difetti e/o danneggiare parti della doccia; in questo caso la Hansgrohe non risponde dei danni.
- Il prodotto non è predisposto per l'impiego in combinazione con un bagno a vapore.
- Se necessario il tubo può essere accorciato tra il raccordo e la doccetta nella parte inferiore usando un seghetto.
- In caso di problemi con lo scaldacqua istantaneo oppure di grandi differenze di pressione bisogna inserire il limitatore di portata in dotazione (codice articolo 97510000) nel tubo d'entrata dell'acqua fredda.

Dati tecnici

Pressione d'uso: max. 1 MPa
 27268XXX Pressione d'uso consigliata: 0,1 - 0,5 MPa

27281XXX / 26596000 Pressione d'uso consigliata: 0,13 - 0,5 MPa
 Pressione di prova: 1,6 MPa
 (1 MPa = 10 bar = 147 PSI)

Temperatura dell'acqua calda: max. 60°C
 Disinfezione termica: 70°C / 4 min
 Distanza di raccordo: 150±12 mm
 Raccordi G 1/2: fredda a destra - calda a sinistra

- Sicurezza antiriflusso
- Il prodotto è concepito esclusivamente per acqua potabile!

Descrizione simbolo

 Non utilizzare silicone contenente acido acetico!

 **Taratura** (vedi pagg. 34)

Regolazione del limitatore di erogazione d'acqua calda. Un limitatore di erogazione di acqua calda in combinazione con le caldaie istantanee non è consigliabile.

max. ≈ 42°C Safety Function (vedi pagg. 41)

Grazie alla funzione antiscottature Safety la temperatura massima per esempio max. 42°C desiderata è facilmente regolabile.

 **Manutenzione** (vedi pagg. 40)

- La valvola di non ritorno deve essere controllata regolarmente come da EN 806-5, secondo le normative nazionali e regionali (almeno una volta all'anno).
- Per garantire la scorrevolezza dell'elemento di regolazione, di tanto in tanto si dovrebbe regolare il termostatico passando da tutto caldo a tutto freddo.

 **Ingombri** (vedi pagg. 36)

 **Diagramma flusso** (vedi pagg. 36)

- ① Doccetta
- ② Soffione doccia

 **Parti di ricambio** (vedi pagg. 41)

Accessori speciali (non contenuto nel volume di fornitura)

 distanziali da piastrella #95239000 (vedi pagg. 41)

 **Pulitura** (vedi pagg. 38)

 **Procedura** (vedi pagg. 35)

Per svuotare la doccia di testa dopo averla usata, posizionarla leggermente obliqua.

 **Segno di verifica** (vedi pagg. 41)

Problema	Possibile causa	Rimedio
Scarsità d'acqua	- Pressione di erogazione insufficiente - Filtro dell'unità di regolazione sporco - Guarnizione del filtro della doccia sporca	- Provare la pressione di erogazione - Pulire/sostituire i filtri #96922000 - Pulire la guarnizione del filtro tra doccia e flessibile
Flusso incrociato; l'acqua calda viene spinta nella tubatura acqua fredda a rubinetteria chiusa o viceversa	- Antiriflusso sporco o non ermetico	- Pulire o sostituire l'antiriflusso
La temperatura di erogazione diversa da quella impostata	- Il termostatico non è stato regolato - Temperatura dell'acqua calda	- Regolare il termostatico - Aumentare la temperatura acqua calda tra 42 °C e 60 °C
Impossibile la regolazione temperatura	- Unità di regolazione piena di calcare	- Sostituire l'unità di regolazione
La caldaia istantanea non lavora con il termostato in funzione	- Filtri sporchi - Valvola antiriflusso non funziona correttamente - Il limitatore di portata non è stato smontato dalla doccetta	- Pulire / sostituire i filtri - Sostituire la valvola antiriflusso - Smontare il limitatore di portata dalla doccetta

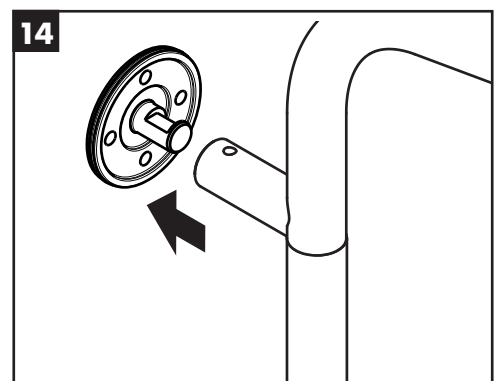
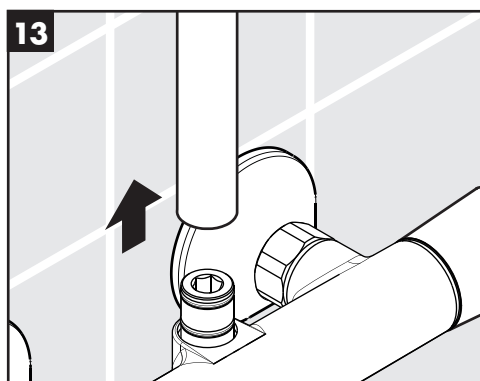
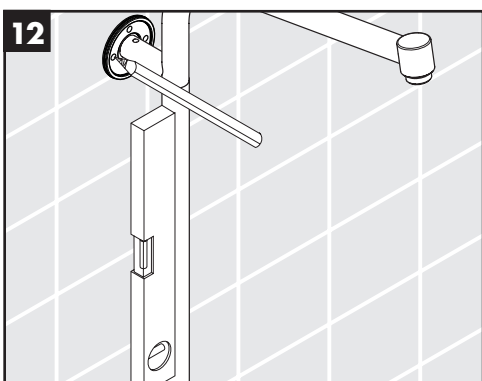
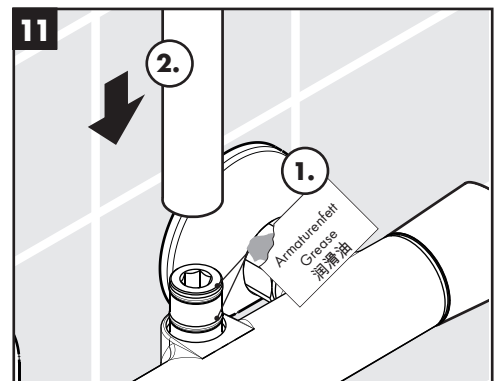
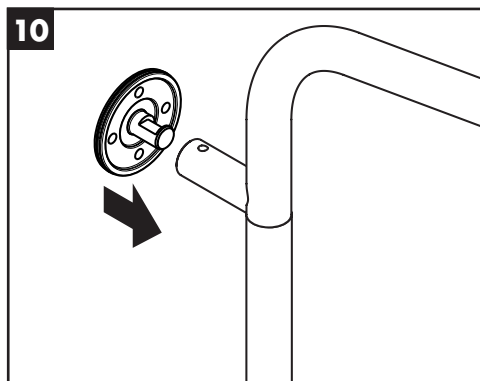
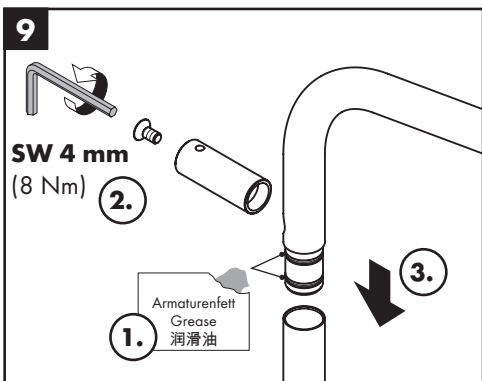
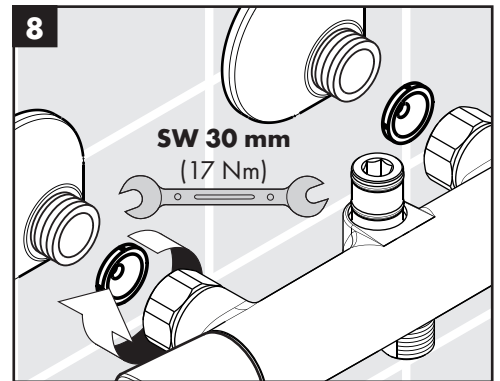
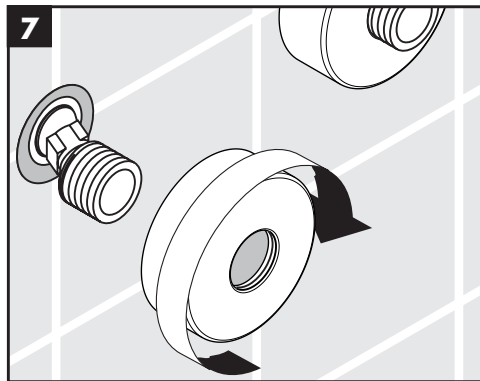
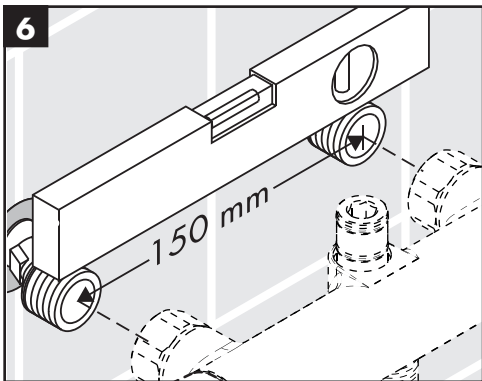
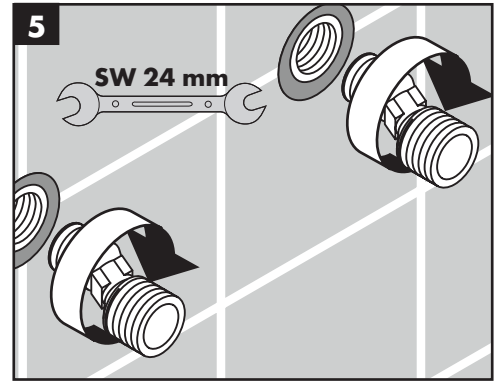
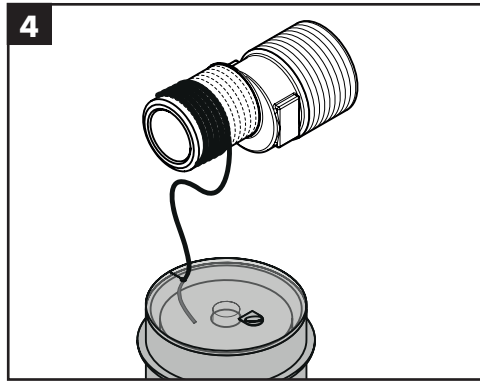
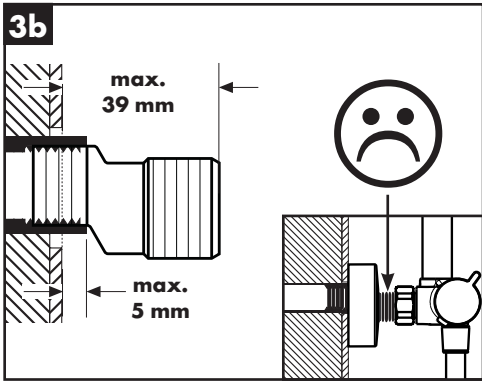
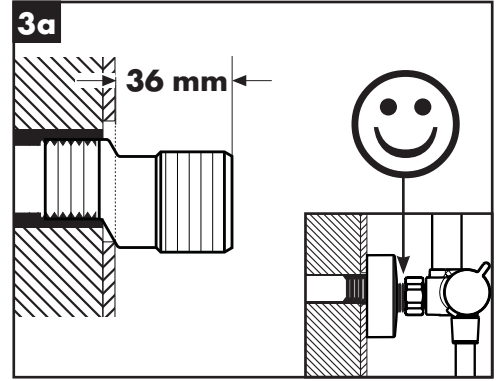
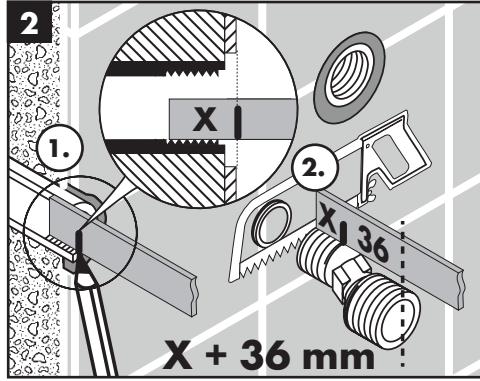
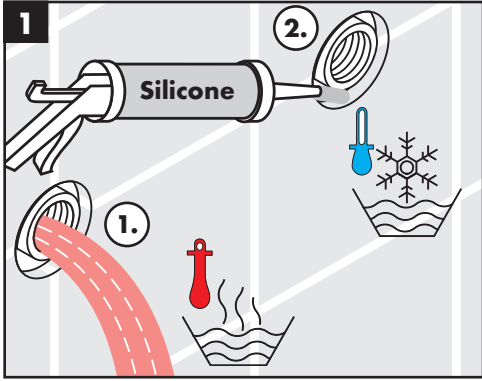

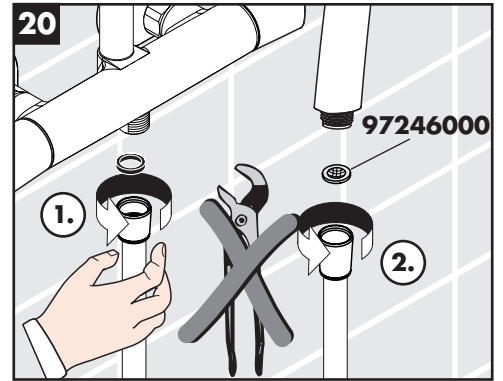
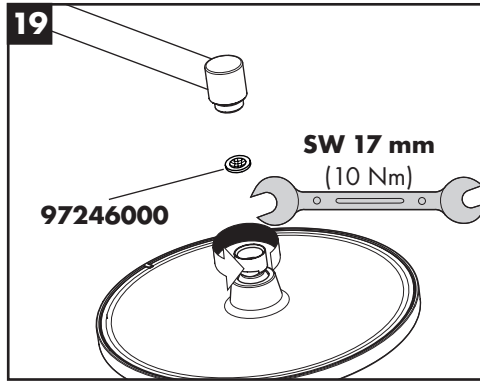
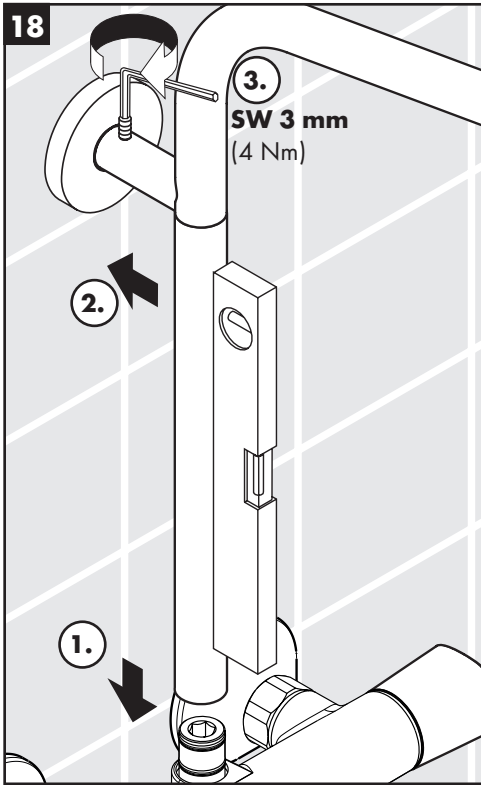
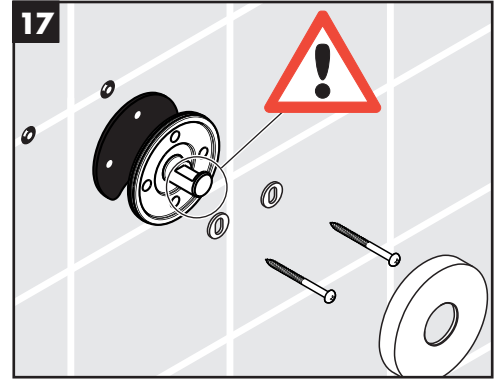
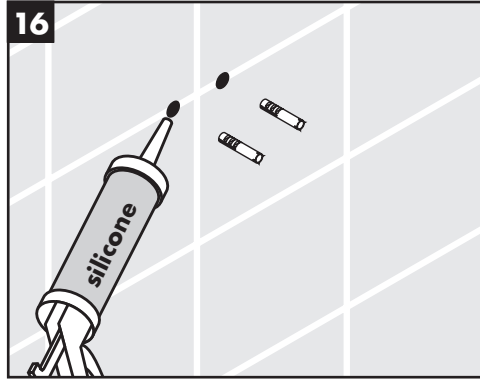
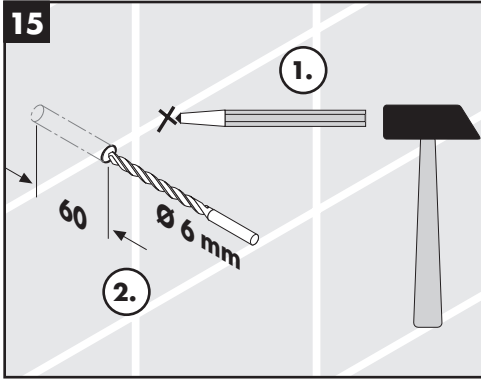

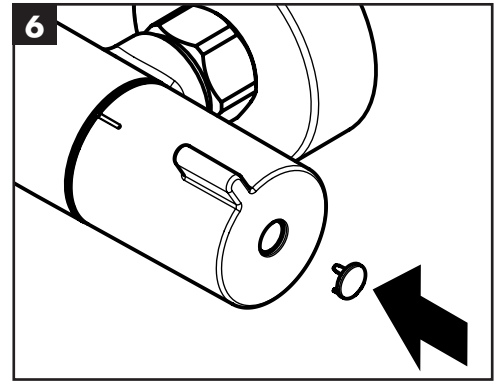
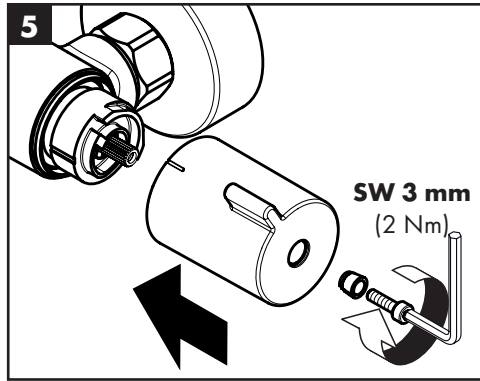
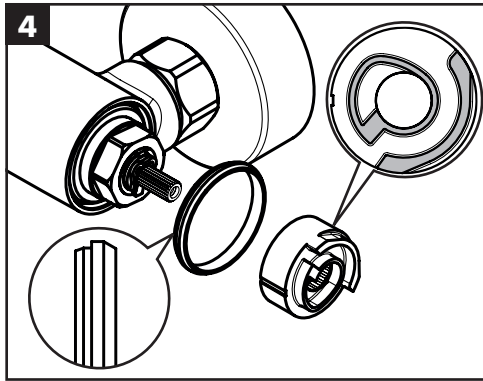
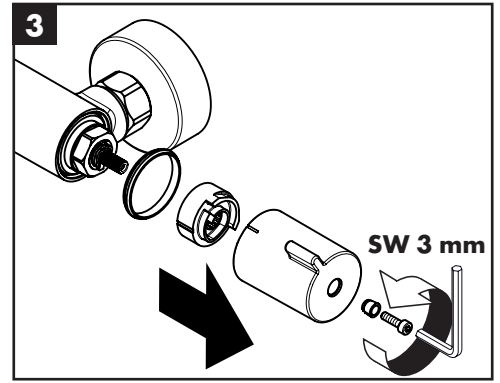
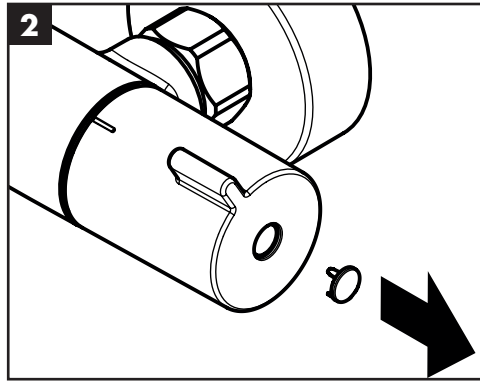
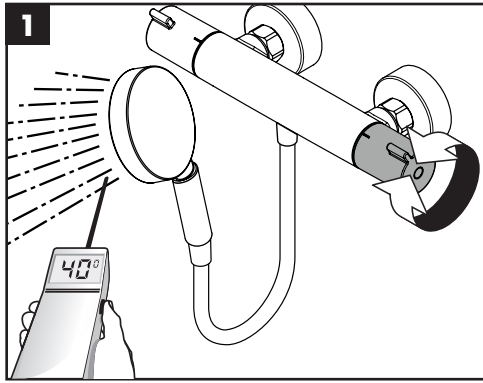

max.
≈ 42 °C

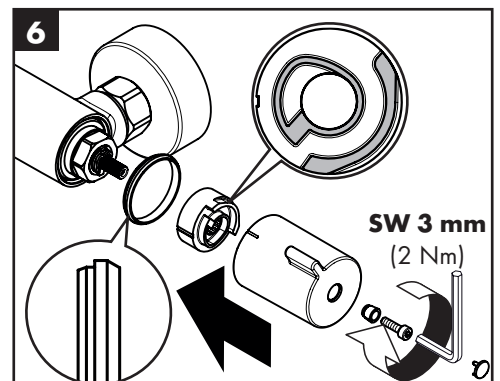
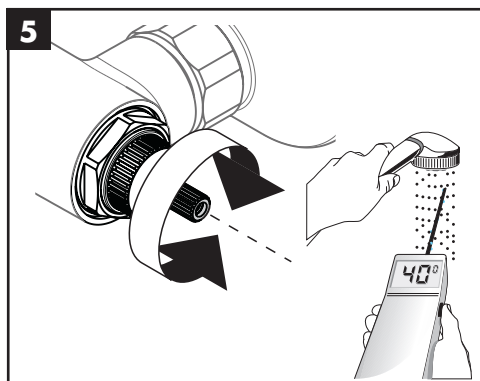
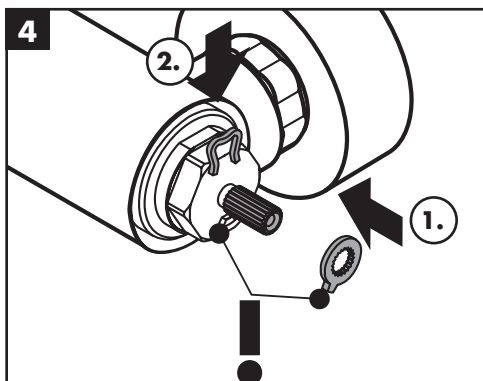
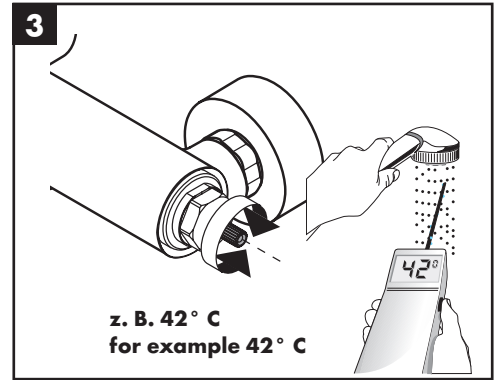
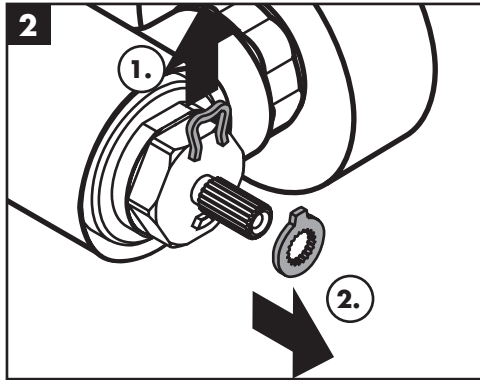
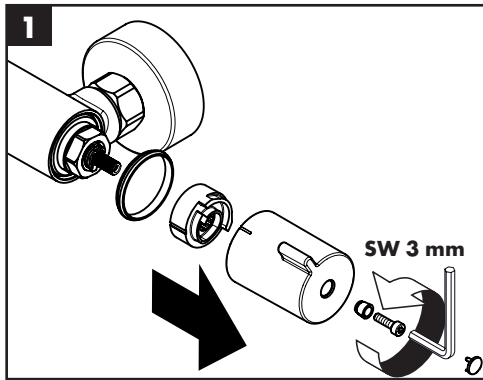

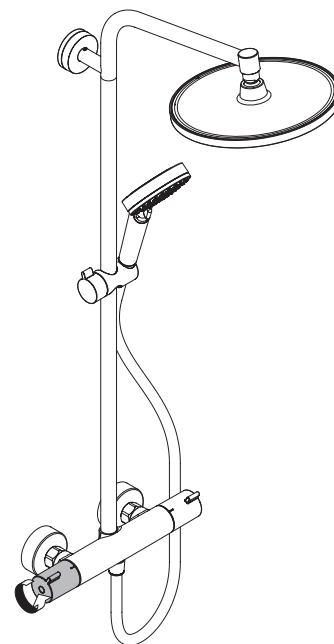
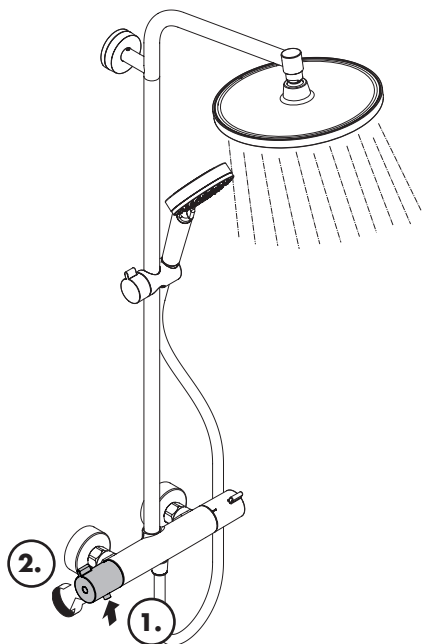
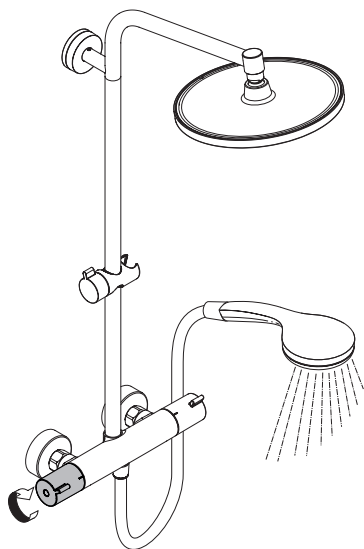

öfñen / ouvert / open / aperto / abierto / open / åbne / abrir / otworzyć / otevřít / otvorit / 开 / открыть / nyítás / avaaminen / öpna / atidaryti / Отваряње / açmak / deschide / ανοικτό / odpreti / avage / atvērt / otvoriti / åpne / отварање / hare / فتح / 開く

schließen / fermé / close / chiudere / cerrar / sluiten / lukke / fechar / zamknąć / zavřít / uzavrieť / 关 / закрыть / bezárás / sulkeminen / stänga / uždaryti / Zatvaranje / kapatmak / închide / κλειστό / zapreti / sulgege / aizvērt / zatvori / lukke / затварање / mbylle / إغلاق / 閉じる

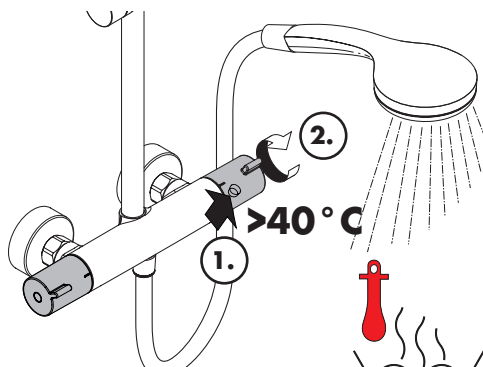
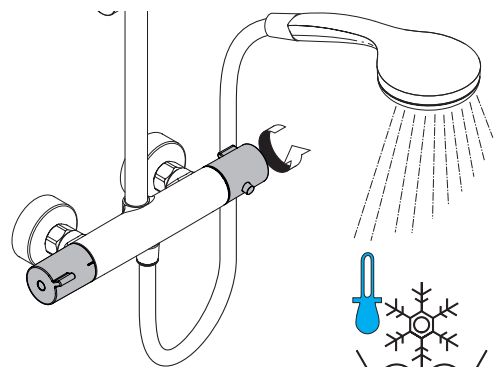

kalt / froid / cold / freddo / frío / koud / koldt / fría / zimna / studená / studená / 冷 / холодная / hideg / kylmä / kallt / šaltas / Hladno / soğuk / rece / κρύο / mrzlo / külm / auksts / hladno / kaldt / студено / i ftohtë / بارد / 冷たい

warm / chaud / hot / caldo / caliente / warm / varmt / quente / ciepła / teplá / teplá / 热 / горячая / meleg / lämmin / varmt / karštas / Vruća voda / sıcak / cald / ζεστό / toplo / kuum / karsts / topla / varm / топло / i ngröhtë / ساخن / 温かい

Crometta Vario EcoSmart 9 l/min
26332XXX

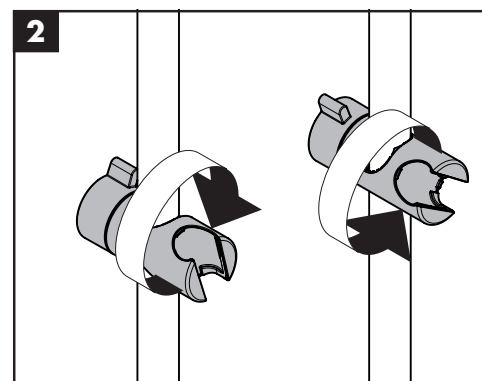
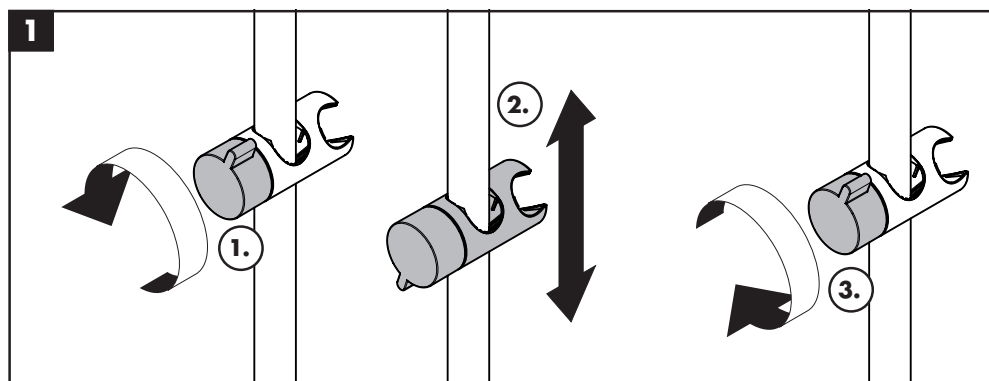
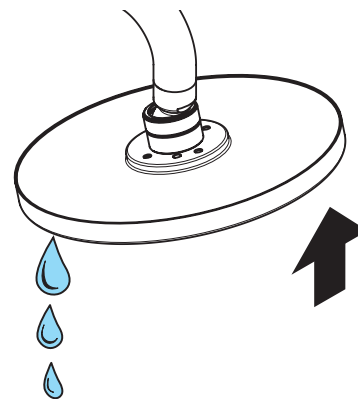
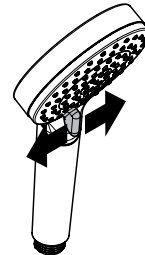

Crometta S 240 1jet Showerpipe EcoSmart
27268XXX

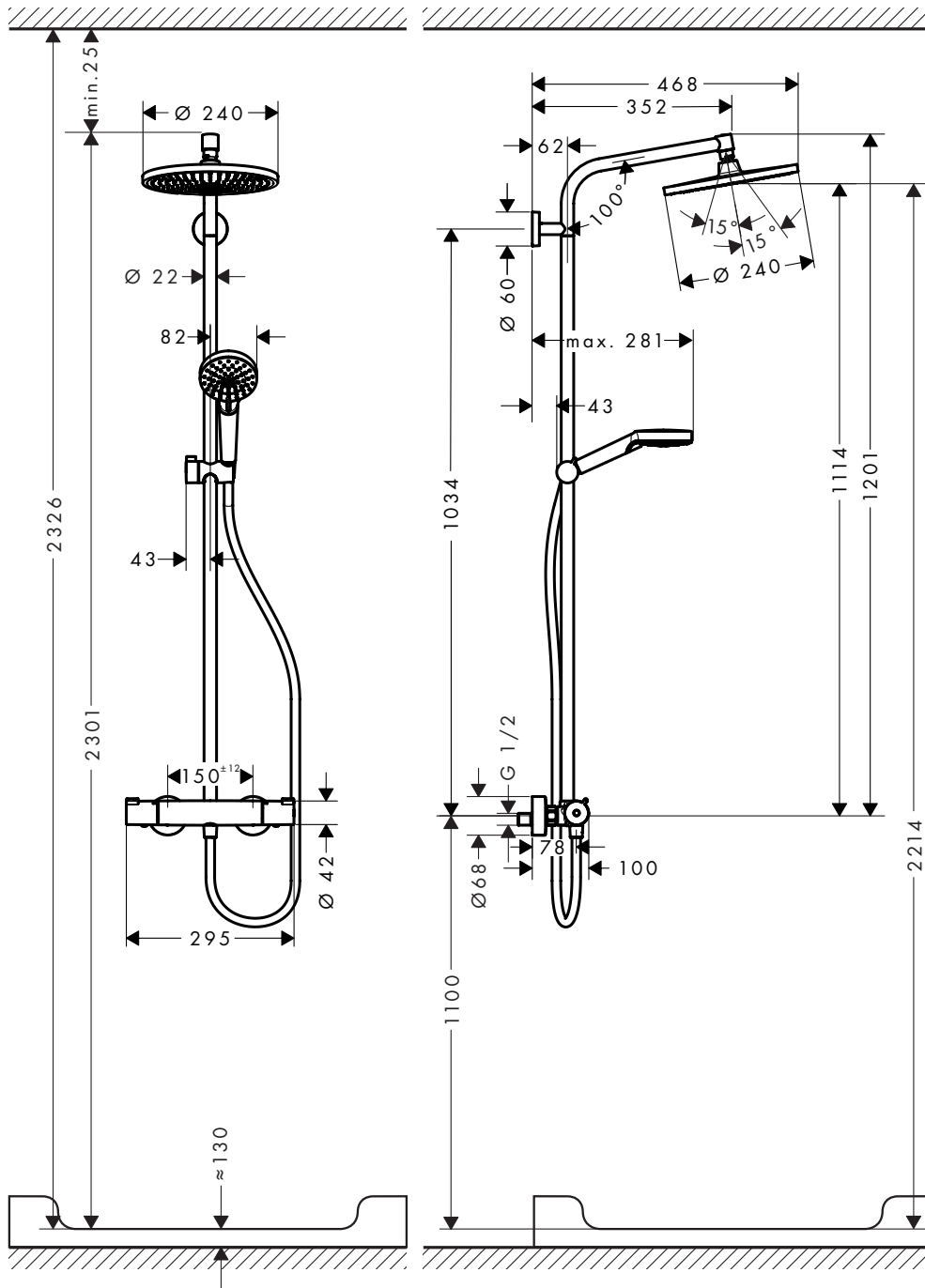

Crometta S 240 1jet Showerpipe EcoSmart
27268XXX

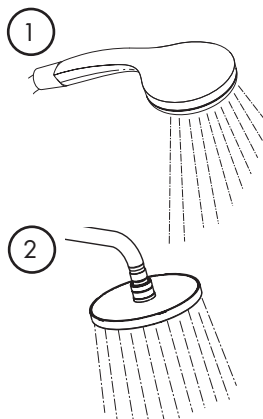
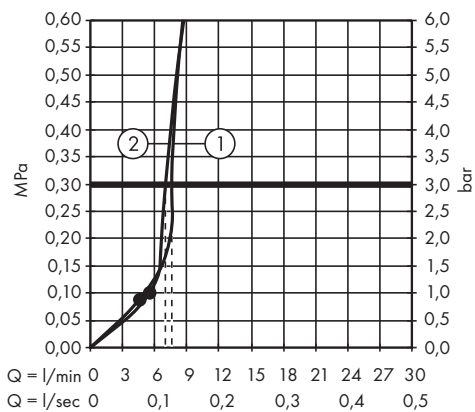

Crometta E 240 1jet Showerpipe EcoSmart
27281XXX / 26596000

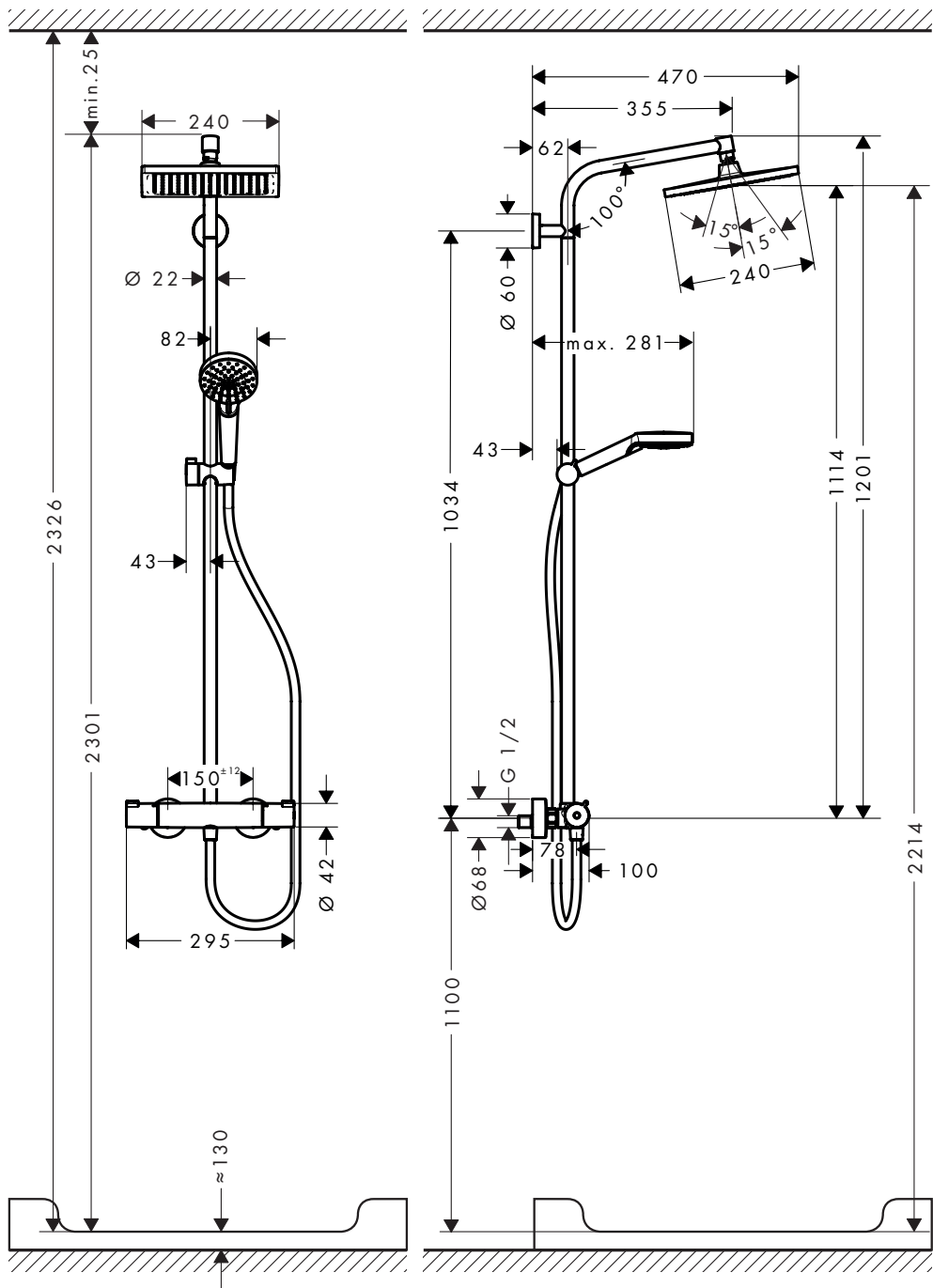

Crometta E 240 1jet Showerpipe EcoSmart
27281XXX / 26596000

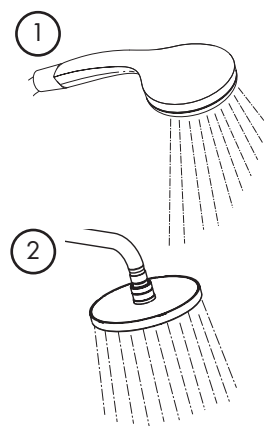
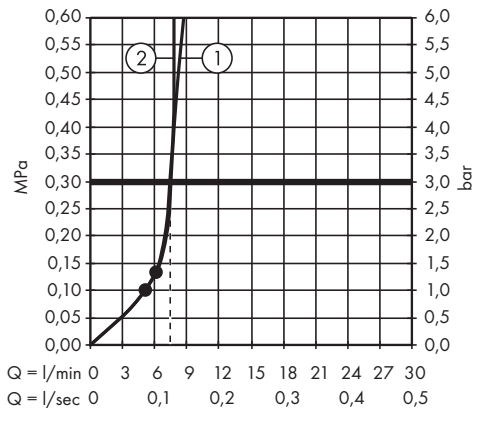



[www.hansgrohe.com/
cleaning-recommendation](http://www.hansgrohe.com/cleaning-recommendation)

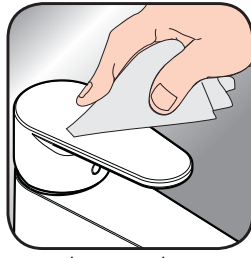

[www.hansgrohe.com/
cleaning-recommendation](http://www.hansgrohe.com/cleaning-recommendation)



[www.hansgrohe.com/
cleaning-recommendation](http://www.hansgrohe.com/cleaning-recommendation)



[www.hansgrohe.com/
cleaning-recommendation](http://www.hansgrohe.com/cleaning-recommendation)

- DE** Reinigungsempfehlung / Garantie / Kontakt
FR Recommendation pour le nettoyage / Garanties / Contact
EN Cleaning recommendation / Warranty / Contact
IT Raccomandazione di pulizia / Garanzia / Contatto
ES Recomendaciones para la limpieza / Garantía / Contacto
NL Aanbevelingen inzake reiniging / Garantie / Contact
DK Rengøringsvejledning / Garanti / Kontakt
PT Recomendações de limpeza / Garantia / Contacto
PL Zalecenie dotyczące pielęgnacji / Gwarancja / Kontakt
CS Doporučení k čištění / Záruka / Kontakt
SK Odporúčania pre čistenie / Záruka / Kontakt
ZH 清洁指南 / 担保 / 接触
RU Рекомендации по очистке / Гарантия / Контакты
FI Puhdistussuositus / Takuu / Kosketus
SV Rengöringsrekommendationer / Garanti / Contacto
LT Valymo rekomendacijos / Garantija / Kontaktai

- HR** Preporuke za čišćenje / Garancija / Kontakt
TR Temizleme önerisi / Garanti / Temas
RO Recomandări pentru curățare / Garanție / Contact
EL Σύσταση καθαρισμού / Εγγύηση / επαφή
SL Priporočilo za čiščenje / Garancija / Kontakt
ET Puhastussoovitused / Garantii / Kontakt
LV Tīrīšanas ieteikumi / Garantija / Kontakti
SR Preporuke za čišćenje / Garancija / Kontakt
NO Anbefaling for rengjøring / Garanti / Kontakt
BG Препоръка за почистване / Гаранция / Контакт
SQ Këshilla rreth pastrimit / Garancia / Kontakt
KO 세정시 권장사항 / 품질보증 / 접촉
AR توصيات التنظيف / الضمان (الولايات المتحدة الأمريكية) / اتصال
HU Tisztítási tanácsok / Garancia / érintkezés
JP お手入れの方法 / 保証について / ご連絡先

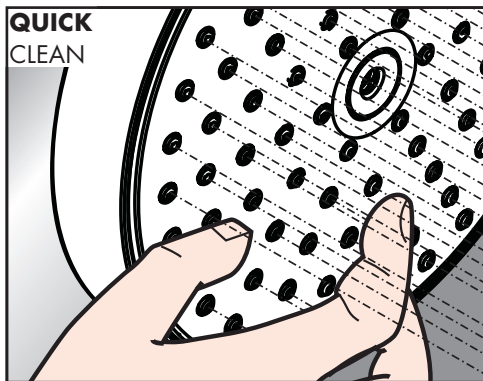

- DE** Einfach sauber: Kalk lässt sich von den Noppen ganz leicht abrubbeln.
FR La propreté en toute simplicité: les dépôts formés sur les buses élastiques en silicone s'éliminent par un simple passage de la main.
EN Just clean: simply rub over the spray nozzles to remove lime scale.
IT Facile da pulire: Il calcare viene eliminato semplicemente dagli ugelli elastici in silicone.
ES Fácil asear: La cal se puede retirar sencillamente frotando con los dedos de las toberas elásticas de silicona.
NL Eenvoudig schoon: Kalk kan eenvoudig van de noppen worden gewreven.
DK Enkel rengøring: Det er let at fjerne kalkaflejringer fra stråledyserne.
PT Simplesmente limpo: o calcário pode ser simplesmente retirado das saídas através de fricção.
PL Po prostu czysto: Pęczki można całkiem łatwo oczyścić z kamienia.

- CS** Jednoduše čistě: Vapenné usazeniny můžete z noplek snadno odstranit otřením.
SK Jednoducho čistý: Vodný kameň sa dá zo štetín celkom ľahko odstrániť.
ZH 清洁: 只需要揉搓花洒表面的出水孔即可去除水垢。
RU Простота чистки: известь очень легко стирается с утолщений.
FI Yksinkertaisesti puhdas: kalkin voi helposti hieroa irti nypyistä.
SV Enkelt att göra rent: det är lätt att ta bort kalk från nopporna.
LT Paprasta švara: kalkės lengvai nugrandomos nuo kilpos.
HR Jednostavno čisto: Kamenac se sasvim lako uklanja s izbočina.
TR Sadece temiz: Kireç, düğümlele kolayca ovalanabilir.
RO Pur și simplu curat: Calcarul se îndepărtează ușor de pe noduri prin frecare.
EL Απλά τέλεια καθαριότητα: Τα άλata μπορούν να αφαιρεθούν με μεγάλη ευκολία από τα σπόμενα.
SL Preprosto čisto: apnenec se z lahkoto podrgne z vozličkov.
ET Lihtsalt puhas: lujja saab nuppudelt lihtsalt maha hõõruda.
LV Vienkārša tīrīšana: kaļķis no izvirzījumiem ir viegli norubināms.
SR Jednostavno čisto: Kamenac se sasvim lako skida sa izbočina.
NO Simpelten ren: Ved å gnikke er det lett å fjerne kalk fra nuppene.
BG Просто чисто: Варовикът лесно може да се изтърси от удебеленията.
SQ Thjesht dhe pastër. Mbetjet gëlqerore mund të hiqen me fërkim të lehtë.
AR إنه سهل التنظيف، حيث يسقط الجير بسهولة شديدة من الأجزاء الناعمة
HU Egyszerűen tiszta: a vízkő egészen könnyen ledörzsölhető a csomókról.
JP 清掃が簡単: カルキは突起部から簡単にこすり落とすことができます。

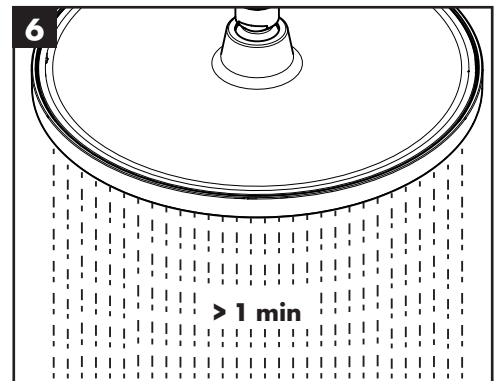
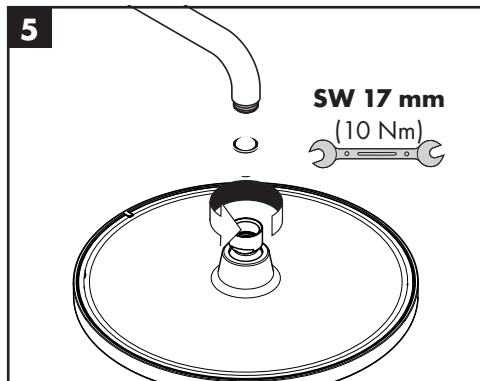
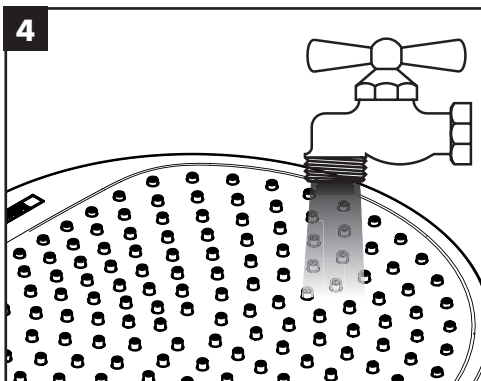
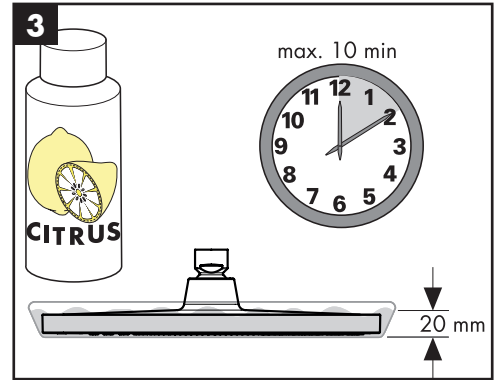
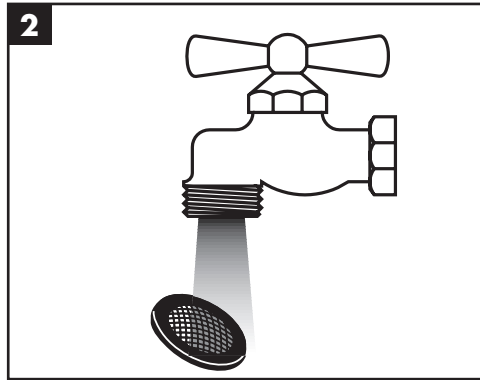
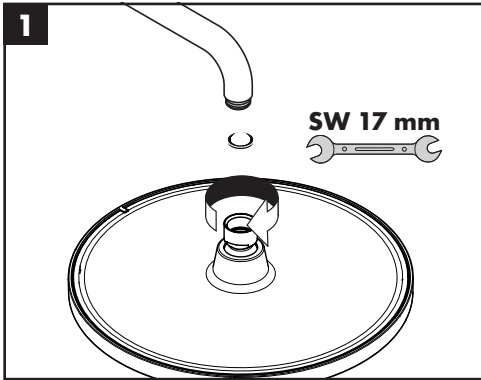
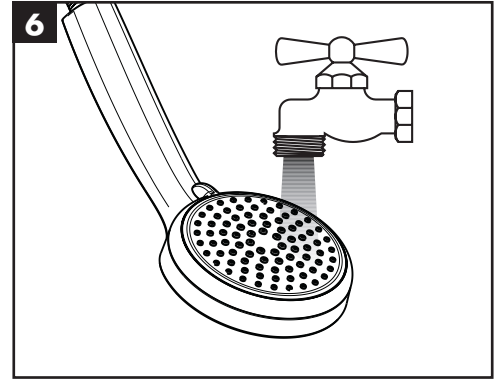
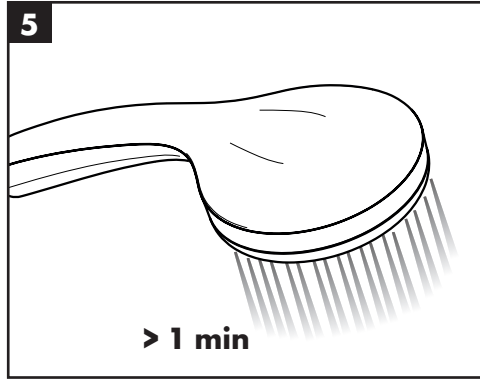
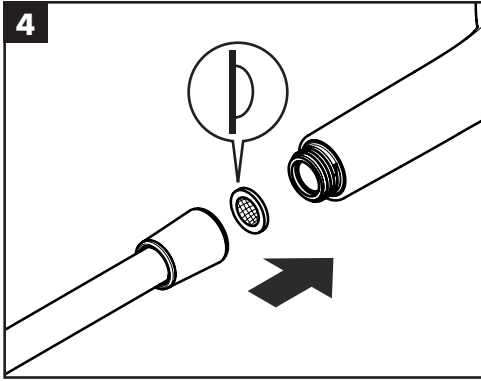
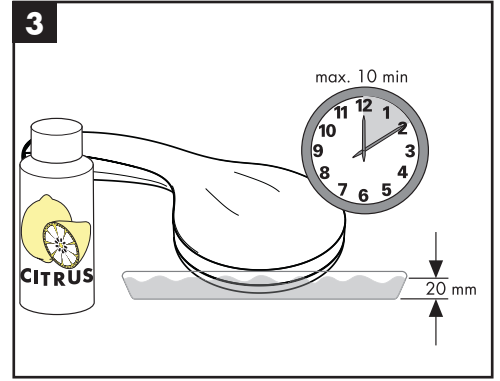
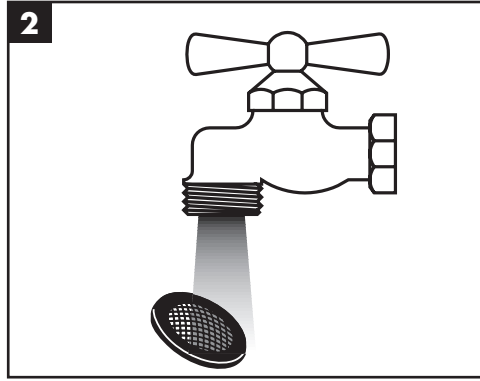
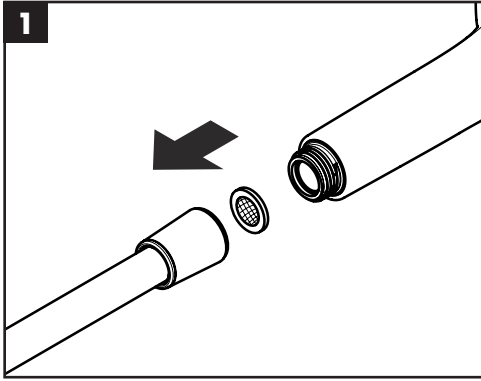

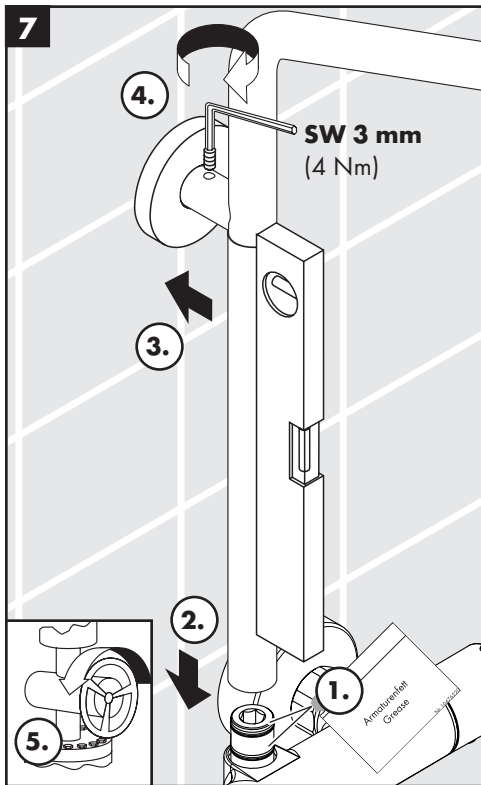
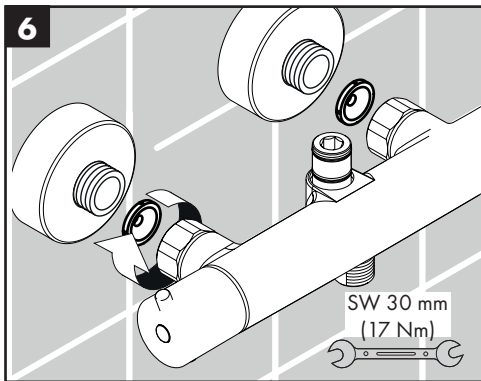
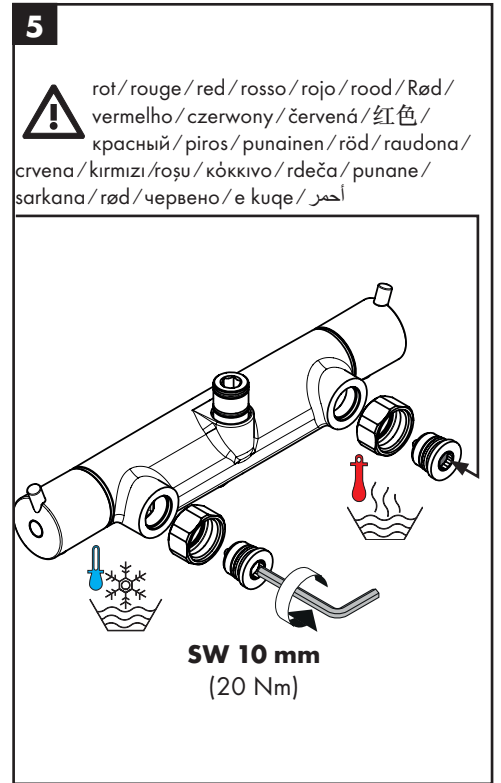
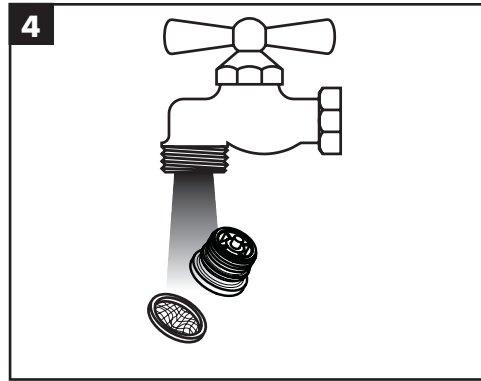
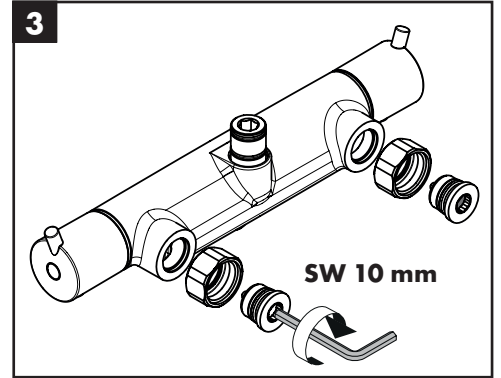
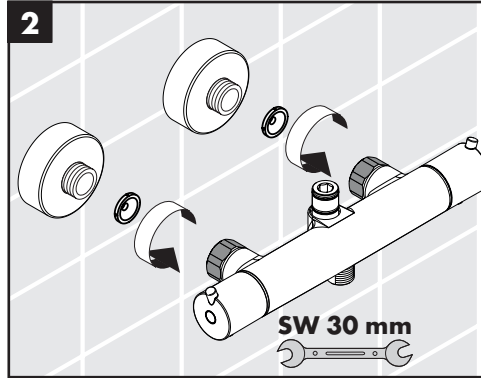
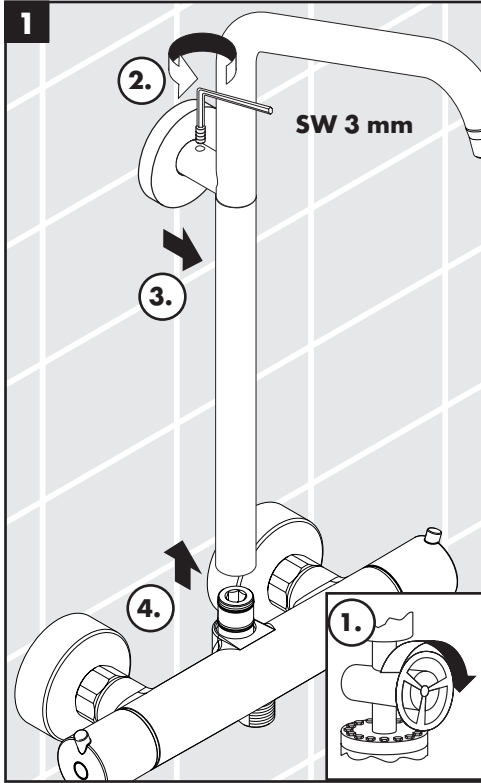

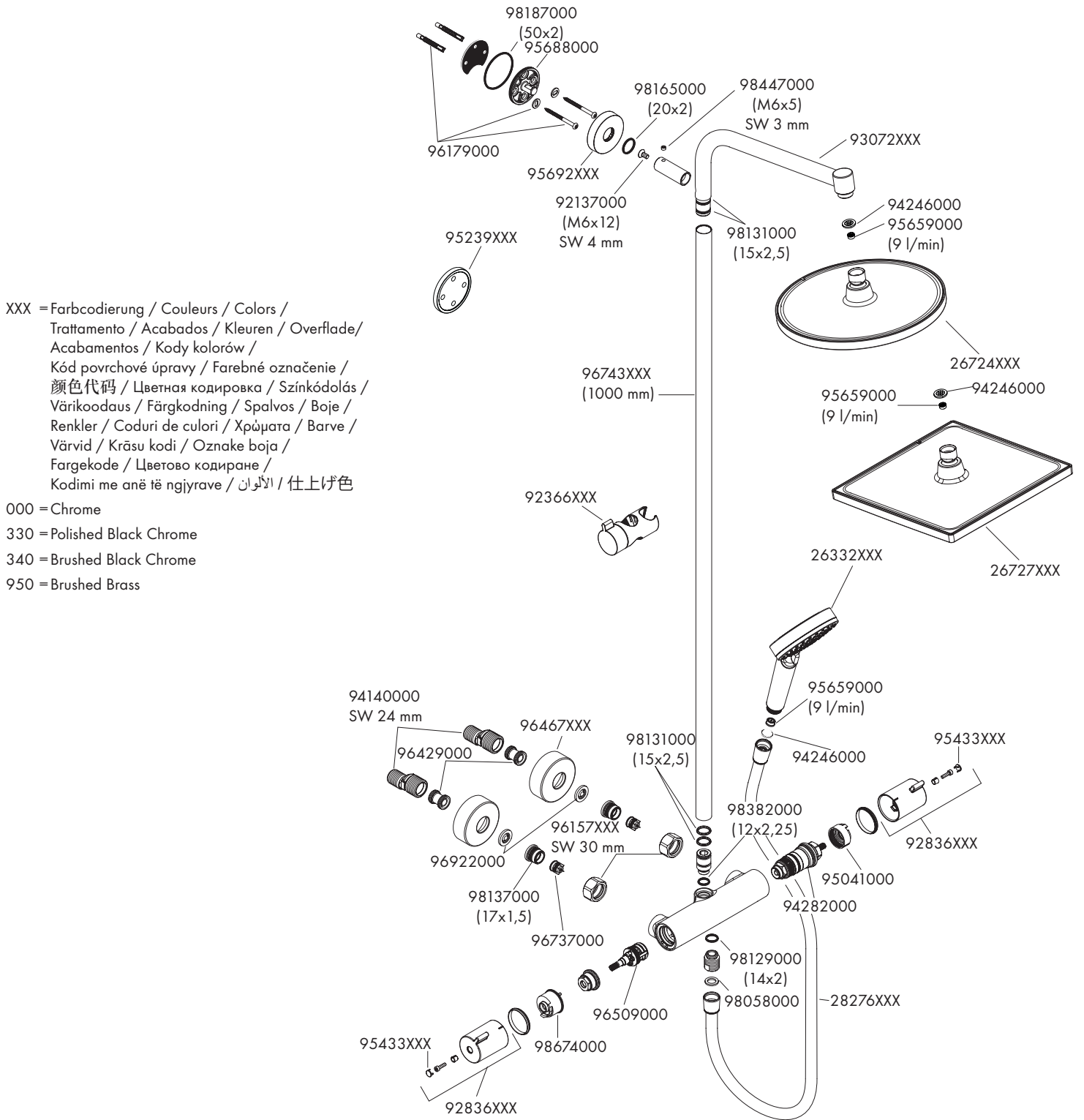

XXX = Farbcodierung / Couleurs / Colors /
Trattamento / Acabados / Kleuren / Overflade/
Acabamentos / Kody kolorów /
Kód povrchové úpravy / Farebné označenie /
颜色代码 / Цветная кодировка / Színkódolás /
Värikoodaus / Färgkodning / Spalvos / Boje /
Renkler / Coduri de culori / Χρώματα / Barve /
Värvvid / Krāsu kodi / Označke boja /
Fargekode / Цветово кодиране /
Kodimi me anë të ngjyrave / الألوان / 仕上げ色

000 = Chrome
330 = Polished Black Chrome
340 = Brushed Black Chrome
950 = Brushed Brass



P-IX	DVGW	SINTEF	NF	STF	CERTIFICATION BODY KIWA	ETA	GODKENDT TIL DRILKEVAND
27268XXX			X		X		
27281XXX			X		X		
26596000					X		

hansgrohe

Hansgrohe · Auestraße 5 – 9 · D-77761 Schiltach · Telefon +49 (0) 78 36/51-1282 · Telefax +49 (0) 7836/511440
E-Mail: info@hansgrohe.com · Internet: www.hansgrohe.com

05/2021
9.011489.06