

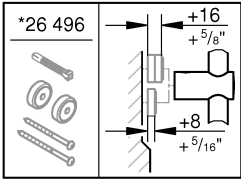

Y	47 728	47 984	49 056
Z	47 728	47 984	47 985 (F) 47 981 47 982 (F)

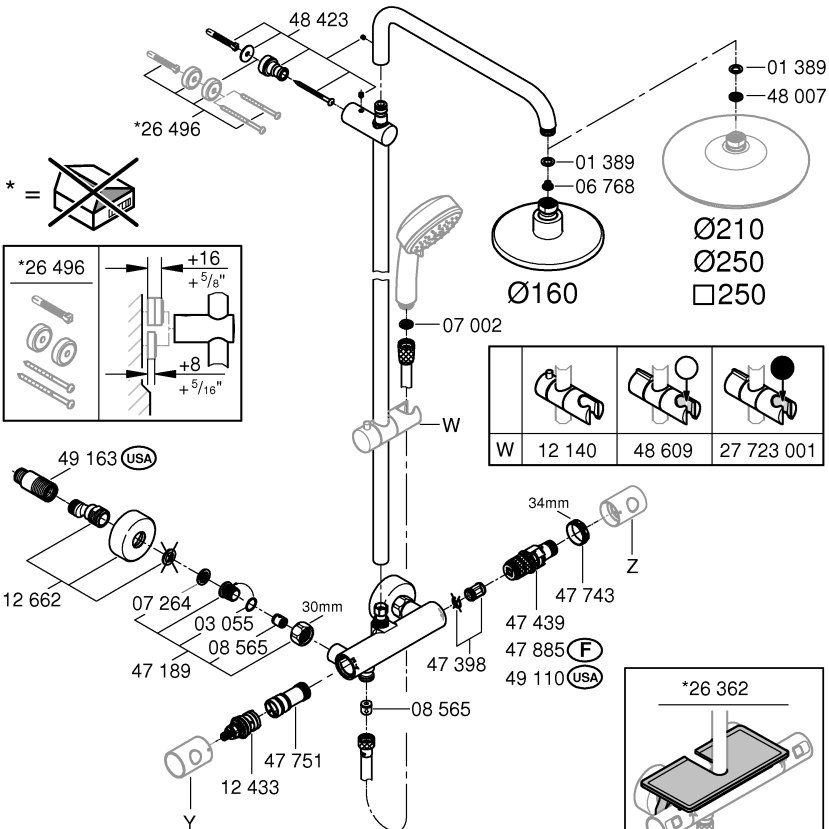

W	12 140	48 609	27 723 001

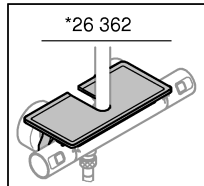

*19 377	30mm	*19 332	34mm	47 439 47 885 49 110	
				*47 175	



DIN EN
806

DIN
1988

DIN EN
1717



bar

max. 0,5 10 5 1

psi

max. 7,25 145 72,5 14,5

°C

max. 70° 60°

°F

max. 158° 140°

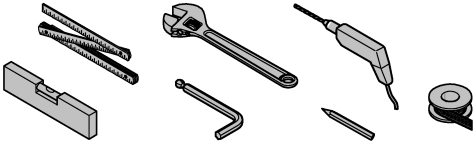
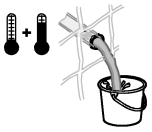

*19 001 34mm *19 377 30mm

*19 332

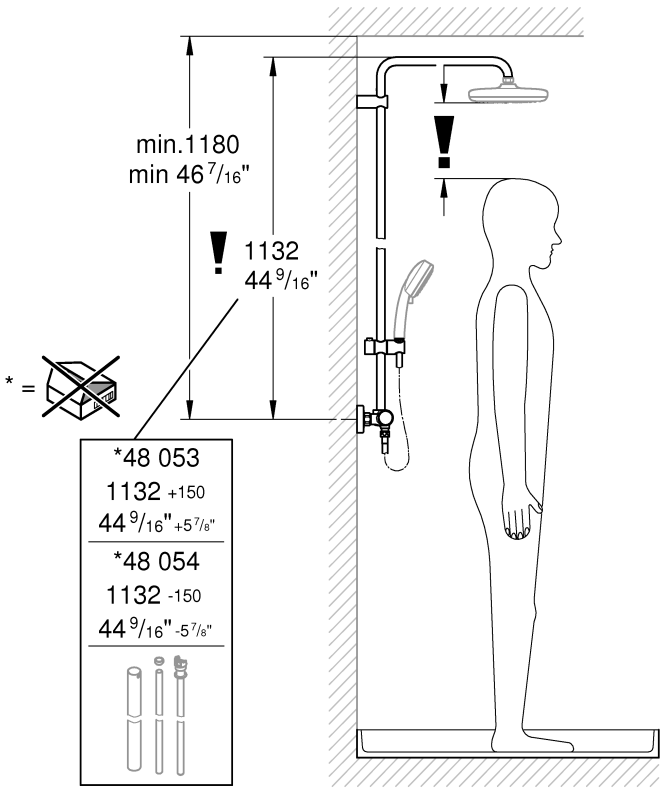



1a

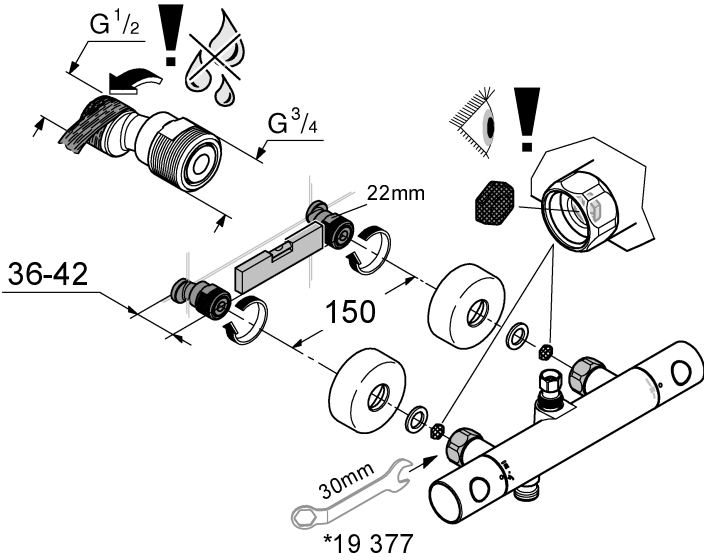

1b

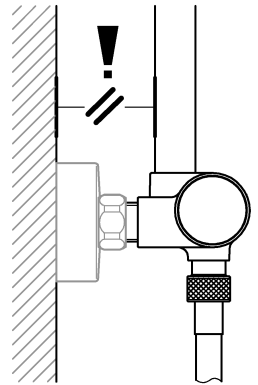
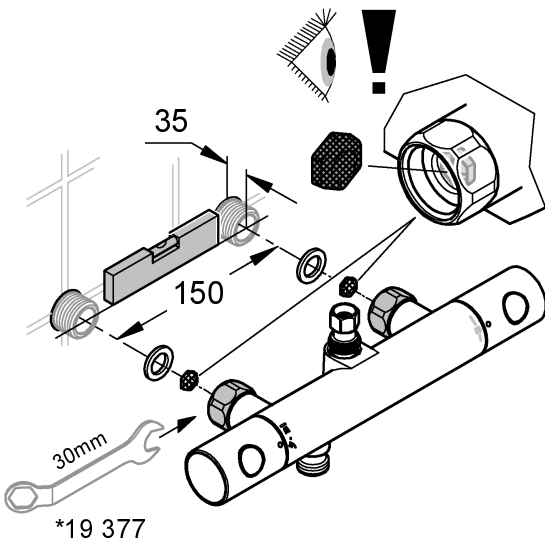



1c

USA

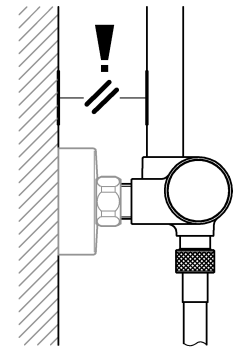
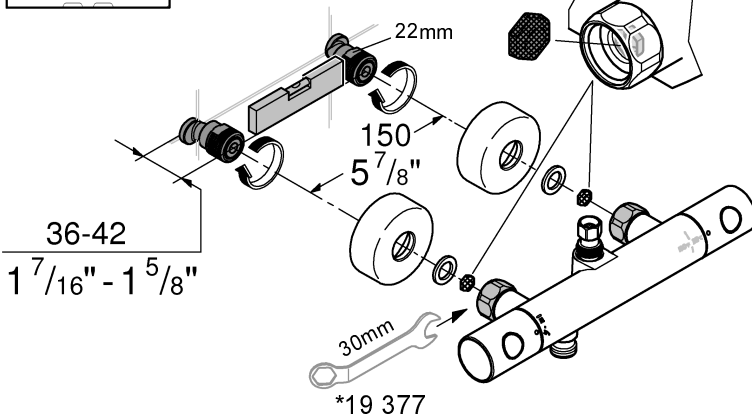
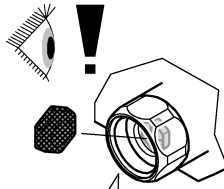
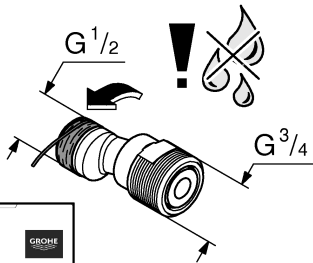
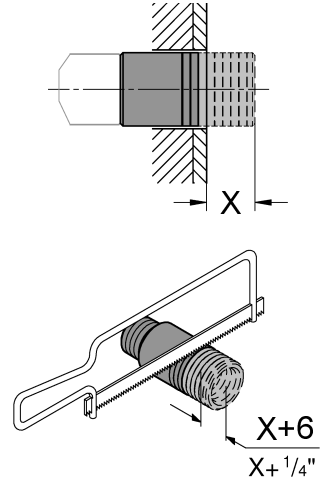
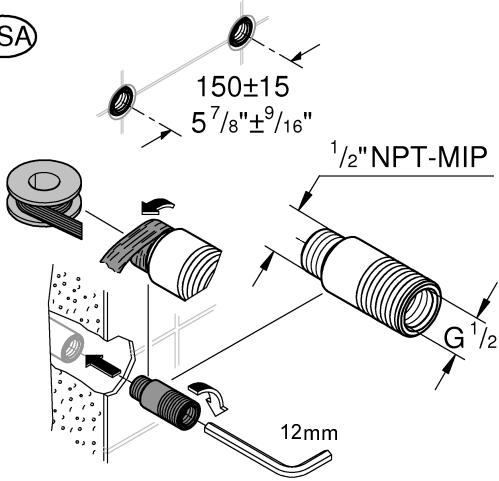

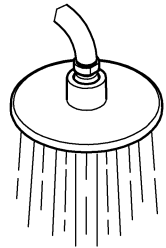
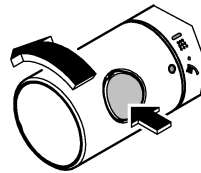
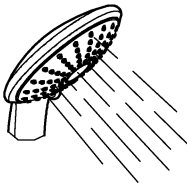
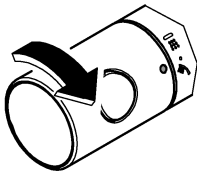
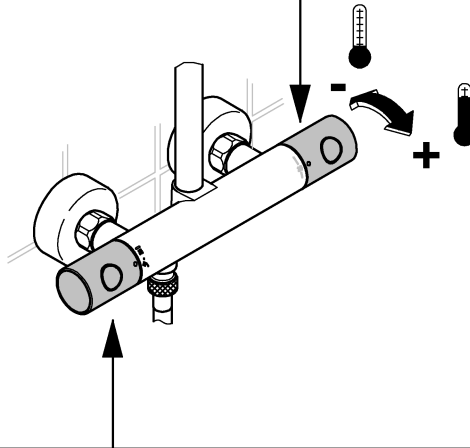
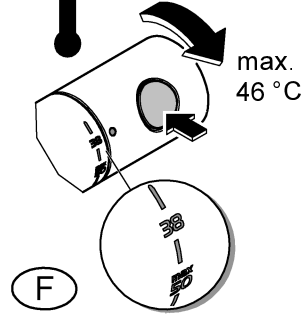
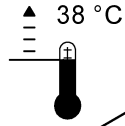
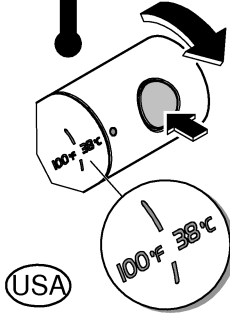
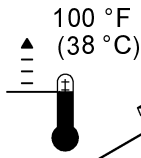
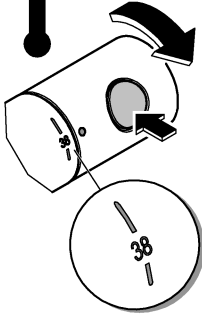
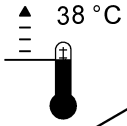



1

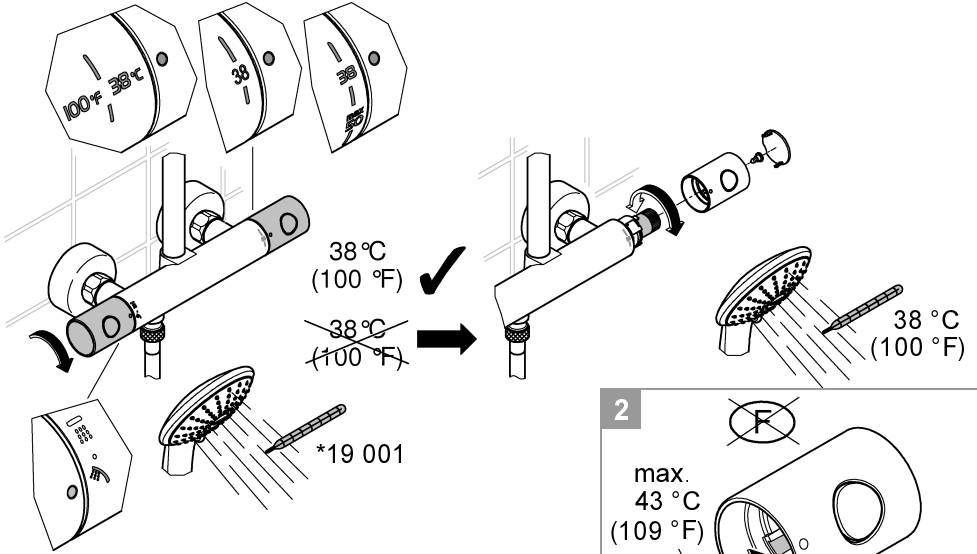

2

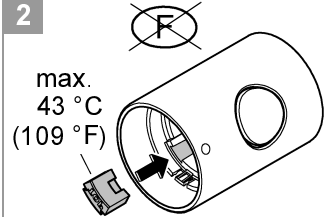

MAINTENANCE 

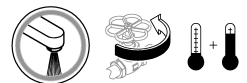
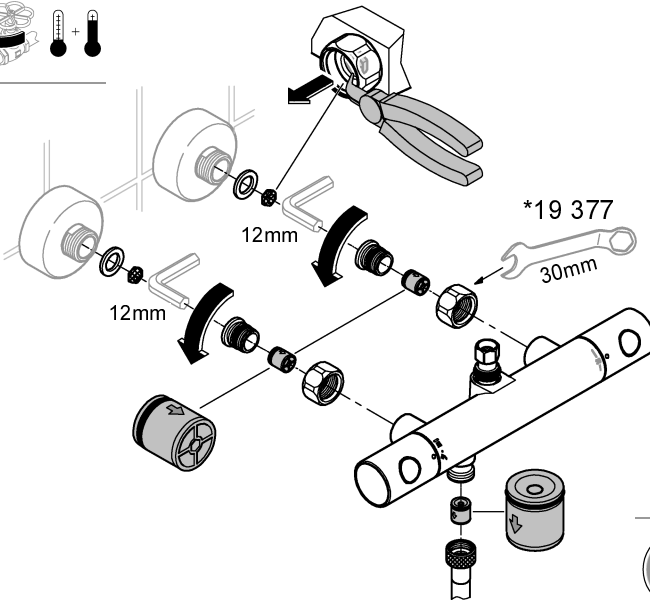

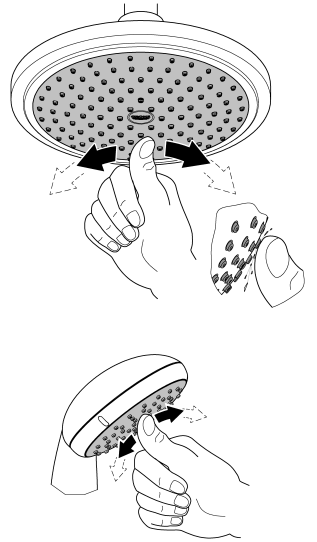
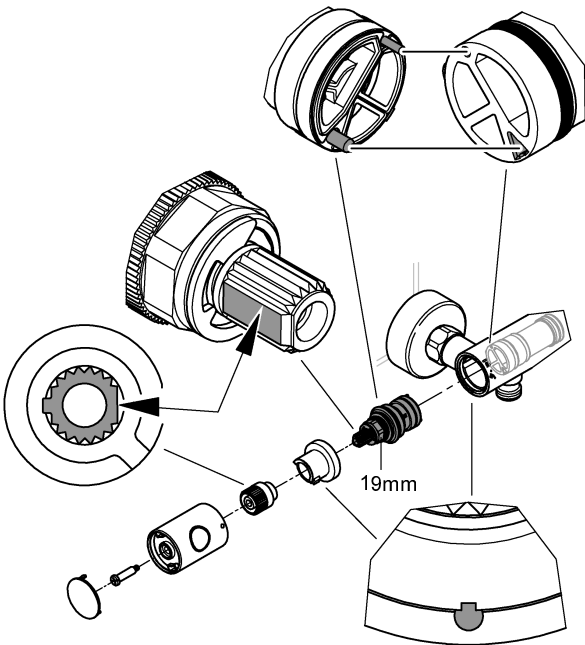
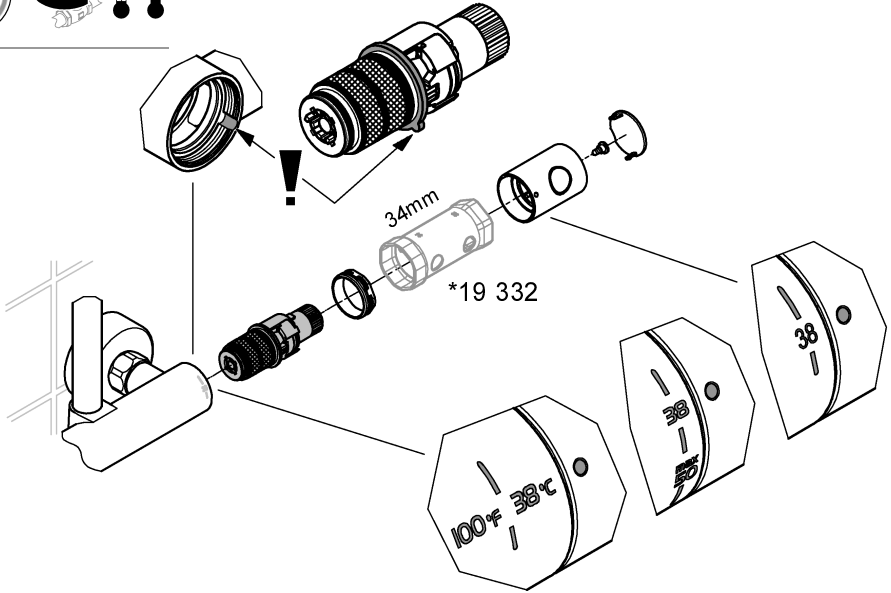

GB

Safety notes



Protection against scalding

It is recommended that near points of discharge with particular sensitivity to the outlet temperature (hospitals, schools, nursing and retirement homes) thermostatic devices should be installed which can limit the water temperature to 43 °C. The product includes an appropriate temperature end stop. It is generally recommended that the temperature of shower-systems should not exceed 38 °C in nurseries and specific areas of care centres. Use Grotherm Special thermostats with special handle to facilitate thermal disinfection and appropriate safety end stop. Applicable standards (e. g. EN 806-2) and technical regulations for drinking water must be observed.

Application

Thermostat mixers are designed for hot water supply via pressurised storage heaters and, utilised in this way, provide the best temperature accuracy. With sufficient power output (from 18 kW or 250 kcal/min), electric or gas instantaneous heaters are also suitable.

Thermostats **cannot** be used in conjunction with non-pressurised storage heaters (displacement water heaters).

All thermostats are adjusted in the factory at a flow pressure of 3 bar on both sides.

Should temperature deviations occur on account of special installation conditions, the thermostat must be adapted to local conditions (see Adjusting).

Specifications

Safety stop 38 °C
Hot water temperature at supply connection min. 2 °C higher than mixed water temperature
Thermal desinfection possible
Minimum flow rate = 5 l/min
If static pressure exceeds 5 bar, a pressure reducing valve must be fitted.



Installation

Reversed connection (hot on right - cold on left).

Replace thermostatic compact cartridge, see

Replacement parts, Prod. no.: 47 175 (1/2").

Installation of the shower rail

When installing e.g. on plasterboard walls (not solid walls) it must be assured that an appropriate reinforcement is in place to ensure sufficient strength.



Operation

The safety stop limits the temperature range to 38 °C.

The 38 °C limit can be overridden by pressing the button, see page 6.



Adjusting

Temperature adjustment, see page 7 Fig. [1].

Temperature end stop

If the temperature end stop is at 43 °C, insert accompanying temperature limiter in temperature selection handle, see Fig. [2].

Prevention of frost damage

When the domestic water system is drained, thermostat mixers must be drained separately, since non-return valves are installed in the hot and cold water connections. For this purpose, the mixer must be removed from the wall.



Maintenance

Inspect and clean all parts, replace if necessary and lubricate with special valve grease.

Shut off the hot and cold water supply.



Thermostatic compact cartridge, see page 8.

Readjustment is necessary after every maintenance operation on the thermostatic compact cartridge (see Adjusting).



Showers, see page 8.

The function of the SpeedClean nozzles is guaranteed for a period of five years.

Thanks to the SpeedClean nozzles, which must be regularly cleaned, limescale deposits on the rose can be removed by simply rubbing with the fingers.



Replacement parts

(* = special accessories).

Care

For directions on care, refer to the accompanying Care Instructions.