

STOUR Traditional Towel Rail Instructions

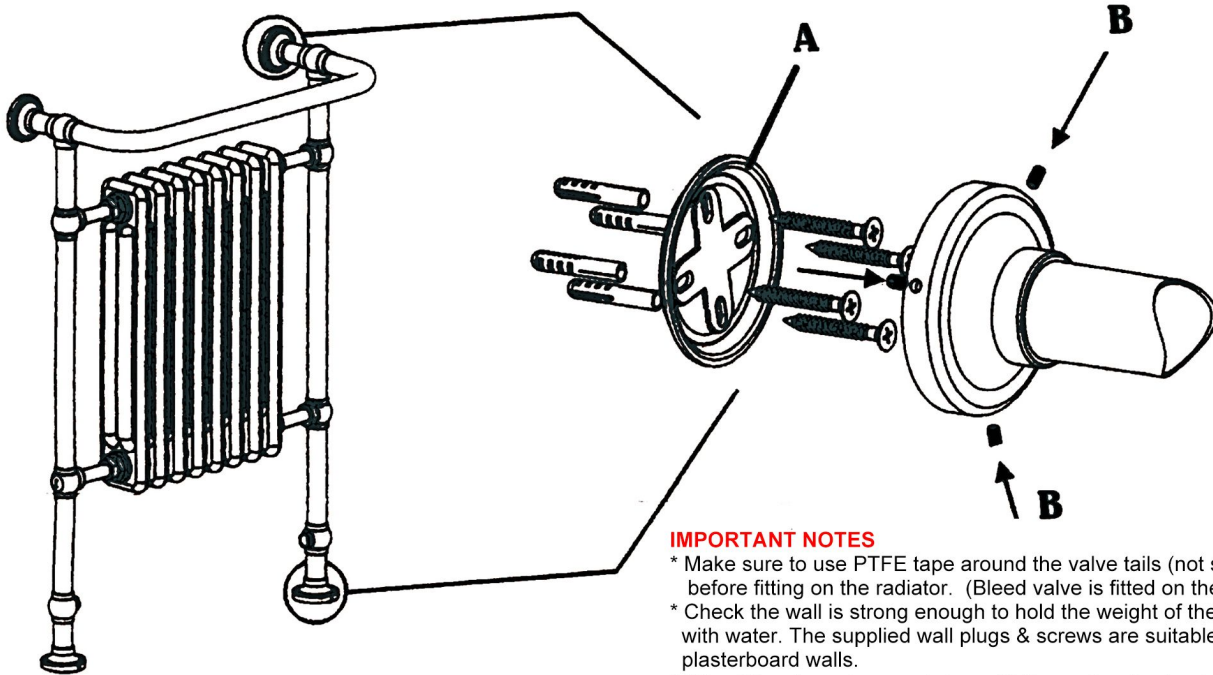

- This radiator has a built-in bleed valve and does not come with a blanking plug.
- The element inlet is located at the side of the bottom right tube.

IMPORTANT NOTES

- * Make sure to use PTFE tape around the valve tails (not supplied with the radiator) before fitting on the radiator. (Bleed valve is fitted on the radiator)
- * Check the wall is strong enough to hold the weight of the radiator that will be filled with water. The supplied wall plugs & screws are suitable for solid brick walls, not plasterboard walls.
- * After fitting the valves and plugs, fill the system to check for leaks.
- * Run the central heating system and release any trapped air using the air vent (bleed valve) plug.
- * It is not advisable to over tighten the wall plates to the wall / floor since this will eliminate a feature designed to overcome unevenness in the wall / floor surface. The wall / floor plate should be tightened only to the point where there is a gap between the plate and the wall / floor of 1/16". This will allow the grub screws to penetrate fully to the rear of the plate and as they are tightened, the whole installation will become tight and secure.
- * Please note that there is an electrical earthing point at the rear of the top right hand wall plate.

INSTALLATION

- This product must be installed by a fully qualified engineer.
- Please consider using an Eastbrook Valve Set - this will ensure that your radiator looks its best with matching radiator valves.
- On commissioning, flush the central heating system thoroughly using a proprietary solution to ensure that aggressive substances such as fluxes and manufacturing residue, from which internal surfaces of your radiator can sustain irreparable damage - are removed. It is further recommended that an appropriately approved corrosion inhibitor be subsequently added to the heating system in order to protect the radiator and other parts of the central heating system to promote extended operating lifespan. Please ensure, when adding inhibitor, not to underdose or overdose and follow the inhibitor instructions. **The Ph level** of the system water should be between 6.5 and 7.5 *If the system water is too acidic then the metals in the system would corrode. If the system water is too alkaline, then there is a higher risk of electrolysis.*

MAINTENANCE

- From time to time it is advisable to clean your radiator with a warm damp cloth. Never use any form of abrasive cleaner or chemical.
- Corrosion inhibitor must also be regularly maintained, please consult your heating engineer for details.

IMPORTANT

- Maximum working pressure of this radiator is 4 bar.
- This radiator is to be used on Domestic Central Heating systems only. (Not suitable for use on direct hot water systems). Please consult your heating engineer or supplier.

WARRANTY

Your Stour Towel Rail has five years manufacturer's warranty in respect of defective materials and workmanship and subject to installation being carried out by a qualified engineer in accordance with good practice and corrosion inhibitors being regularly maintained.

CONGRATULATIONS

You are the proud owner of an exclusive Stour Traditional Towel Rail which has been specially produced by our craftsmen who would wish you to enjoy many years of satisfaction from it.

INSTALLATION

This product must be installed by a fully qualified engineer.

- Please consider using an Eastbrook Valve Set – this will ensure that your radiator looks its best with matching radiator valves.
- On commissioning, flush the central heating system thoroughly using a proprietary solution to ensure that aggressive substances such as fluxes and manufacturing residue, from which internal surfaces of your radiator can sustain irreparable damage – are removed. A specifically approved inhibitor needs to be subsequently added to the heating system in order to protect the radiator and other parts of the central heating system to promote extended operating lifespan. Please ensure, when adding inhibitor, not to underdose or overdose and follow the inhibitor instructions. The Ph level of the system water should be between 6.5 and 7.5
The inhibitor must not be based nitrate based!
Do not used softened water in your radiator!
Beware of own brand inhibitors!
Eastbrook recommends FERNOX F1 or equivalent inhibitor for your radiators.

MAINTENANCE

- From time to time it is advisable to clean your towel rail with a warm damp cloth. Never use any form of abrasive cleaner or chemical.
- Corrosion inhibitor must also be regularly maintained, please consult your engineer for details.

IMPORTANT

- Maximum working pressure of this radiator is 4 bar.
- This radiator is to be used on Domestic Central Heating systems only. (Not suitable for use on direct hot water systems). Please consult your engineer or supplier.

WARRANTY

Your Stour Traditional Towel Rail has a manufacturer's warranty for five years in respect of defective materials and workmanship and subject to installation being carried out by a qualified engineer in accordance with good practice and the appropriate corrosion inhibitor being regularly maintained.

REMEMBER Excellence is worth looking after.