

CONTACT DETAILS

UK: Croydex, Central Way, Andover, Hampshire, SP10 5AW, UK

EU: MIL, Unit 8 Purcellsinch Ind Est, Dublin Road, Kilkenny, R95 HP71, Ireland

Tel: +44 (0)1264 365 881

Email: info@croydex.co.uk

Web: www.croydex.co.uk



ALWAYS CHECK THE PACKAGING FOR FIXINGS AND PARTS BEFORE THROWING AWAY AND RECYCLING.

ENSURE YOU HAVE ALL THE FIXINGS AND PARTS BEFORE ATTEMPTING TO ASSEMBLE OR FIT THIS PRODUCT.

- Always follow the instructions provided to ensure that your product is assembled and fitted safely, and retains its high quality finish.
- Before attempting to fit or use this product, ensure that it can be properly installed in the desired location.

ALWAYS RETAIN THIS MANUAL FOR FUTURE REFERENCE

SAFETY & PRODUCT CARE

1. To retain the best quality finish, clean product with a soft cloth and a mild soap solution applied directly to the cloth.
2. **DO NOT** use abrasive or chemical cleaners as they may damage the surface of the toilet seat or hinges.
3. **DO NOT** force the seat down or closed as this can cause damage to the product and its function.
4. **DO NOT** force open the seat beyond its mechanical limit before fitting it. This will damage the product.
5. **DO NOT** open the lid and ring before mounting on the toilet pan.
6. Ensure the seat is still locked in place after cleaning. In some instances, the quick release button may be activated when cleaning the toilet seat surface.
7. To remove the Adhesive Plate at the end of its use, use a plastic scraper to carefully lever the plate away from the toilet pan.

HINGE PACK

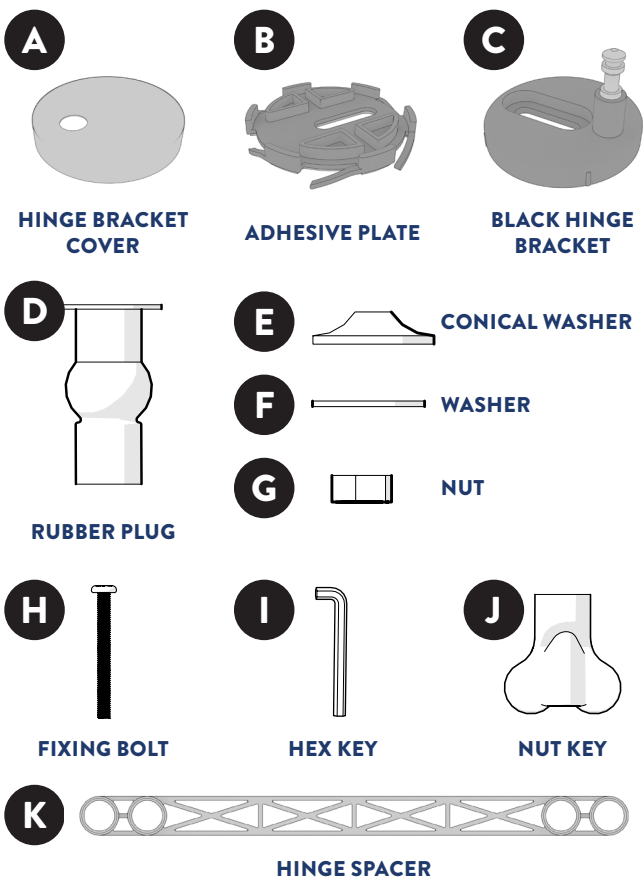

INSTALLATION

1. Remove the old seat from the pan and clean the surface around the fixing holes.
2. Ensure the surfaces around the fixing holes are completely dry and free of any dust or debris before beginning the installation.
3. To ensure you do not lose any dropped components in the toilet pan, place cling film over the toilet bowl.
4. **COMPLETE STEPS 4, 5 & 6 BEFORE REMOVING THE HYGIENE FILM** from the toilet seat. Position the seat over your pan to ensure the shape and profile of the toilet seat matches your toilet pan. (See Fig. 1)
5. Align the front edge of the toilet seat with the front of your toilet pan. Hold your hand at the back of the toilet seat and using it as a pivot, raise the toilet seat. (See Fig. 2)

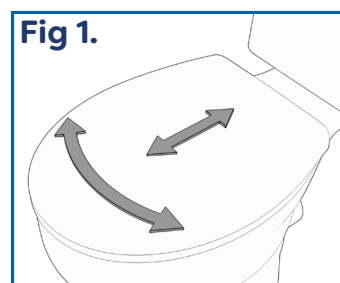

6. The seat should be able to rest backwards at an angle. If it cannot rest at an angle and can only rest vertically. The seat **WILL NOT** function correctly. (See Fig. 3A & 3B)

7. ONLY AFTER YOU ARE SATISFIED THAT THE TOILET SEAT WILL FIT YOUR TOILET PAN SHOULD YOU REMOVE THE HYGIENE FILM.

8. Press together the Hinge Plate assembly. Ensuring the slots are correctly aligned. (See Fig. 4)

9. Carefully peel off the red backing tape from the adhesive pad on both Hinge Plate assemblies. (See Fig. 5)

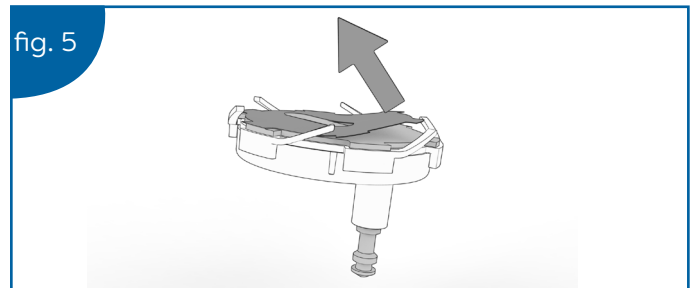
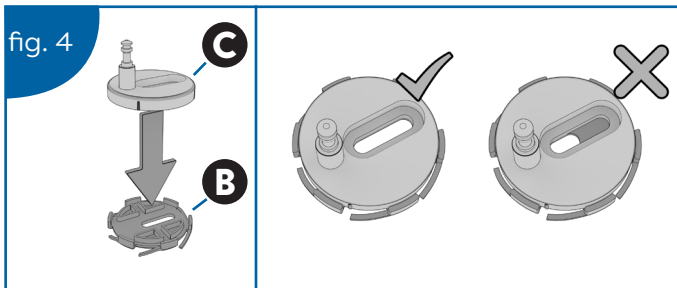
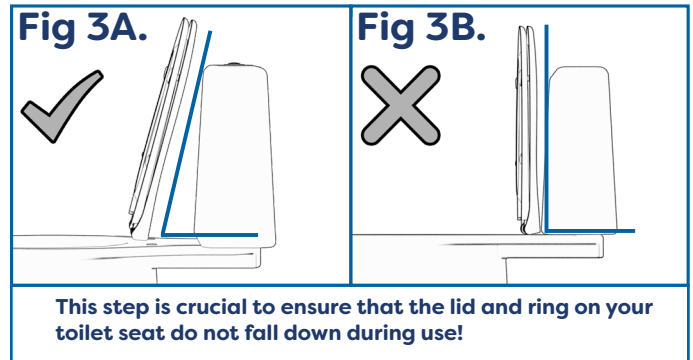

10. Identify your toilet pan style, see the images below.

LOOSELY INSTALL BOTH HINGE BRACKETS through the mounting holes using either bottom fix installation (See Fig. 6) **OR** top fix installation (See Fig. 7)

DO NOT COMPRESS THE HINGE BRACKETS, THIS MAY RESULT IN THE TAPE STICKING BEFORE YOU ARE HAPPY WITH THE PLACEMENT OF THE TOILET SEAT!

CHOOSE BETWEEN

BOTTOM FIX INSTALLATION

This installation is designed for use on 'standard' toilets with access below the toilet pan. See below.



Examples of Bottom Fix toilet pans.

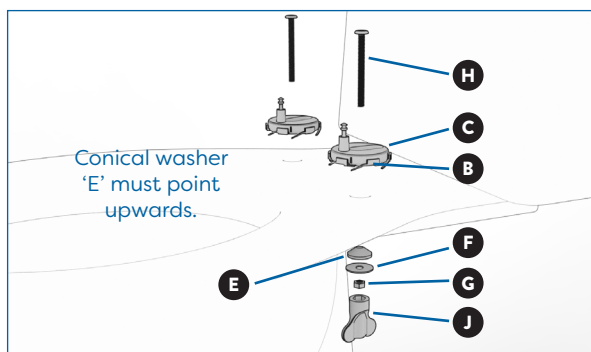

(Fig. 6)

TOP FIX INSTALLATION

This installation is designed to be used on 'back to wall' toilets with no access below the toilet pan. See below.



Examples of Top Fix toilet pans.

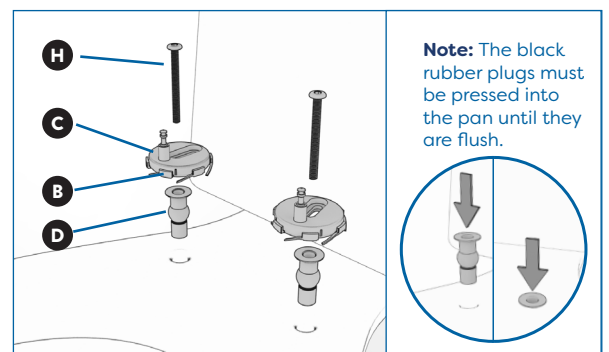

(Fig. 7)

OR

11. Slide the spacer onto both pillars using the inside pair of holes. Rotate the brackets if necessary. (See Fig. 8)

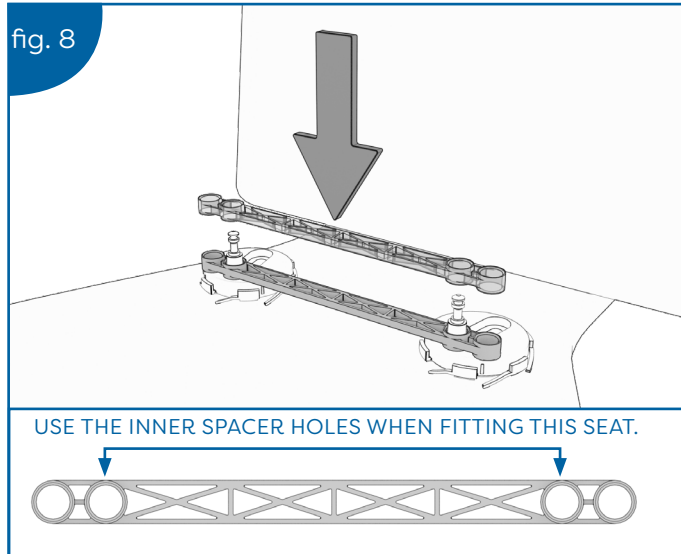

12. Attach the seat onto the hinges. **Do not apply downwards pressure onto the seat before you have adjusted the fit.** (See Fig. 9)

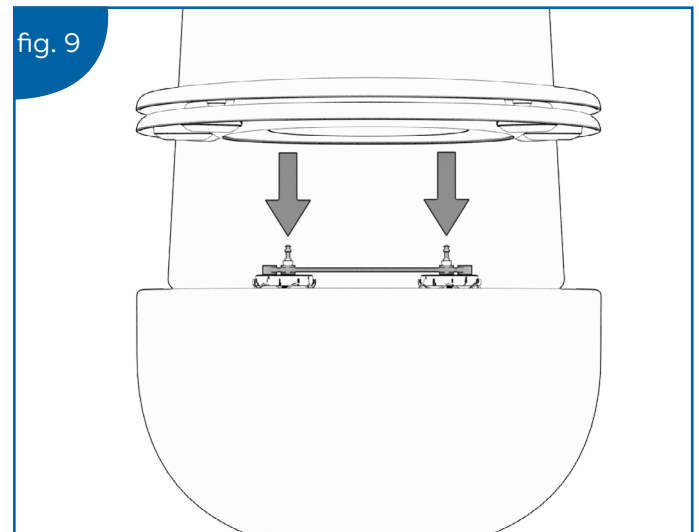

13. Adjust the seat position. **IMPORTANT! Ensure that the front buffers contact the seat. Be careful not to push down on the top of the seat.** (See Fig. 10)

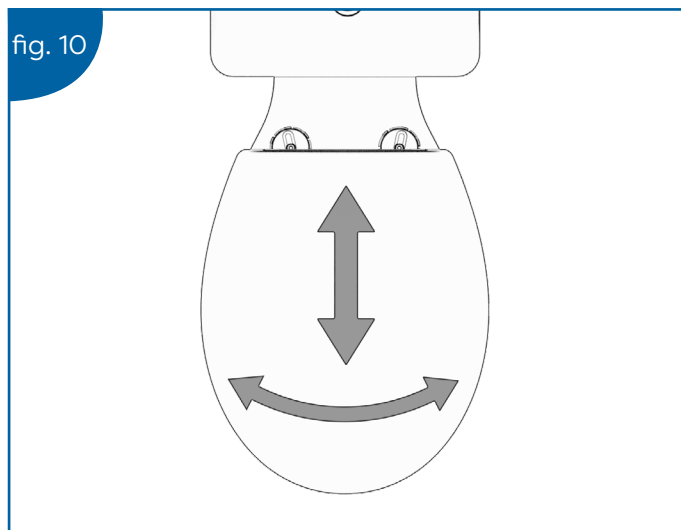

14. Once you are confident with the position of your seat, apply pressure to both hinge plates so the adhesive tape makes contact with the pan. **HOLD DOWN FOR 20 SECONDS** (See Fig. 11)

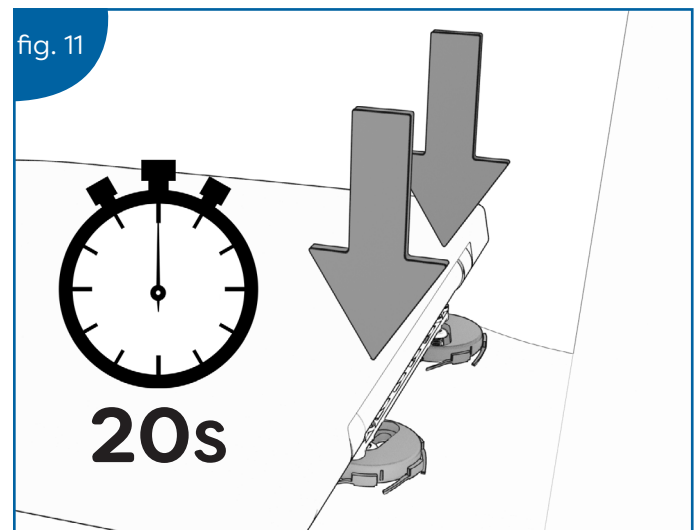

15. Remove the seat **without moving the hinge brackets** and fully tighten the bolts to firmly secure them in position. If the spacer blocks access to the fixing bolts, ensure the brackets are firmly adhered to the pan then **carefully** remove the spacer and tighten the bolts. **DO NOT OVERTIGHTEN!** (See Fig. 12 & 13)

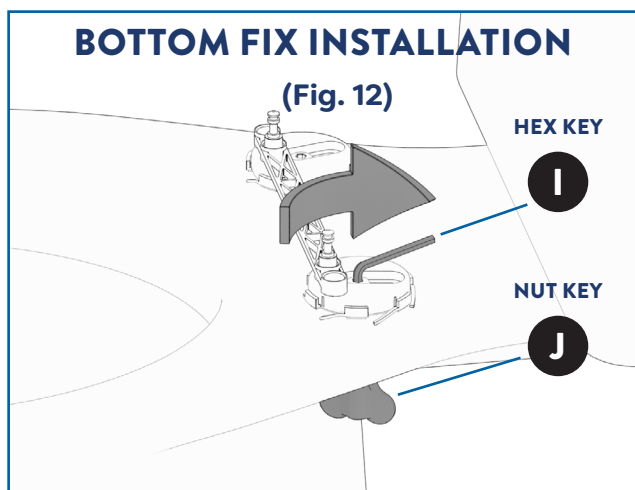

OR

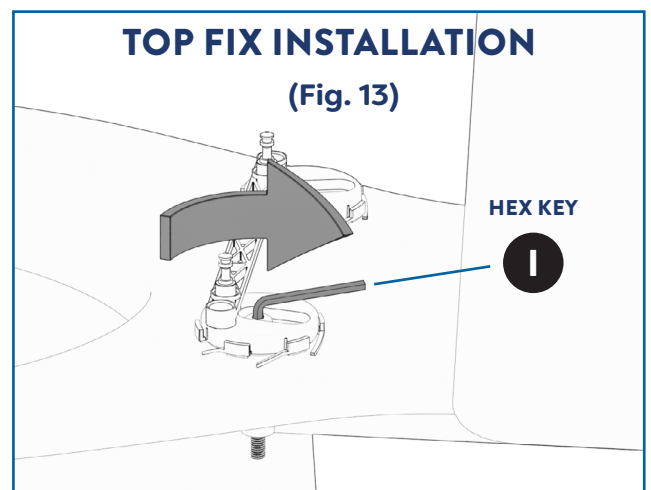

16. If you have not done so in the previous step, remove the spacer from the hinge brackets. (See Fig. 14)

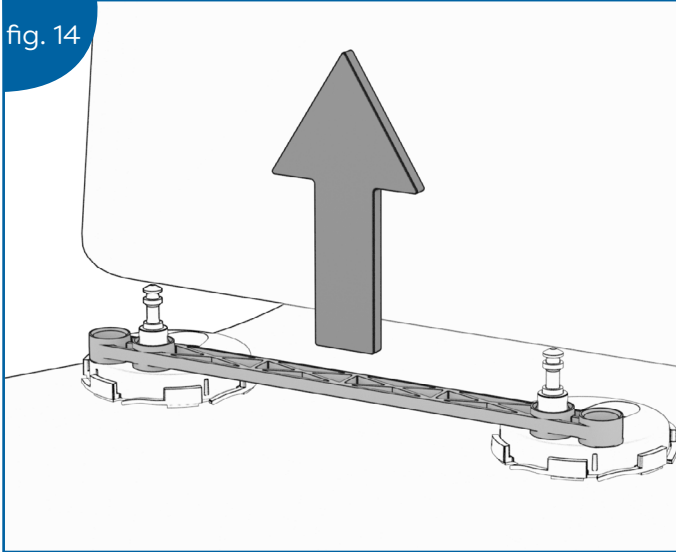

17. Place the stainless steel hinge bracket covers over the brackets, ensure they sit flush with the surface of the pan. (See Fig. 15)

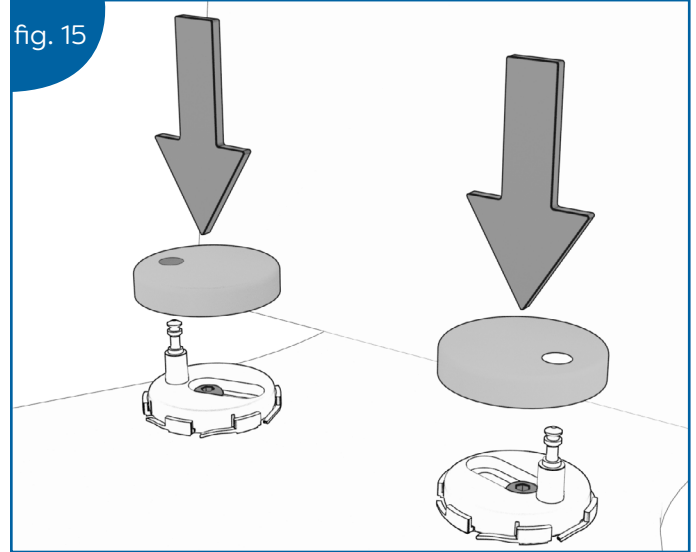

18. Attach the seat onto the hinges to complete the installation. You will hear an audible click to confirm it is engaged. (See Fig. 16)

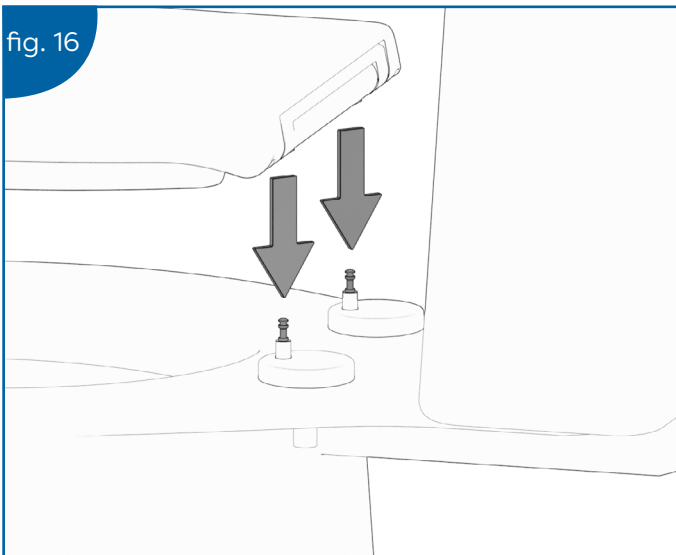

19. To activate the quick release function, press in the button once, then lift the seat away. **When cleaning, ensure that this button is not accidentally activated.** See point 4 in “Safety & Product Care”. (See Fig. 17)

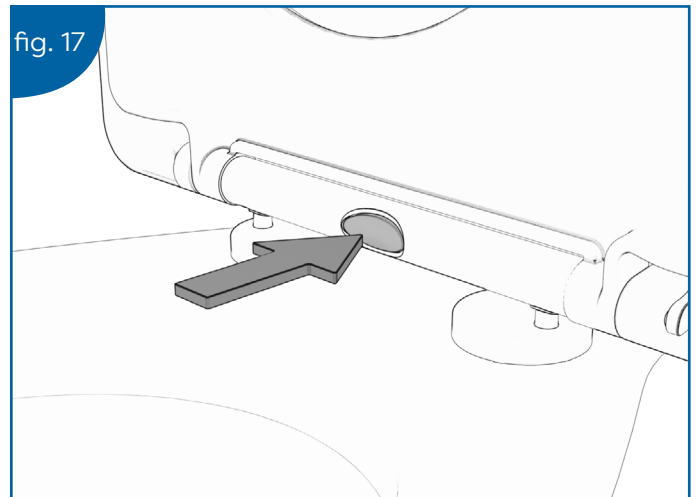

20. If applicable, to remove the smaller seat ring. Clip it away from either side of the hinge barrel. To refit, simply reverse this process. (See Fig. 18)

