

BRISTAN

Installation Instructions & User Guide

Please leave these instructions
with the end user

Product Code: CRU 3TH WMBF Range (D2)

Specification

Dynamic Water Pressure

Min: 1 bar Max: 5.0 bar



Maximum Static Pressure: 10.0 bar

Inlet Water Temperature

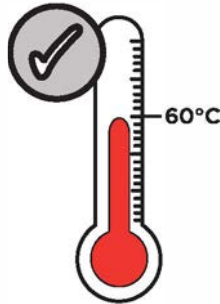

Maximum Hot: 60°C

Inlet Connections

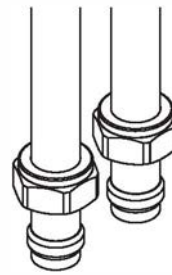

15mm Compression

Outlet

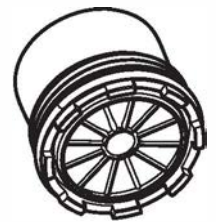

Recessed M18.5
Flow Straightener

Pack Contents

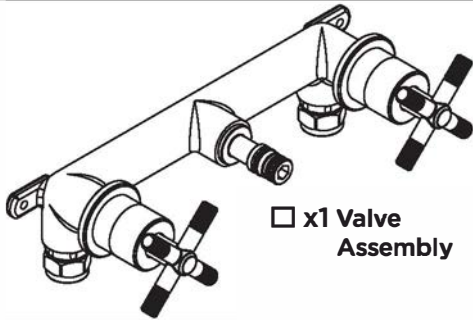

☐ x1 Valve
Assembly

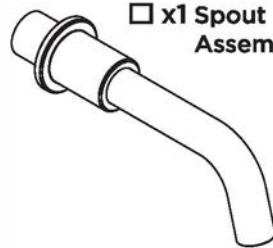

☐ x1 Spout
Assembly

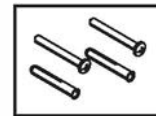

☐ x1 Wall Fixings

Operation

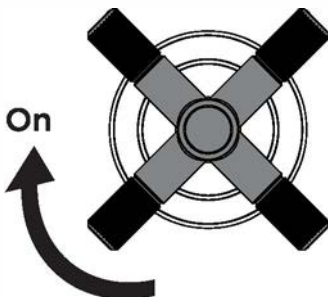

Hot

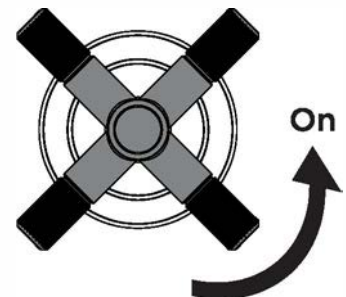
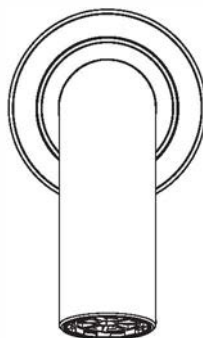

Cold

Tools Required



Cross Head
Screwdriver



Drill

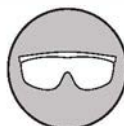

Safety
Goggles



Electronic
Detector



Spanner



Hex Key



Hex Key



Box
Spanner

Prior to Installation

All products manufactured and supplied by Bristan are safe to use provided that they are installed, operated and receive regular maintenance in accordance with these instructions.

This product needs to be installed in accordance with, and meet the requirements of The Water Supply (Water Fittings) Regulations (Northern Ireland) 2009 and The Water Supply (Water Fittings) (Scotland) Byelaws 2014.

For full Installation Requirements & Notes (IRN) please visit www.wrasapprovals.co.uk/approvals-directory

Isolation valves must be fitted to the inlet water supplies to ensure ease of future maintenance. Before installing this product the water supply must be thoroughly flushed in order to remove any swarf, solder etc. Full access must be made available for future maintenance/servicing purposes.

If power tools are used do not forget to:

- Wear eye protection
- Unplug equipment after use

This product must not be modified in any way as this will invalidate the guarantee.

Typical Installation

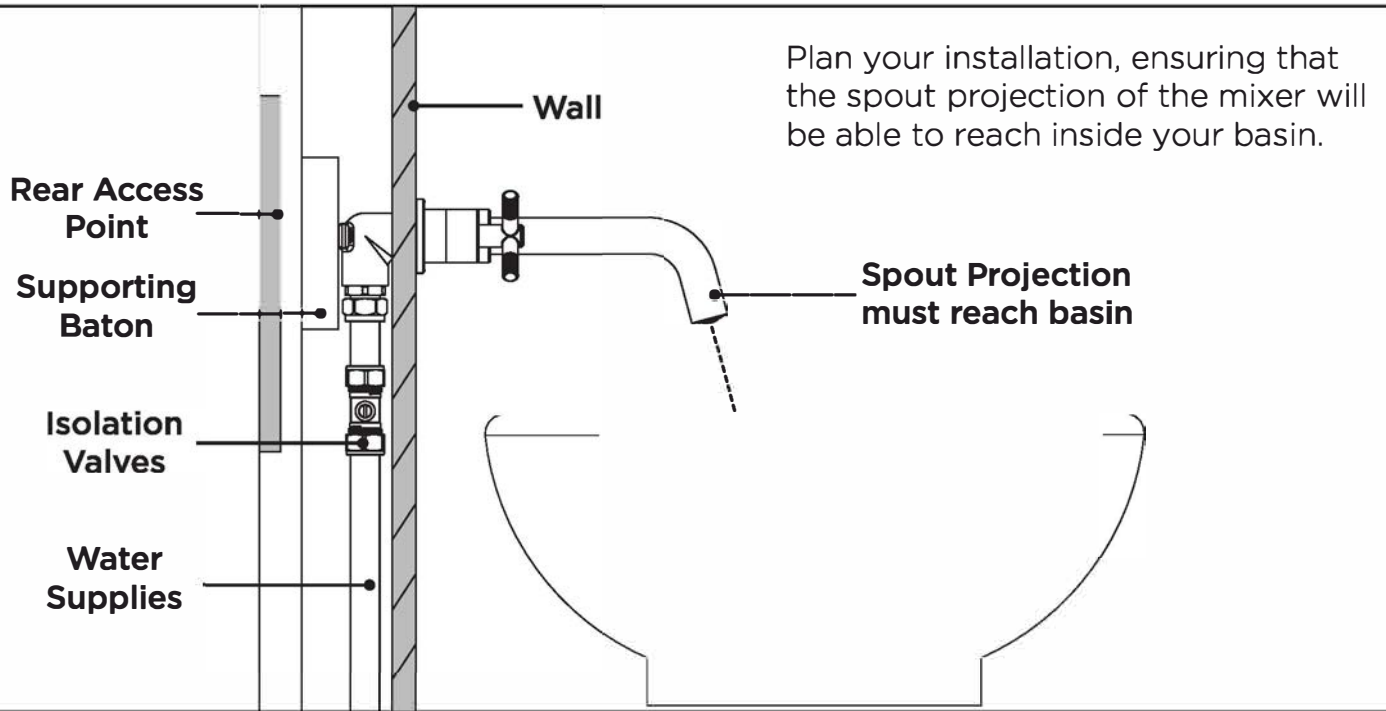

Critical Dimensions

Please ensure that the installation and accommodation is designed with future serviceability of the product in mind. Rear access will also be required in order to access the valve for future maintenance/re-fitting purposes. It is strongly advised to fit isolation valves to the water fixtures in an easy to access location; in case isolation is required at any point during maintenance.

In the event a future claim is made under the product warranty, the design of the installation may affect compensation costs if it has not been considered in the original design. Failure to observe crucial information in these fitting instructions will nullify your guarantee.

This product requires experience within plumbing. No responsibility will be taken for poor workmanship resulting in leaks and injuries.

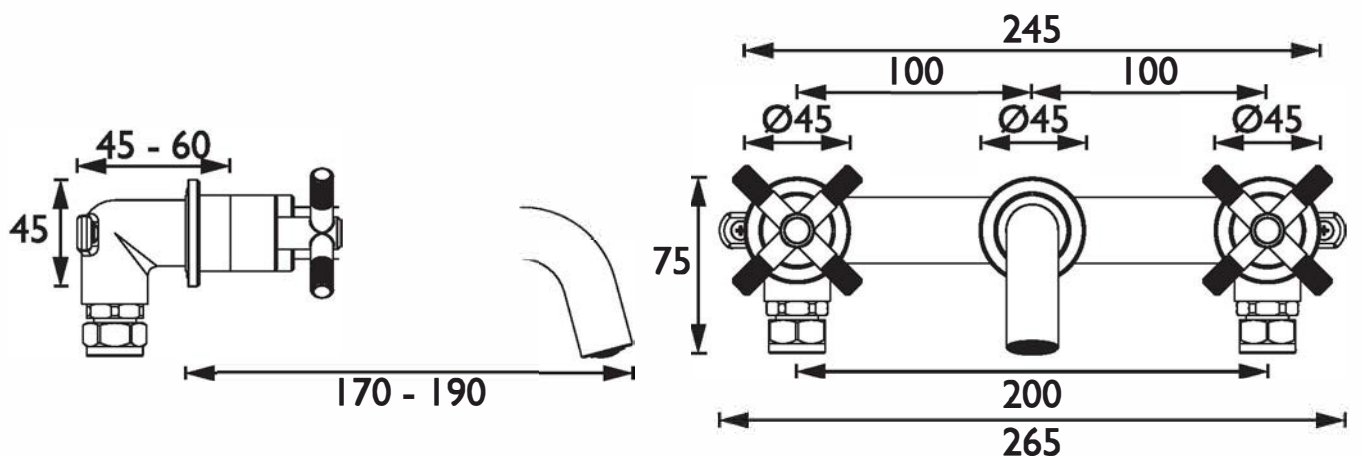

Installation

3

Rear Access Point

Measure the cavity depth and allow for a sufficient amount of the valve to protrude through the wall for fitting.

Baton

Front Cut-Out

Install suitable batons if necessary to secure the valve.



REMEMBER

Refer to the Critical Dimensions Allow for the wall finish when measuring!

4

Mark and drill the fixing holes.

Secure the valve body using suitable fixings for your wall type.

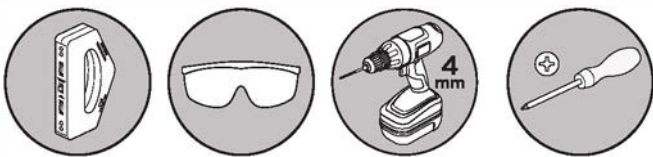

5

Plumb the hot and cold water supplies to the valve body using the nut and olives.

Hot

Fit isolation valves (not supplied) as close as possible to the valve body.

24 mm

Cold

Turn on the water supply and check all joints for any leaks.

6

Finish the wall, then push the spout on to the spout fitting.

Tighten the grub screws on the sides to secure the spout.

2 mm

Installation - Continued

7

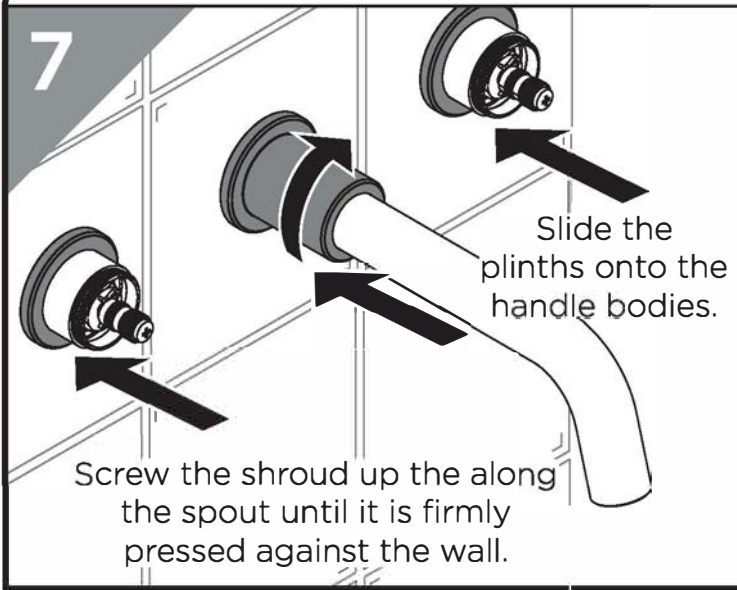

Slide the plinths onto the handle bodies.

Screw the shroud up the along the spout until it is firmly pressed against the wall.

8

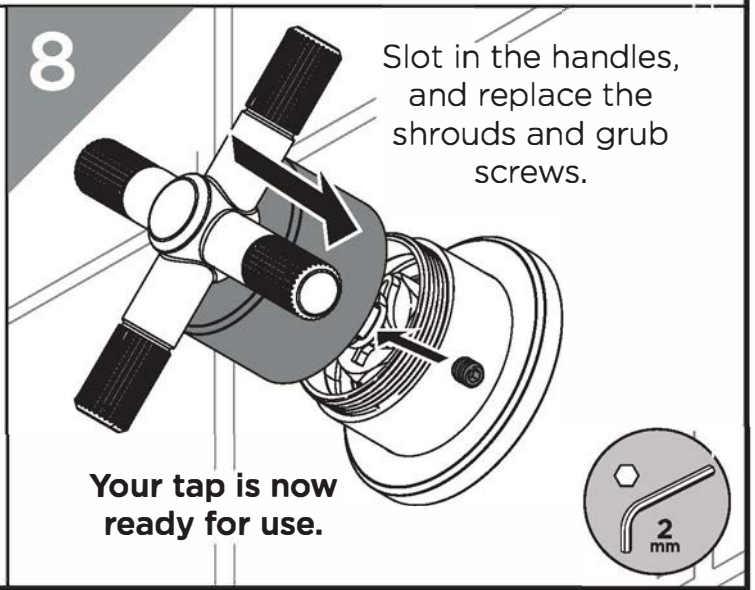

Slot in the handles, and replace the shrouds and grub screws.

Your tap is now ready for use.

2 mm

Maintenance - Valve Replacement

1

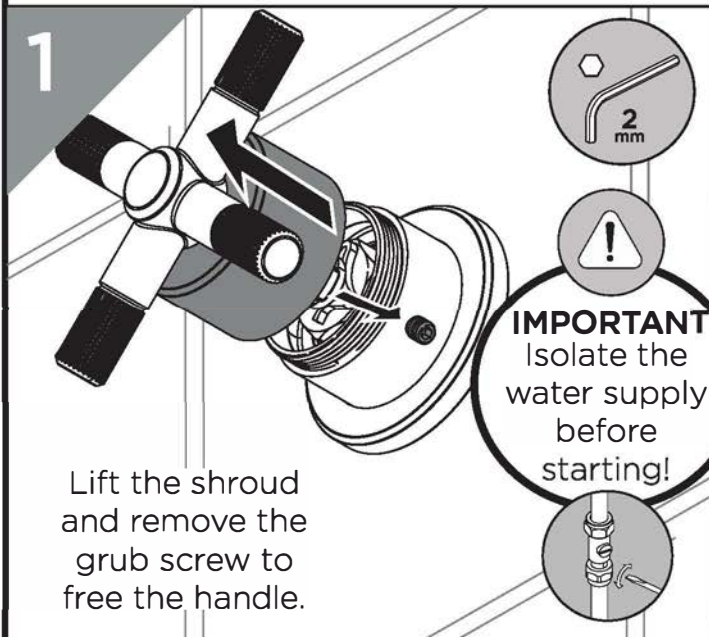

Lift the shroud and remove the grub screw to free the handle.

2 mm

IMPORTANT
Isolate the water supply before starting!

2

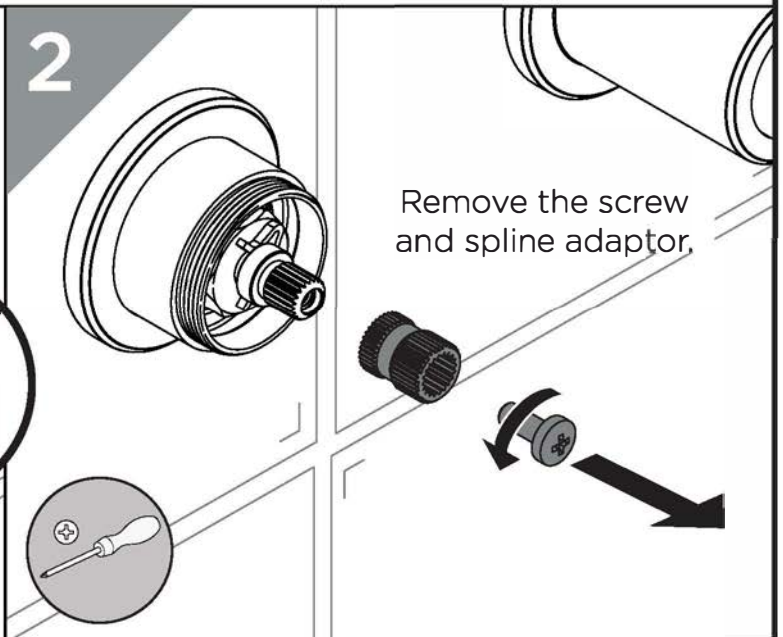

Remove the screw and spline adaptor,

3

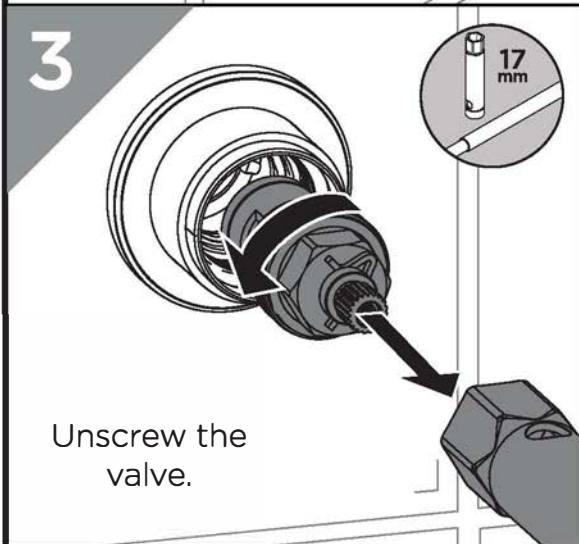

Unscrew the valve.

17 mm

4



For replacement valve, scan the QR Code or visit www.bristan.com and search for your product.

5

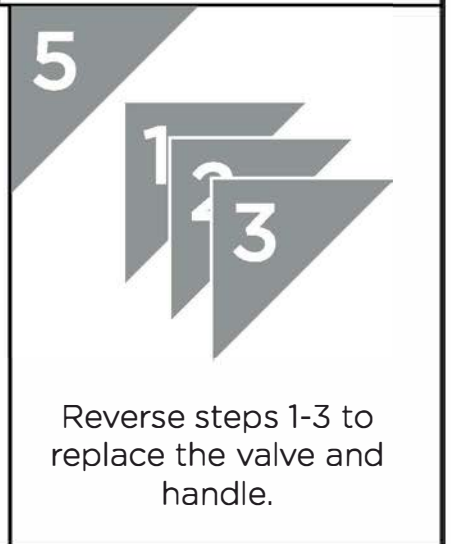

Reverse steps 1-3 to replace the valve and handle.

Maintenance - Outlet Cleaning



General Cleaning

Bristan products are made from premium materials, with hand polished, PVD, EPD or electroplated finishes. Your product should be regularly cleaned with warm water, a mild pH-neutral liquid soap, and polished with a soft cloth. Any residues from soap, toothpaste, shampoos and shower gels can cause blemishes if not rinsed off straight after use.

Household bleaches and cleaners contain harsh chemicals and may damage the surface finish. Avoid using abrasive cloths, scouring pads, scrub sponges, steel wool or anything similar.

Troubleshooting

Symptom	Cause	Remedy
Low Flow	Partially closed isolation valve.	Open isolation valve.
	Airlock or partial blockage in the supply pipework.	Flush through pipework to ensure removal of debris and any airlocks.
	Partial blockage in the outlet	Remove to Clean and soak in suitable solution.
No hot water or cycling hot and cold	Instantaneous water heater cycles on and off as flow rate or pressure is too low.	Increase water flow rate or pressure through system.
No Flow	Closed isolation valve.	Open isolation valve.
	Mains water supply turned off.	Turn on mains water supply.
Temperatures not corresponding with taps	Inlet pipes have been connected incorrectly	Swap the inlet tails around.

Spare Parts



To replace any spare parts for your tap, why not scan the QR Code or visit www.bristan.com and search for your product.

Contact Us

BRISTAN

Part of **BRISTAN GROUP**

Bristan Group Ltd.
A Masco Company

UK: Bristan Group,
Pooley Hall Drive,
Birch Coppice Business Park,
Dordon, Tamworth
B78 1SG.

EU: Masco Europe S.à.r.l.
14 Rue Strachen
6933 Mensdorf
Luxembourg

Email Us: enquire@bristan.com
Website: www.bristan.com
Call Us: +44330 026 6273

Our Guarantee

At Bristan, we want to make things as easy as possible for our customers. That's why we offer solid guarantees on all our products, effective from the date of purchase, to give you peace of mind.

To start your free guarantee simply scan the QR code and register your product.
Alternatively visit www.bristan.com/register.



For any other queries, please call our Customer Service on 0330 026 6273 where our expert team of advisors will be able to offer you any help and advice.

For full guarantee terms and conditions visit www.bristan.com/service-centre/guarantees.