



BRISTAN

Installation Instructions & User Guide

Please leave these instructions with the end user



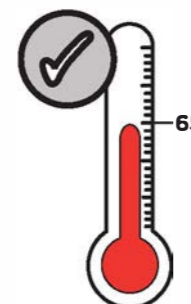
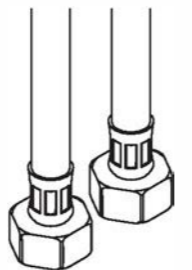

Product Code: CRU TBAS Range (D2)

Specification

Dynamic Water Pressure Min: 0.5 bar Max: 5.0 bar  Maximum Static Pressure: 10.0 bar	Inlet Water Temperature  Maximum Hot: 65°C	Inlet Connections  1/2" BSP Flexible Tails	Outlet  M18.5 5/16 inch Coin-Slot Aerator
---	--	---	---

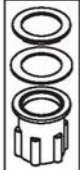
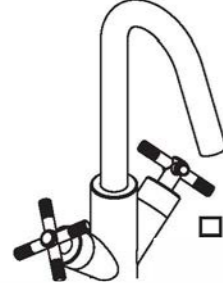
Pack Contents

Operation

-  x1 Fixing Kit
-  x1 Tall Basin Mixer
-  x1 Waste Assembly
-  x2 Flexible Tails
-  x1 Plinth and Rubber Seal

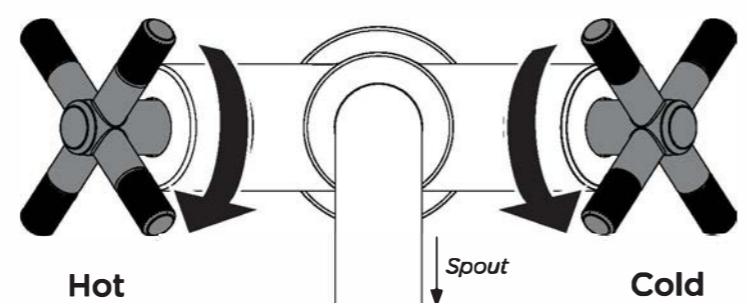

Tools Required

-  Cross Head Screwdriver
-  Adjustable Spanner
-  Socket Spanner 17 mm
-  Hex Key 8 mm
-  Hex Key 2 mm

Prior to Installation

Spare Parts

All products manufactured and supplied by Bristan are safe to use provided that they are installed, operated and receive regular maintenance in accordance with these instructions.

This product needs to be installed in accordance with, and meet the requirements of The Water Supply (Water Fittings) Regulations (Northern Ireland) 2009 and The Water Supply (Water Fittings) (Scotland) Byelaws 2014.

For full Installation Requirements & Notes (IRN) please visit www.wrasapprovals.co.uk/approvals-directory

Isolation valves must be fitted to the inlet water supplies to ensure ease of future maintenance.

Before installing this product the water supply must be thoroughly flushed in order to remove any swarf, solder etc. Full access must be made available for future maintenance/servicing purposes.

This product must not be modified in any way as this will invalidate the guarantee.



To replace any spare parts for your tap, scan the QR Code or visit www.bristan.com and search for your product.

 PLEASE NOTE - Taps shown in these instructions are for illustration purposes only. Your product can be installed and maintained using these instructions.

Installation

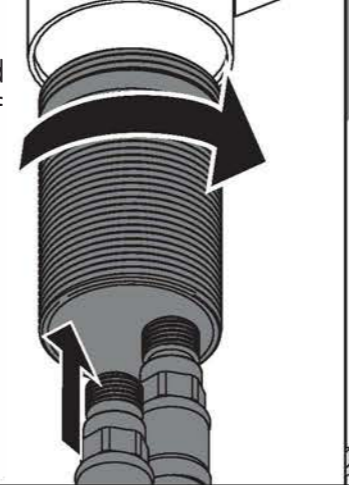
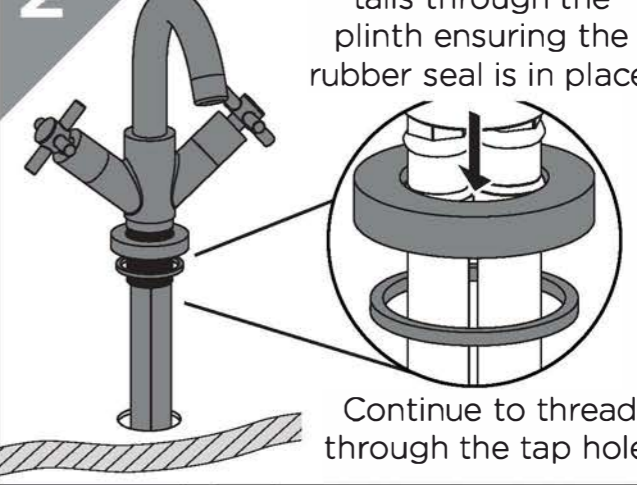
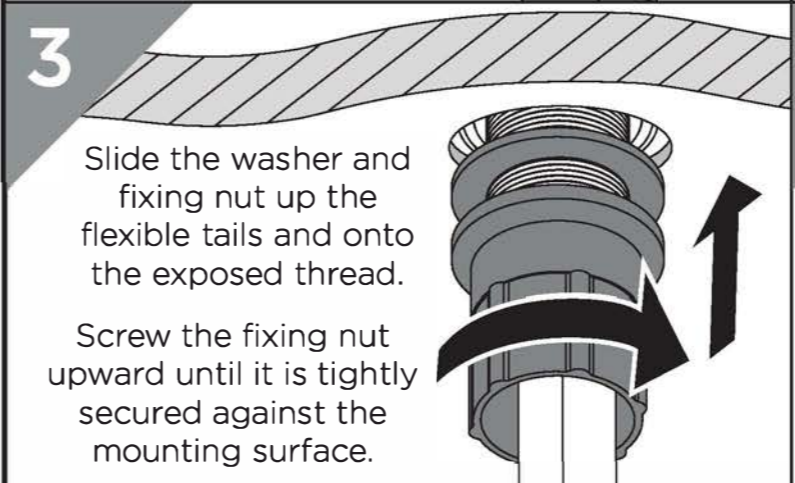
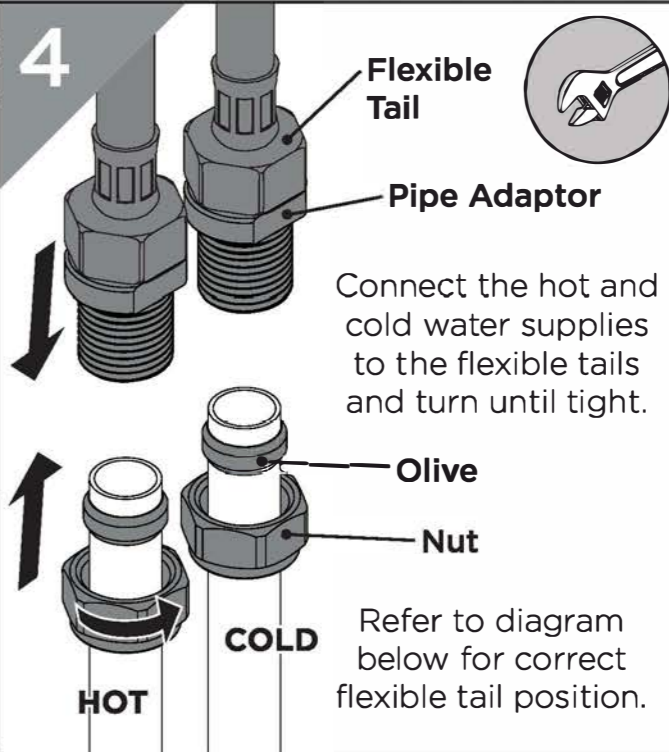
- 1** Screw the threaded tail into the base of the tap, ensuring the thread break is at the top.
 Screw in the flexible tails by hand only. **DO NOT OVERTIGHTEN**

- 2** Thread the tap and tails through the plinth ensuring the rubber seal is in place.
 Continue to thread through the tap hole.
 
- 3** Slide the washer and fixing nut up the flexible tails and onto the exposed thread.
 Screw the fixing nut upward until it is tightly secured against the mounting surface.
 
- 4** Connect the hot and cold water supplies to the flexible tails and turn until tight.
 

Flexible Tail

Pipe Adaptor

Olive

Nut

HOT

COLD

Refer to diagram below for correct flexible tail position.

Ensure flexible tails are positioned correctly.

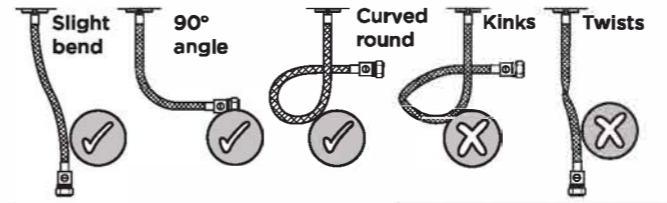

General Cleaning

Bristan products are made from premium materials, with hand polished, electroplated, PVD or EPD finishes.

Your taps or shower should be regularly cleaned with warm water, a mild pH-neutral liquid soap, and polished with a soft cloth. Any residues from soap, toothpaste, shampoos and shower gels can cause blemishes if not rinsed off straight after use.

Household bleaches and cleaners contain harsh chemicals and may damage the surface finish. Avoid using abrasive cloths, scouring pads, scrub sponges, steel wool or anything similar.

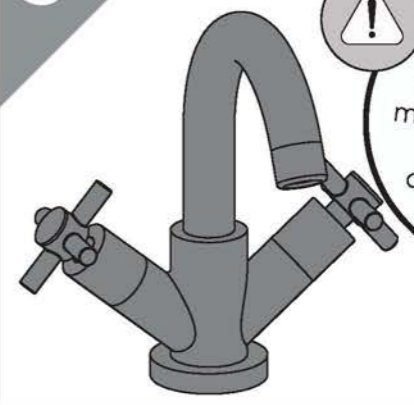
- 5**

IMPORTANT
Turn on water supply for a few minutes and check all joints and connections for any leaks.

Your tap is now ready for use.

Valve Maintenance - Isolate water supply before starting!

1 Pry off the handle to reveal the screw.
Remove the screw and washer to loosen the handle.

2 Lift off the handle and unscrew the shroud.

3 Unscrew and remove the valve.
For replacement cartridges, see **SPARE PARTS**.

4 Reverse steps to replace the cartridge.

Waste Installation and Operation

1 Thread the washer onto the waste until it sits tightly under the lip.
Push the waste into the hole until the lip sits flush with the basin.

2 Slide the second washer along the exposed underside of the waste.
Then tighten the backnut to secure in place.

3 Push the centre down to close the waste, push again to open.
Your waste is now ready for use.

Spout Seals Replacement

- Isolate water supply before starting!

1 Remove the grub screw from the rear of the tap and lift out the spout.

2 Unscrew the spout connector.
Take note of spout seal positions, then remove them.

3 Place the new seals kit onto the spout connector and screw back into tap body.

4 Replace the spout and grub screw.

For replacement seals kit, see **SPARE PARTS**.
Apply a WRAS approved grease to the new seals kit.

Outlet Cleaning

1 Insert a coin into the slot in the outlet and twist gently to remove.
(Reverse to replace)

2 Check all loose parts for damage and then soak using a suitable solution to de-scale.

Troubleshooting

Symptom	Cause	Remedy
Low Flow	Partially closed isolation valve.	Open isolation valve.
	Airlock or partial blockage in the supply pipework.	Flush through pipework to ensure removal of debris and any airlocks.
	Partial blockage in the outlet	Remove to Clean and soak in suitable solution.
No hot water or cycling hot and cold	Instantaneous water heater cycles on and off as flow rate or pressure is too low.	Increase water flow rate or pressure through system.
No Flow	Closed isolation valve.	Open isolation valve.
	Mains water supply turned off.	Turn on mains water supply.
Temperatures not corresponding with taps	Inlet pipes have been connected incorrectly	Swap the inlet tails around.

Our Guarantee

At Bristan, we want to make things as easy as possible for our customers. That's why we offer solid guarantees on all our products, effective from the date of purchase, to give you peace of mind.



Your guarantee starts from the purchase of your product, but you can still benefit from registering it for easier identification in the unlikely event of a manufacturing fault, please visit www.bristan.com/register

For any other queries, please call Customer Service on 0330 026 6273 where our expert team of advisors will be able to offer you any help and advice.

For full guarantee terms and conditions visit www.bristan.com/service-centre/guarantees

Contact Us

BRISTAN

Bristan Group Ltd.
A Masco Company

Part of **BRISTAN GROUP**

UK: Bristan Group,
Pooley Hall Drive,
Birch Coppice Business Park,
Dordon, Tamworth
B78 1SG.

EU: Masco Europe S.à.r.l.
14 Rue Strachen
6933 Mensdorf
Luxembourg

Email Us: enquire@bristan.com
Website: www.bristan.com
Call Us: +44330 026 6273