

AFTERCARE INSTRUCTIONS

Your fitting has a high quality finish and should be treated with care to preserve the visible surfaces. All surface finishes will wear if not cleaned correctly, the only safe way to clean your mixer is to wipe with a soft damp cloth. Stains can be removed using washing up liquid. All bath cleaning powders and liquids will damage the surface of your fitting, even non-scratch cleaners.

GUARANTEE

All products are manufactured to the highest standards and a 5 year guarantee covers any defect in manufacture.

NOTE: The 5 year guarantee on the valves is invalidated if damaged by any waterborne debris.

In the interests of continuous product development we reserve the right to alter specification as necessary.

PRODUCT CODE: QST ½ C, QST ¾ C, QST HNK C

TELEPHONE HELP LINE: 0844 701 6273

Bristan Group Ltd
Birch Coppice Business Park
Dordon
Tamworth
Staffordshire
B78 1SG
UK
A Masco Company

Web Site: www.bristan.com
Telephone: 0844 701 6274
Facsimile: 0844 701 6275
E-mail: enquire@bristan.com

(FI QST TAP) (Rev. D2)

(H)

Quest Basin, Bath & High Neck Taps

Fitting Instructions & Contents List

Please keep these instructions for future reference and for the ordering of spare parts.

WATER PRESSURE

These taps are suitable for use at all supply pressures. If installed at low pressure (tank fed), then the minimum distance from the outlet of the nozzle to the underside of the cold tank should be approximately 2 metres to ensure adequate performance.

The taps should be installed in compliance with Water Regulations. For further details contact your Local Water Authority.

CONTENTS

- | | |
|-------------------|------|
| 1. Tap Body | (x2) |
| 2. Backnut Washer | (x2) |
| 3. Backnut | (x2) |
| a. Valve | (x2) |
| b. Spline adaptor | (x2) |
| c. Screw | (x2) |
| d. Handle | (x2) |

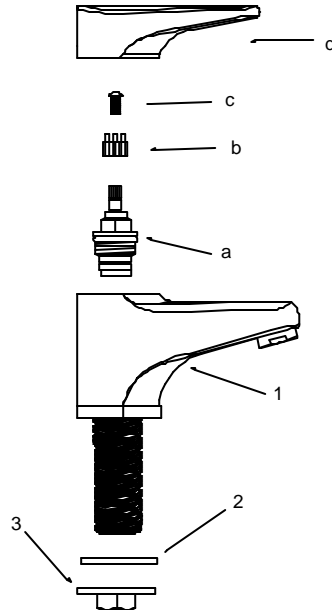

INSTALLATION

1. Identify all components and check for completeness, particularly before arranging fitting.
2. Install the taps (1) into the basin/bath. The backnut (3) and backnut washer (2) are used to secure the tap to the surfaces of basin/bath.
3. Connect the hot and cold water supplies.
4. Turn on the water supplies. Open both taps letting the water flow for a few minutes to check all joints and connections for leaks.
5. See over the page for aftercare instructions.

MAINTENANCE

If the fitting begins to drip:

1. Turn off the water supply.
2. Remove handles (d) by pulling off valve (a) and spline adaptor (b). Then remove screw (c) by unscrewing from valve (a).
3. Also remove spline adaptor (b) to avoid damaging it.
4. Using a suitable spanner, remove valve (a). Once removed, carefully clean seating, rubber washer and ceramic disc.
5. Replace all of the above then turn on the water supply.
6. If problem persists contact our helpline quoting the product code.

Please Note: In the unlikely event you find a part missing please contact our Customer Service Help line on 0870 4425553 or email enquire@bristan.com for immediate dispatch of part.

Check out our full range of Showers

Electric Showers

Digital Showers

Mixer Showers

Power Showers

Smart Showers

Shower Towers

From Top Shower Brands

Mira Showers

Aqualisa Showers

Triton Showers

Gainsborough Showers

Shower Pumps can upgrade your showering experience even more

Stuart Turner Shower Pumps

Salamander Shower Pumps

Grundfos Shower Pumps

plumbworld
Big brands, small prices.