

***mira***  
**eco**

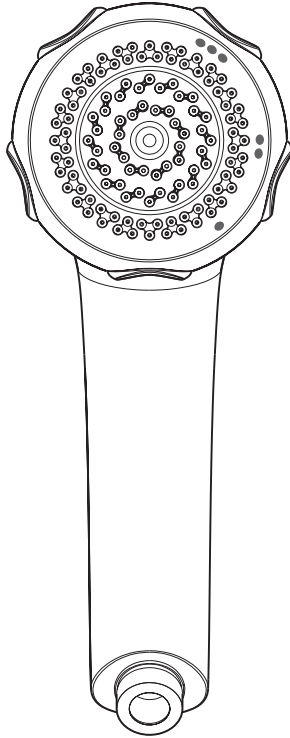

## ECO ADJUSTABLE HANDSET

1668.001 & 1668.002

Accessory Pack

Installation & User Guide

**These instructions are to be left with the user**

# INTRODUCTION

The Mira Eco adjustable shower handset has three different spray actions: start, soothe, and force. It is suitable for most high pressure mixer showers.

The Mira adjustable shower handset is available in white or chrome finish.

## System Applications

- Gravity-fed systems 0.5 bar and above
- Mains pressure systems
- Pumped systems
- Should not be used with electric showers

## Additional Features

- Save up to 75% water compared with Mira Logic at 0.5 bar pressure level
- Adjustable showerhead with three spray patterns, aerating across all three
- Visual indicators for spray settings
- Rub-clean rubber nozzles to remove scale build-up.
- Rubberised finger grips for easy adjustment.

## Operation

The Mira Eco functions by drawing air into the handset. Some noise will be noticeable to produce this aeration effect.

## Combi Boilers

When used in conjunction with an instantaneous water heater (combi boiler) in summer months, you may experience fluctuations in water temperature when additional draw offs of cold water are taken e.g. (taps or toilet flush).

## Pumped Systems

To get the greatest savings from Eco handset, we recommend the pump is run at the lowest flow setting.

## Design Registration

Design Registration	3 003 935
---------------------	-----------

## Water Saving

Water efficiency not only saves money but helps improve the environment and conserve the water we have. Heating water accounts for a lot of the energy used in homes, so the more water used, the more energy is needed, contributing to climate change.

Mira ECO Handset reduces the amount of water needed thanks to its aeration device and therefore uses less energy to heat the water.

Below are some key points which highlight more ways of being water and energy efficient:

- Any warm water which comes through the tap first before running cold can be collected and used to water plants
- Keep a jug of water in the fridge instead of waiting for the tap to run cold
- Turning off the taps when you are brushing your teeth or shaving can save up to five litres a minute
- Vegetables and fruit should be washed in a bowl rather than under a running tap
- Use the minimum amount of water required when you boil water in saucepans and kettles, saving energy as well as water
- Dripping taps can waste up to 4 litres of water a day. Replace worn tap washers for a quick and cheap way of saving water
- Always use the Mira Eco to ensure you save water and improve energy efficiency.

## **Mira Showers is supporting WaterAid's work in Madagascar**

Madagascar is a unique and beautiful country with a very rich culture, but it is also one of the poorest countries in the world and lack of access to water and sanitation pose a serious threat to health. Mira Showers is supporting WaterAid's work in the country.

Women and children often bear the burden of collecting water. This can take hours every day and is physically dangerous and tiring. Children often miss school because they have to collect water, or because they are ill from drinking unsafe water.

Mira is supporting WaterAid to tackle this situation through enabling communities in Madagascar to gain access to safe water and sanitation. These essential services have an impact far beyond the obvious positive effects on health. They underpin education and livelihoods and form the first step in overcoming poverty.

Mira has committed to raising a minimum of £10,000 for WaterAid through this initiative. So, by buying a Mira Eco handset, you are helping to enable more people to gain access to safe water and sanitation.

*£1 per product sold is paid to WaterAid Trading Limited which covenants all its taxable profits to WaterAid, registered charity number 288701. This promotion will raise a guaranteed £10,000 for WaterAid.*

For more information about WaterAid and the great work they do please go to: [www.wateraid.org](http://www.wateraid.org)



Charity Registration Number: 288701

# SPECIFICATION

## Specifications

Mira Eco should not be used on gravity fed systems under 0.5 bar pressure or electric showers.

Minimum maintained pressure: **50 kPa (0.5 bar)**.

Maximum maintained pressure: **500 kPa (5.0 bar)**.

**Warning!** Exceeding the stated maximum maintained pressure could result in excessive spray forces and possible damage to the product.

The graph below shows the water saving made using the ECO handset.

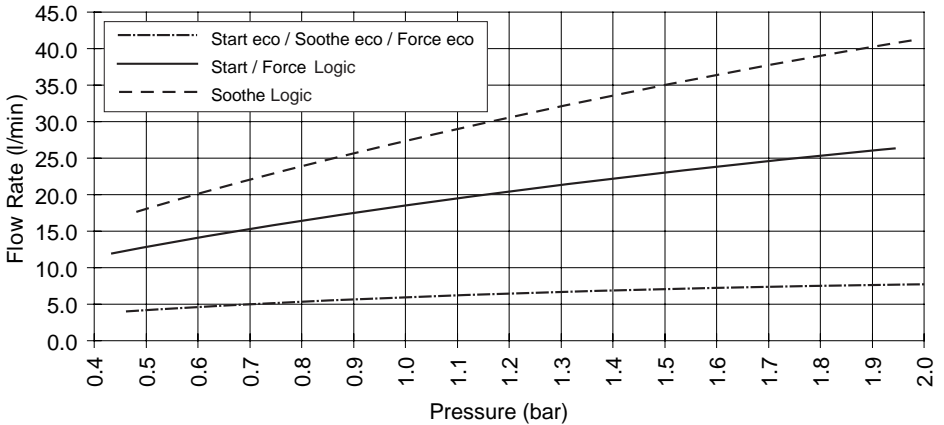

# OPERATION

## Spray Settings

The Mira Eco handset has three different spray modes, **Start**, **Soothe** and **Force**. All three modes aerate enabling water saving across all sprays. The handset operation is described below:

1. **Start:** Turn the spray plate anticlockwise until it 'clicks'. Water will flow from the outer set of holes.

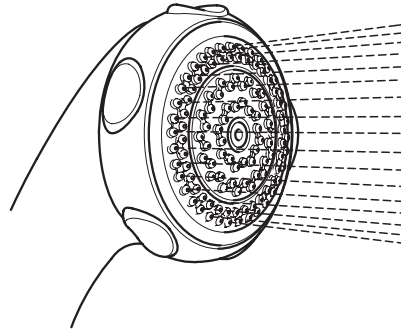

2. **Soothe:** Turn the spray plate anticlockwise until it 'clicks'. Water will flow from the large diameter holes.

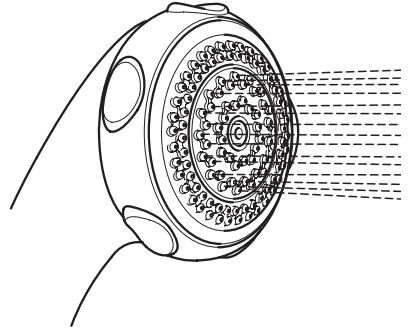

3. **Force:** Turn the spray plate anticlockwise until it 'clicks'. Water will flow from the inner set of holes.

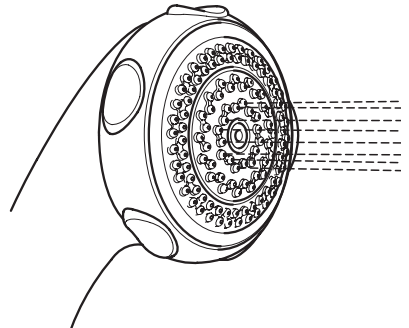

# MAINTENANCE

## Cleaning

Many household cleaners contain abrasives and chemical substances, and should not be used for cleaning plated or plastic fittings. These finishes should be cleaned with a mild washing up detergent or soap solution, and then wiped dry using a soft cloth.

1. To remove limescale, use your thumb or a soft cloth to wipe any limescale from the soft rubber nozzles and the front face of the showerhead.

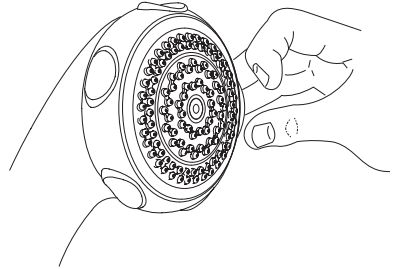

# SPARES

450.08 Service Pack 'O' Seals - components identified 'A'

450.13 Adjuster Ring - White

450.19 Adjuster Ring - Chrome

1668.001 ECO Handset - White

1668.002 ECO Handset - Chrome

1668.029 Spray Plate Pack - Chrome

1668.030 Spray Plate Pack - White

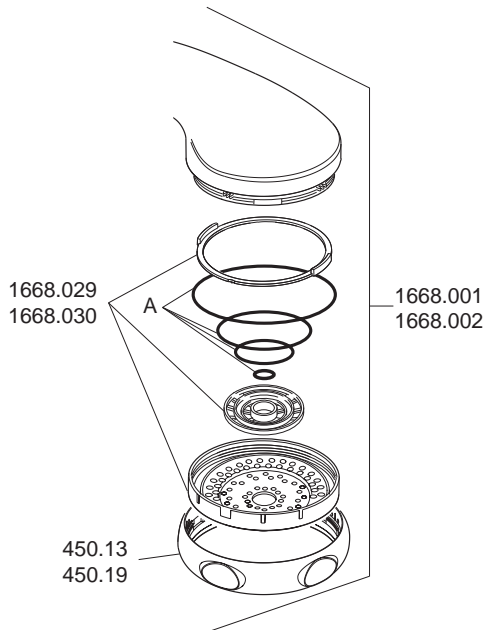

# CUSTOMER SERVICE

## Guarantee of Quality

Mira Showers guarantee your shower fittings against any defect in materials or workmanship for a period of one year from the date of purchase.

Alternatively, to confirm the applicable guarantee period please contact Customer Services.

To validate the guarantee, please return your completed registration card.

Within the guarantee period we will resolve defects, free of charge, by repairing or replacing parts or modules as we may choose.

To be free of charge, service work must only be undertaken by Mira Showers or our approved agents.

Service under this guarantee does not affect the expiry date.

The guarantee on any exchanged parts or product ends when the normal product guarantee period expires.

### **Not covered by this guarantee:**

Damage or defects arising from incorrect installation, improper use or lack of maintenance, including build-up of limescale.

Damage or defects if the product is taken apart, repaired or modified by any persons not authorised by Mira Showers or our approved agents.

This guarantee is in addition to your statutory and other legal rights.

## What to do if something goes wrong

If when you first use your shower, it doesn't function correctly, first contact your installer to check that installation and commissioning are satisfactory and in accordance with the instructions in this manual. We are on hand to offer you or your installer any advice you may need.

Should this not resolve the difficulty, simply contact our Customer Services Team who will give every assistance and, if necessary, arrange for our service engineer to visit. If the performance of your shower declines, consult this manual to see whether simple home maintenance is required. Please call our Customer Services Team to talk the difficulty through, request a service under guarantee if applicable, or take advantage of our comprehensive After-Sales service.

As part of our quality and training programme calls may be recorded or monitored.

Our Customer Services Team is comprehensively trained to provide every assistance you may need: help and advice, spare parts or a service visit.

## Spare Parts

We maintain an extensive stock of spares and aim to provide support throughout the product's expected life.

Spares can be purchased from approved stockists or merchants (locations on request) or direct from Customer Services.

Spares direct will normally be despatched within two working days. Payment can be made by Visa or MasterCard at the time of ordering. Should payment by cheque be preferred, a pro-forma invoice will be sent.

All spares are guaranteed for 12 months from date of purchase. Spares that have been supplied directly form us can be returned within one month from date of purchase, providing that they are in good order and the packaging is unopened.

**Note!** Returned spares will be subject to a 15% restocking charge and authorisation must be obtained before return. Please contact our Customer Services Team.

**Note!** In the interests of safety, spares requiring exposure to mains voltages can only be sent to competent persons.

## Service

Our Service Force is available to provide a quality service at a reasonable cost. You will have the assurance of a Mira trained engineer/agent, genuine Mira spare parts and a 12 month guarantee on the repair.

Payment should be made directly to the engineer/agent using Visa, MasterCard or a cheque supported by a banker's card.

## To Contact Us

**England, Scotland, Wales and Northern Ireland**

**Mira Showers Customer Services**

Telephone: 0870 241 0888, Mon to Fri 8:00 am - 5:30 pm  
Sat 8:30 am - 3:30 pm

E-mail: [technical@mirashowers.com](mailto:technical@mirashowers.com)

Fax: 01242 282595

By Post: Cromwell Road, Cheltenham,  
Gloucestershire, GL52 5EP

### **Eire**

**Modern Plant Ltd (Dublin)**

Telephone: 01 459 1344, Mon to Fri 9:00 am - 5:00 pm

E-mail: [sales@modernplant.ie](mailto:sales@modernplant.ie)

Fax: Dublin 01 459 2329

Post: Otter House, Naas Road,  
Clondalkin, Dublin 22

**Modern Plant (Cork)**

Telephone: 021 496 8755, Mon to Fri 9:00 am - 5:00 pm

E-mail: [cork@modernplant.ie](mailto:cork@modernplant.ie)

Fax: 021 496 8607

Post: Tramore Road, Cork

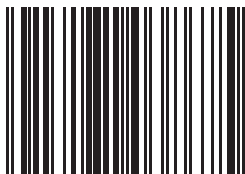

5 013181 038675 >

Mira is a registered trade mark of  
Kohler Mira Limited.

The company reserves the right to alter  
product specifications without notice.

[www.mirashowers.com](http://www.mirashowers.com)

**mira**  
SHOWERS



FM 14648



**plumbworld**  
**Big brands, small prices.**

Pdf Supplied By <http://www.plumbworld.co.uk/>