

IMPORTANT – CARE OF YOUR PRODUCT CLEANING

After use all surfaces should be maintained by wiping with a soft, damp, clean cloth and then polished using a dry duster. NO abrasive powder, detergents or polishes should be used. Cleaner containing alcohol, acid or corrosive chemicals should not be used.

NOTE

- ◆ Some household bleaches and denture cleaners can damage plated or coloured finishes and if splashed onto a fitting should be immediately washed off with cold water.
- ◆ If these instructions are followed this product will give many years of satisfactory use.
- ◆ We have a policy of continuous improvement and reserve the right to change specification without notice.

IMPORTANT:

In case of reduction of flow rate, close the two main inlets and check if the filter at the bottom of the non-return valve are dirty, **in this case clean them.**

GUARANTEE

The shower valve is guaranteed for a period of 2 years against any defects of materials and workmanship from date of purchase, subject to correct installation, maintenance and use in accordance with this instruction leaflet. Please retain proof of purchase.

During the guarantee period parts will be replaced or repaired at our option. No labour costs will be reimbursed without the prior agreement of Bathroom Brands International Ltd.

This guarantee is offered as an extra benefit and does not affect your statutory rights as a consumer in any way whatsoever. 10.'05



PARK LANE
traditional bathrooms



**CONCEALED THERMOSTATIC
SHOWER MIXER
PWD1239**

bathroom brands
INTERNATIONAL LTD
customerservice@bathroombrands.co.uk

GENERAL CHARACTERISTICS

In the case of instantaneous heaters, hot water flow has to at least meet the minimum flow rate required by the heater.

(Specified by heater manufacturer)

OPERATING SPECIFICATIONS

Hot water supply temperature:

Maximum: 85°C

Minimum: 5°C Higher than maximum required mixed temperature.

Recommended: 65°C.

Minimum difference between hot and mixed temperature is 10°C.

Operating Pressure

Maximum 5 Bar

Minimum 0.1 Bar

MAXIMUM PRESSURE DIFFERENTIAL RATIO 5:1

Operating pressure (on hot and cold line) should be kept as balanced as possible in order to assure maximum efficiency.

When the pressure is higher than a 5 Bar, a pressure reducing valve should be fitted to the incoming supply.

TECHNICAL DATA

This mixer is supplied with a cover plate which is chrome plated. The temperature control knob is graduated from 15°C to 60°C with auto stop at 38°C to avoid scalding.

The valve is provided with an additional tapping at base of the valve for bath filter spout. When using the bottom outlet a volume control is required. Fit a stop valve between valve outlet and delivery point.

PLUMBING RECOMMENDATIONS

- An independent water supply (both hot and cold) is recommended.
- Large runs of pipe work will cause frictional loss of pressure.
- The recommended supply from both cylinder and water tank should be 22 mm minimum reducing to 15 mm within half a metre of valve.
- If more than one shower valve is installed the minimum feed from tank and cylinder should be 28 mm, reducing to 15 mm within half a meter valve. (Ensure adequate supply of both hot and cold water can be maintained).
- In installations where a pump is required, install pump before shower mixer inlets.

WATER BYELAWS

The mixing valve should be installed in compliance with the water bye laws. For further details refer to the latest copy of water bye laws guide or your local water authority.

FITTING COVER PLATE

- Remove chrome control handles.
- Push chrome cover plate over temperature control valve.
- When in position adjust to maintain cover plate in position.
- Fit control handles and check operation.
- Check that temperature is at max. 43°C before shower is used.

CARTRIDGE CHANGE AND CLEANING

Through years of use, impurities and lime scale could restrict flow of water through the filters of the cartridge. To clean it:

- Shut off water supply to both inlets.
- Remove the temperature control handle.
- Unscrew cartridge using a spanner. Wash filters under running water or leave to soak in vinegar or de-scaling agent.
- Before re-assembling cartridge clean its housing with wet cloth and grease "O"rings on cartridge. WRAS approved grease should be used.
- Re-assembling cartridge into body.
- Re-fit temperature handle taking care to ensure correct alignment.

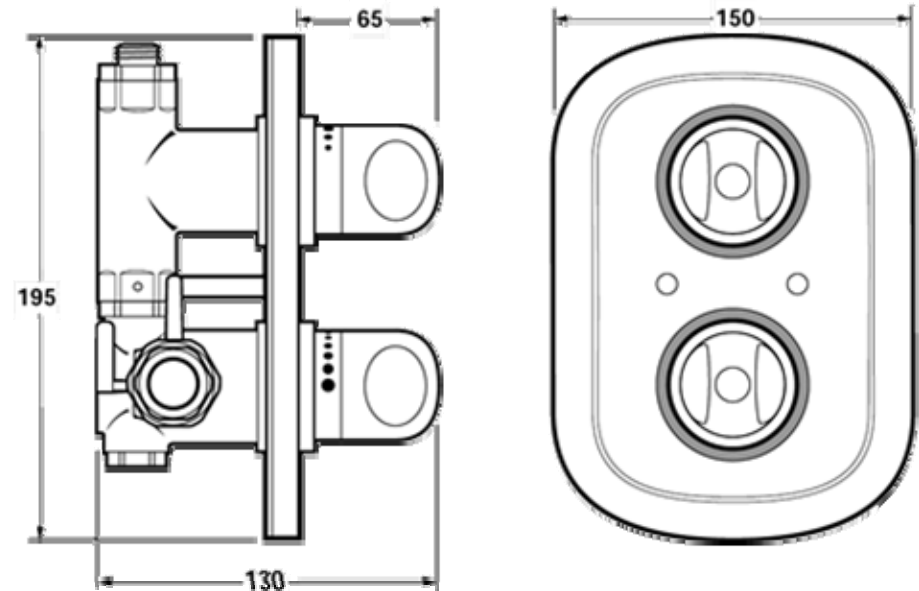

plumbworld
Big brands, small prices.

Pdf Supplied By <http://www.plumbworld.co.uk/>